

SG-5110

MULTI-SERVICE SECURITY GATEWAY

Quick Start Guide **V1.0**

Introduction

Thank you for choosing SG-5110 security gateway. This guide is designed to familiarize you with the layout of the gateway and describes how to deploy the gateway in your network.

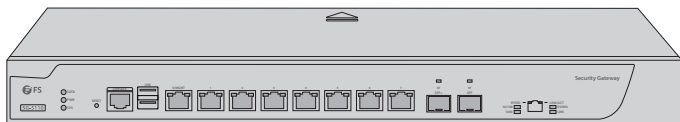

SG-5110

Accessories



Power Cord x1



Console Cable x1

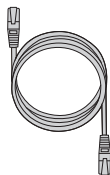

Network Cable x1



Rubber Pad x4



Mounting Bracket x2



M4 Screw x6

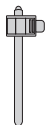

Power Cord Tie x1



NOTE: This gateway has dust plugs delivered with it. Keep the dust plugs properly and use them to protect idle optical ports.

Hardware Overview

Front Panel Ports

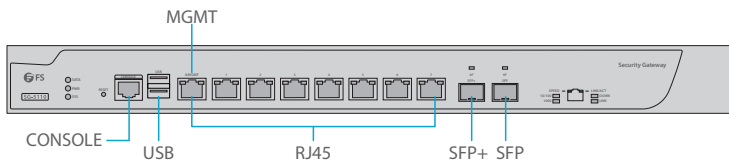

Ports	Description
RJ45	10/100/1000BASE-T ports for Ethernet connection
SFP	SFP port for 1G connection
SFP+	SFP+ port for 10G connection
CONSOLE	An RJ45 console port for serial management
MGMT	An Ethernet management port
USB	A USB management port for software and configuration backup and offline software upgrade

Front Panel Button

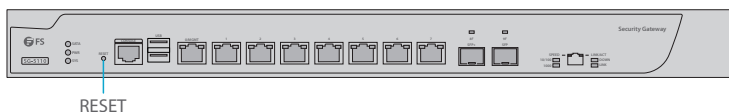

Button	Description
RESET	Press and release the RESET button to restart the device. To restore to factory default, press and hold the RESET button for more than three seconds.

Back Panel

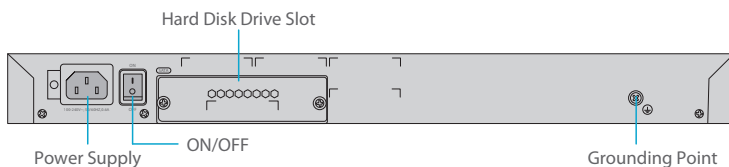

Back Panel Button

Button	Description
Power ON/OFF	Control the gateway power supply.

Front Panel LEDs

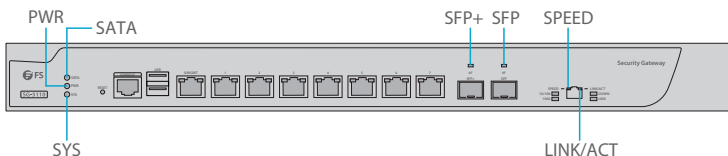

LEDs	Status	Description
PWR	Off	The power module is not in the position or fails.
	Solid Green	The power module is working properly.
SYS	Blinking Green	The system is being initialized.
	Solid Green	The initialization process is complete.
	Solid Red	The system sends out an alarm.
SATA	Solid Green	The SATA disk is installed.
	Blinking Green	The SATA disk is reading or writing data.
LINK/ACT	Solid Green	The port is connected at 10/100/1000M.
	Blinking Green	The port is receiving or transmitting data.
SPEED	Off	The port is connected at 10/100M.
	Solid Orange	The port is connected at 1000M.
SFP+	Solid Green	The port is connected.
	Blinking Green	The port is receiving or transmitting data.
SFP	Solid Green	The port is connected.
	Blinking Green	The port is receiving or transmitting data.

Installation Requirements

Before you begin the installation, make sure that you have the following:

- Phillips screwdriver.

- Standard-sized, 19" wide rack with a minimum of 1U height available.
- Category 5e or higher RJ-45 Ethernet cables and fiber optical cables for connecting network devices.

Site Environment :

- Do not place the device in a damp or wet location. Do not let any liquid enter the chassis.
- Do not install the equipment in a dusty environment.
- Keep the device away from heat sources.
- Ensure the normal grounding of device.
- Wear an anti-static wrist strap to install and maintain the device.
- Use UPS (Uninterruptible Power Supply) to prevent power failure and other interferences.

Mounting the Gateway

Desk Mounting

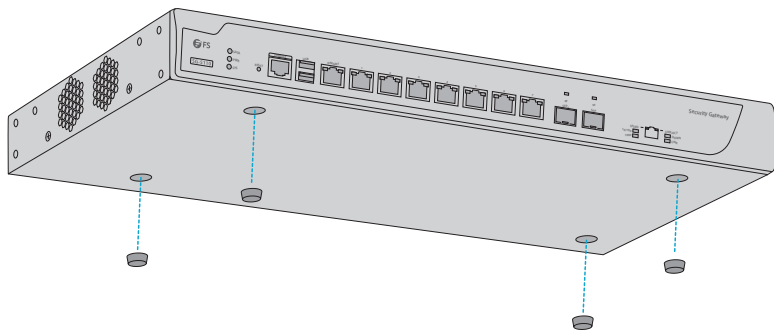

1. Attach four rubber pads to the bottom.
2. Place the chassis on a desk.

Rack Mounting

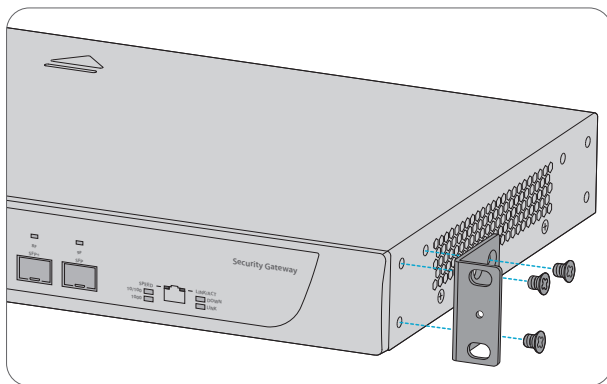

1. Secure the mounting brackets to the two sides of the gateway with six M4 screws.

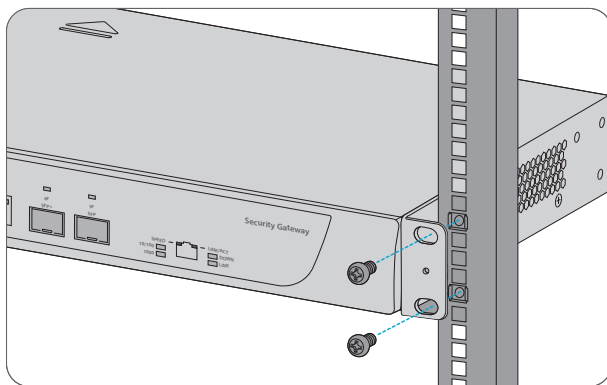

2. Attach the gateway to the rack using four M6 screws and cage nuts.

Grounding the Gateway

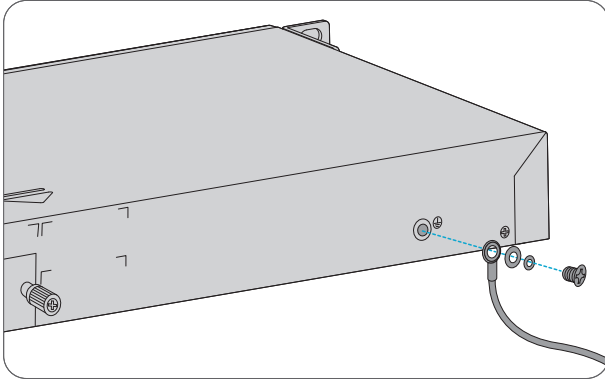

1. Connect one end of the grounding cable to a proper earth ground, such as the rack in which the gateway is mounted.
2. Secure the grounding lug to the grounding point on the gateway back panel with the washers and screws.

Connecting the Power

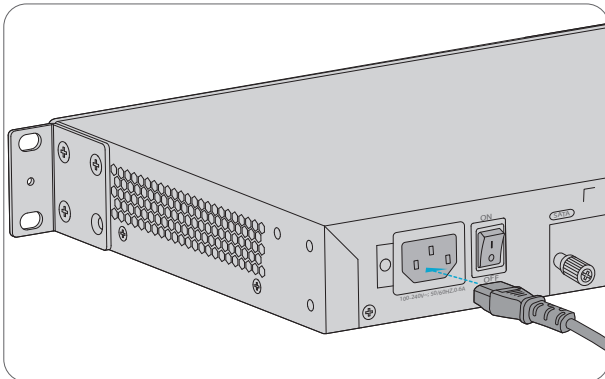

1. Plug the AC power cord into the power port on the back of the gateway.
2. Connect the other end of the power cord to an AC power source.



CAUTION: Do not install the power cord while the power is on, and when the power cord is connected, the fan will start to operate whether the power button is on or off.

Connecting the RJ45 Ports

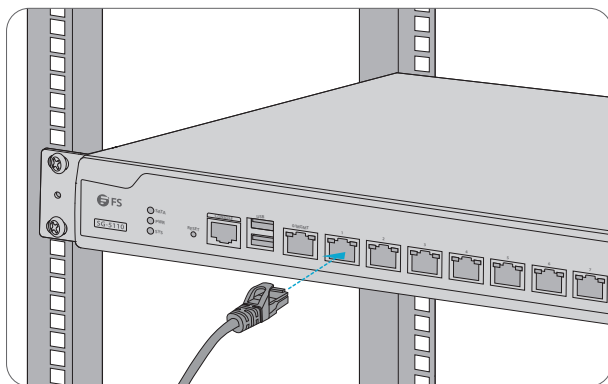

1. Connect an Ethernet cable to the RJ45 port of a computer or other network devices.
2. Connect the other end of the Ethernet cable to the RJ45 port of the gateway.

Connecting the SFP/SFP+ Ports

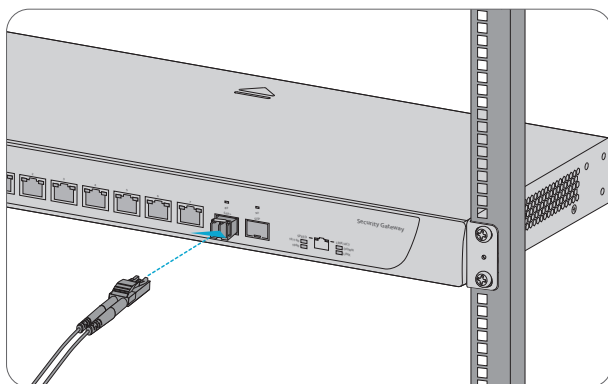

1. Plug the compatible SFP/SFP+ transceiver into the fiber port.
2. Connect a fiber optic cable to the fiber transceiver. Then connect the other end of the cable to another fiber device.



CAUTION: Laser beams will cause eye damage. Do not look into bores of optical modules or optical fibers without eye protection.

Connecting the Console Port

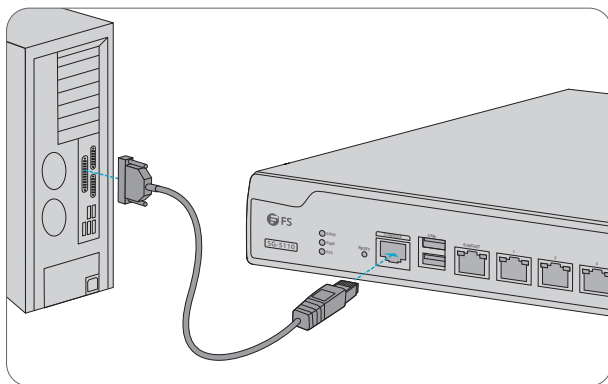

1. Insert the RJ45 connector into the RJ45 console port on the front of the gateway.
2. Connect the DB9 female connector of the console cable to RS-232 serial port on the computer.

Connecting the MGMT Port

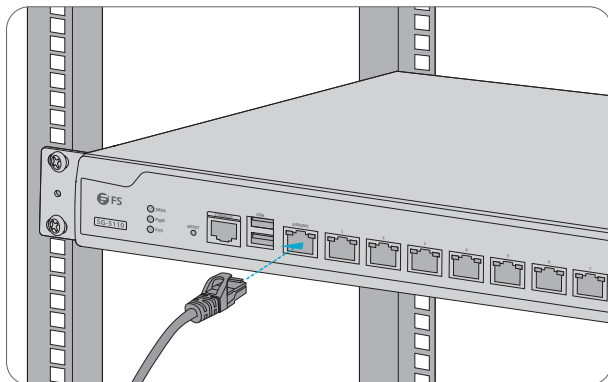

1. Connect one end of a standard RJ45 Ethernet cable to a computer.
2. Connect the other end of the cable to the MGMT port on the front of the gateway.

Configuring the Gateway

Configuring the Gateway Using the Web-based Interface

Step 1: Connect the computer to the Management port of the gateway using the network cable.

Step 2: Set the IP address of the computer to **192.168.1.x**. ("x" is any number from 2 to 254.)

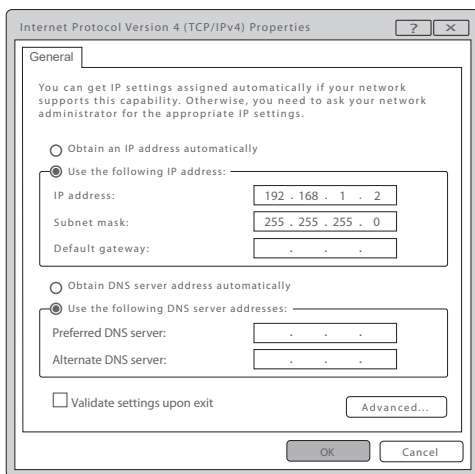

Step 3: Open a browser, type **http://192.168.1.1**, and enter the default username and password, **admin/admin**.



Step 4: Click **Log In** to display the web-based configuration page. You are then required to enter and configure a new password for the account the first time you log in.

Configuring the Gateway Using the Console Port

Step 1: Connect a computer to the gateway's console port using the supplied console cable.

Step 2: Start the terminal simulation software such as HyperTerminal on the computer.

Step 3: Set the parameters of the HyperTerminal: 9600 bits per second, 8 data bits, no parity, 1 stop bit and no flow control.

Quick Connect

Protocol: Serial

The port may be manually entered or selected from the list.

Port: COM3

Baud rate: 9600

Data bits: 8

Parity: None

Stop bits: 1

Name of pipe:

Flow Control

DTR/DSR

RTS/CTS

XON/XOFF

Show quick connect on startup

Save session

Open in a tab

Connect Cancel

Step 4: After setting the parameters, click **Connect** to enter.



NOTE: If you perform remote access via SSH and Telnet, the admin password should have already been changed since the simple password is potential security hazards.

Troubleshooting

Power System Fault

According to the power indicator on the front panel, the gateway can be used to determine whether the power supply system of the gateway is faulty. If the power supply system is working normally, the power indicator should remain lit. If the power indicator light is unlit, please check the following:

1. Whether the power switch is turned on.
2. Whether the gateway power cable is connected correctly.
3. Whether the cabinet power sockets are loosely connected to power modules.



WARNING: Do not plug or pull the power cable when the power switch is already turned on.

Configuration System Troubleshooting

The console configuration terminal shows system booting message when the device is powered on. If the configuration system has failed, it displays error information or nothing at all. If the configuration terminal shows no information, please check the following:

1. Make sure the power supply is correctly connected and powered on.
2. Verify the Console cable is connected properly.
3. Ensure the terminal configuration settings are correct.

Troubleshooting for Terminal Show Error Codes

If the configuration terminal shows error codes, it is likely that the terminal (such as HyperTerminal) parameters are set incorrectly. Please confirm the parameters of the terminal (such as HyperTerminal).

Support and Other Resources

- Download <https://www.fs.com/download.html>
- Help Center https://www.fs.com/service/help_center.html
- Contact Us https://www.fs.com/contact_us.html

Product Warranty

FS ensures our customers that any damage or faulty items due to our workmanship, we will offer a free return within 30 Days from the day you receive your goods. This excludes any custom made items or tailored solutions.



Warranty: The gateway enjoys 3 years limited warranty against defect in materials or workmanship. For more details about warranty, please check at <https://www.fs.com/policies/warranty.html>



Return: If you want to return item(s), information on how to return can be found at https://www.fs.com/policies/day_return_policy.html

Q.C. PASSED