

FiberstoreOS

Multicast Configuration Guide

Contents

1 Configuring IP Multicast-Routing.....	1
1.1 Overview.....	1
1.2 Configuration.....	1
1.3 Validation.....	1
2 Configuring IGMP.....	3
2.1 Overview.....	3
2.2 References.....	4
2.3 Configuration.....	4
2.4 Validation.....	6
3 Configuring PIM.....	7
3.1 Overview.....	7
3.2 References.....	7
3.3 Terminology.....	7
3.4 Configuring General PIM Sparse-mode.....	11
3.4.1 Topology.....	11
3.4.2 Configuration.....	11
3.4.3 Validation.....	13
3.5 Configuring RP dynamically.....	14
3.5.1 Configuration.....	15
3.5.2 Validation.....	16
3.6 Configuring Bootstrap Router.....	17
3.6.1 Topology.....	18
3.6.2 Configuration.....	18
3.6.3 Validation.....	18
3.7 Configuring PIM-SSM feature.....	19
4 Configuring IGMP Snooping.....	21
4.1 Overview.....	21
4.2 Enable Globally Or Per Vlan.....	21
4.2.1 Configuration.....	21
4.2.2 Validation.....	22
4.3 Configuring Fast Leave.....	22
4.3.1 Configuration.....	22
4.3.2 Validation.....	23
4.4 Configuring Querier Parameters.....	23

4.4.1 Configuration.....	23
4.4.2 Validation.....	24
4.5 Configuring Mrouter Port.....	24
4.5.1 Configuration.....	24
4.5.2 Validation.....	25
4.6 Configuring Querier Tcn.....	25
4.6.1 Configuration.....	25
4.6.2 Validation.....	26
4.7 Configuring Report Suppression.....	26
4.7.1 Configuration.....	26
4.7.2 Validation.....	26
4.8 Configuring Static group.....	27
4.8.1 Configuration.....	27
4.8.2 Validation.....	27
4.9 Limitations And Configuration Guidelines.....	27
5 Configuring MVR.....	29
5.1 Overview.....	29
5.2 Terminology.....	29
5.3 Topology.....	30
5.4 Configurations.....	30
5.5 Validation.....	32

Figures

Figure 3-1 Configuring RP statically.....	11
Figure 3-2 BSR Topology.....	18
Figure 5-1 MVR Topology.....	30

1 Configuring IP Multicast-Routing

1.1 Overview

Multicast protocols allow a group or channel to be accessed over different networks by multiple stations (clients) for the receipt and transmit of multicast data.

Distribution of stock quotes, video transmissions such as news services and remote classrooms, and video conferencing are all examples of applications that use multicast routing.

- Internet Group Management Protocol (IGMP) is used among hosts on a LAN and the routers (and multilayer switches) on that LAN to track the multicast groups of which hosts are members.
- Protocol-Independent Multicast (PIM) protocol is used among routers and multilayer switches to track which multicast packets to forward to each other and to their directly connected LANs. PIM has two modes: Sparse-mode and Dense-mode. Currently, we only support Sparse-mode

1.2 Configuration

The Max allowed IP Multicast Route number can be configured. By default, 2048 IP multicast routes are supported.

Switch# configure terminal	Enter Configuration mode
Switch(config)# ip multicast route-limit 1000	Configuring max allowed ip multicast route

1.3 Validation

```
Switch# show ip mroute 192.168.47.2
IP Multicast Routing Table
Flags: I - Immediate Stat, T - Timed Stat, F - Forwarder installed
Timers: Uptime/Stat Expiry
Interface State: Interface (TTL)

(192.168.47.2, 238.255.0.1), uptime 00:00:03, stat expires 00:03:27
Owner PIM-SM, Flags: TF
Incoming interface: eth-0-3
```

```
Outgoing interface list:
  Register (1)
  eth-0-1 (1)

(192.168.47.2, 238.255.0.2), uptime 00:00:02, stat expires 00:03:28
Owner PIM-SM, Flags: TF
  Incoming interface: eth-0-3
  Outgoing interface list:
    Register (1)
eth-0-2 (1)
```

2 Configuring IGMP

2.1 Overview

To participate in IP multicasting, multicast hosts, routers, and multilayer switches must have the IGMP operating. This protocol defines the querier and host roles:

- A querier is a network device that sends query messages to discover which network devices are members of a given multicast group.
- A host is a receiver that sends report messages (in response to query messages) to inform a querier of a host membership.

A set of queries and hosts that receive multicast data streams from the same source is called a multicast group. Queriers and hosts use IGMP messages to join and leave multicast groups.

Any host, regardless of whether it is a member of a group, can send to a group. However, only the members of a group receive the message. Membership in a multicast group is dynamic; hosts can join and leave at any time. There is no restriction on the location or number of members in a multicast group.

A host can be a member of more than one multicast group at a time. How active a multicast group is and what members it has can vary from group to group and from time to time. A multicast group can be active for a long time, or it can be very short-lived. Membership in a group can constantly change. A group that has members can have no activity.

IGMP packets are sent using these IP multicast group addresses:

- IGMP general queries are destined to the address 224.0.0.1 (all systems on a subnet).
- IGMP group-specific queries are destined to the group IP address for which the switch is querying.
- IGMP group membership reports are destined to the group IP address for which the switch is reporting.
- IGMP Version 2 (IGMPv2) leave messages are destined to the address 224.0.0.2 (all-multicast-routers on a subnet). In some old host IP stacks, leave messages might be destined to the group IP address rather than to the all-routers address.

2.2 References

The IGMP module is based on the following RFC

- RFC 1112
- RFC 2236
- RFC 3376

2.3 Configuration

There is no explicit command to enable IGMP, which is always combined with PIM-SM. When PIM-SM is enabled on an interface, IGMP will be enabled automatically on this interface, vice versa. But notice, before IGMP can work, IP Multicast-routing must be enabled globally firstly. We support build IGMP group record by learning IGMP packets or configuring static IGMP group by administer.

Enable IGMP

Switch# configure terminal	Enter Configuration mode
Switch(config)# ip multicast-routing	Enable IP Multicast routing globally
Switch(config)# interface eth-0-1	Enter interface eth-0-1
Switch(config-if)# no switchport	Change eth-0-1 as routed port
Switch(config-if)# ip address 10.10.10.10/24	Set the interface IP address
Switch(config-if)# ip pim sparse-mode	Enable ip pim sparse mode & enable igmp

Configuring IGMP Interface Parameters

Switch# configure terminal	Enter Configuration mode
Switch(config)# interface eth-0-1	Enter interface eth-0-1
Switch(config-if)# ip igmp version 2	Set igmp version
Switch(config-if)# ip igmp query-interval 120	Set igmp query interval
Switch(config-if)# ip igmp query-max-response-time 12	Set igmp query max response time
Switch(config-if)# ip igmp robustness-variable 3	Set igmp robustness value
Switch(config-if)# ip igmp last-member-query-count 3	Set igmp last member query count
Switch(config-if)# ip igmp last-member-query-interval 2000	Set igmp last member query interval

Limit Max IGMP Group Number

The limit can be configured globally or per interface.

Switch# configure terminal	Enter Configuration mode
Switch(config)# ip igmp limit 2000	Set global max igmp group number
Switch(config)# interface eth-0-1	Enter interface eth-0-1
Switch(config-if)# ip igmp limit 1000	Set per-interface max igmp group number

Configuring Static IGMP Group

The static IGMP Group can be configured on interface.

Switch# configure terminal	Enter Configuration mode
Switch(config)# interface eth-0-1	Enter interface eth-0-1
Switch(config-if)# ip igmp static-group 228.1.1.1	Configure static igmp group on interface eth-0-1

Configuring SSM Mapping

Switch# configure terminal	Enter Configuration mode
Switch(config)# ip igmp ssm-map enable	Enable ssm mapping globally
Switch(config-if)# ip igmp ssm-map ipacl 192.168.1.1	Configure group in access list ipacl to map to 192.168.1.1 when switch receives igmpv1/v2 report

Configuring Multicast Proxy Downstream And Upstream

Switch# configure terminal	Enter Configuration mode
Switch(config)# interface eth-0-1	Enter interface eth-0-1
Switch(config-if)# no switchport	Change the interface as routed port
Switch(config-if)# ip pim sparse-mode	Enable PIM sparse-mode
Switch(config-if)# ip igmp proxy-service	Set eth-0-1 as igmp proxy upstream
Switch(config)# interface eth-0-2	Enter interface eth-0-2
Switch(config-if)# no switchport	Change the interface as routed port
Switch(config-if)# ip pim sparse-mode	Enable PIM sparse-mode
Switch(config-if)# ip igmp mroute-proxy eth-0-1	Set eth-0-2 as igmp proxy downstream, And its upstream is interface eth-0-1

2.4 Validation

Displaying IGMP Interface

```
Switch# show ip igmp interface
Interface eth-0-1 (Index 1)
  IGMP Inactive, Version 2 (default) proxy-service
  IGMP host version 2
  IGMP global limit is 2000
  IGMP global limit states count is currently 0
  IGMP interface limit is 1000
  IGMP interface has 0 group-record states
  IGMP activity: 0 joins, 0 leaves
  IGMP query interval is 120 seconds
  IGMP querier timeout is 366 seconds
  IGMP max query response time is 12 seconds
  Last member query response interval is 2000 milliseconds
  Group Membership interval is 372 seconds
  Last member query count is 3
  Robustness Variable is 3
Interface eth-0-2 (Index 2)
  IGMP Inactive, Version 2 (default)
  IGMP mroute-proxy interface is eth-0-1
  IGMP global limit is 2000
  IGMP global limit states count is currently 0
  IGMP interface limit is 16384
  IGMP interface has 0 group-record states
  IGMP activity: 0 joins, 0 leaves
  IGMP query interval is 125 seconds
  IGMP querier timeout is 255 seconds
  IGMP max query response time is 10 seconds
  Last member query response interval is 1000 milliseconds
  Group Membership interval is 260 seconds
  Last member query count is 2
  Robustness Variable is 2
```

Displaying IGMP group

```
Switch# show ip igmp groups
IGMP Connected Group Membership
Group Address      Interface      Uptime    Expires    Last Reporter
228.1.1.1          eth-0-1       00:00:05 stopped -
```

3 **Configuring PIM**

3.1 Overview

The Protocol Independent Multicasting-Sparse Mode (PIM-SM) is a multicast routing protocol designed to operate efficiently across Wide Area Networks (WANs) with sparsely distributed groups. It helps network nodes that are geographically dispersed to conserve bandwidth, and reduces traffic by simultaneously delivering a single stream of information to multiple locations.

PIM-SM uses the IP multicast model of receiver-initiated membership, supporting both shared and shortest-path trees, and uses soft-state mechanisms to adapt to changing network conditions. It relies on a topology-gathering protocol to populate a multicast routing table with routes.

3.2 References

The PIM-SM module is based on the following IETF standard:

RFC 4601

3.3 Terminology

Following is a brief description of terms and concepts used to describe the PIM-SM protocol:

Rendezvous Point (RP)

A Rendezvous Point (RP) router is configured as the root of the non-source-specific distribution tree for a multicast group. Join messages from receivers for a group are sent towards the RP. Data from senders is sent to the RP so that receivers can discover who the senders are, and receive traffic destined for the group.

Multicast Routing Information Base (MRIB)

The MRIB is a multicast topology table derived from the unicast routing table. In PIM-SM, the MRIB is used to decide where to send Join/Prune messages. It also provides routing metrics for destination addresses. These metrics are used when sending and processing Assert messages.

Reverse Path Forwarding

Reverse Path Forwarding (RPF) is a concept of an optimized form of flooding, where the router accepts a packet from SourceA through Interface IF1 only if IF1 is the interface the router would use in order to reach SourceA. It determines whether the interface is correct by consulting its unicast routing tables. The packet that arrives through interface IF1 is forwarded because the routing table lists this interface as the shortest path to the network. The router's unicast routing table determines the shortest path for the multicast packets. Because a router accepts a packet from only one neighbor, it floods the packet only once, meaning that (assuming point-to-point links) each packet is transmitted over each link once in each direction.

Tree Information Base (TIB)

The TIB is the collection of state at a PIM router storing the state of all multicast distribution trees at that router. It is created by receiving Join/Prune messages, Assert messages, and IGMP information from local hosts.

Upstream

Towards to root of the tree. The root of the tree might be either the Source or the RP.

Downstream

Away from the root of the tree. The root of tree might be either the Source or the RP.

Source-Based Trees

In the Source-Based Trees concept, the forwarding paths are based on the shortest unicast path to the source. If the unicast routing metric is hop counts, the branches of the multicast Source-Based Trees are minimum hop. If the metric is delay, the branches are minimum delay.

For every multicast source, there is a corresponding multicast tree that directly connects the source to all receivers. All traffic to the members of an associated group passes along the tree made for their source. Source-Based Trees have two entries with a list of outgoing interfaces-- the source address and the multicast group.

Shared Trees

Shared trees or RP trees (RPT) rely on a central router called the Rendezvous Point (RP) that receives all traffic from the sources, and forwards that traffic to the receivers. All hosts might not be receivers. There is a single tree for each multicast group, regardless of the number of sources. Only the routers on the tree know about the group, and information is sent only to interested receivers. With an RP, receivers have a place to join, even if no source exists.

The shared tree is unidirectional, and information flows only from the RP to the receivers. If a host other than the RP has to send data on the tree, the data must first be tunneled to the RP, and then multicast to the members. This means that even if a receiver is also a source, it can only use the tree to receive packets from the RP, and not to send packets to the RP (unless the source is located between the RP and the receivers).

Bootstrap Router (BSR)

When a new multicast sender starts sending data packets, or a new receiver starts sending the Join message towards the RP for that multicast group, it needs to know the next-hop router towards the RP. The BSR provides group-to-RP mapping information to all the PIM routers in a domain, allowing them to map to the correct RP address.

Sending out Hello Messages

PIM routers periodically send Hello messages to discover neighboring PIM routers. Hello messages are multicast using the address 224.0.0.13 (ALL-PIM-ROUTERS group). Routers do not send any acknowledgement that a Hello message was received. A hold time value determines the length of time for which the information is valid. In PIM-SM, a downstream receiver must join a group before traffic is forwarded on the interface.

Electing a Designated Router

In a multi-access network with multiple routers connected, one of them is selected to act as a designated router (DR) for a given period of time. The DR is responsible for sending Join/Prune messages to the RP for local members.

Determining the RP

PIM-SM uses a Bootstrap Router (BSR) to originate Bootstrap messages, and to disseminate RP information. The messages are multicast to the group on each link. If the BSR is not apparent, the routers flood the domain with advertisements. The router with the highest priority (if priorities are

same, the higher IP address applies) is selected to be the RP. Routers receive and store Bootstrap messages originated by the BSR. When a DR gets a membership indication from IGMP for (or a data packet from) a directly connected host, for a group for which it has no entry, the DR maps the group address to one of the candidate RPs that can service that group. The DR then sends a Join/Prune message towards that RP.

In a small domain, the RP can also be configured statically.

Joining the Shared Tree

To join a multicast group, a host sends an IGMP message to its upstream router, after which the router can accept multicast traffic for that group. The router sends a Join message to its upstream PIM neighbor in the direction of the RP. When a router receives a Join message from a downstream router, it checks to see if a state exists for the group in its multicast routing table. If a state already exists, the Join message has reached the shared tree, and the interface from which the message was received is entered in the Outgoing Interface list. If no state exists, an entry is created, the interface is entered in the Outgoing Interface list, and the Join message is again sent towards the RP.

Registering with the RP

A DR can begin receiving traffic from a source without having a Source or a Group state for that source. In this case, the DR has no information on how to get multicast traffic to the RP through a tree. When the source DR receives the initial multicast packet, it encapsulates it in a Register message, and unicasts it to the RP for that group. The RP deencapsulates each Register message, and forwards the extracted data packet to downstream members on the RPT.

Once the path is established from the source to the RP, the DR begins sending traffic to the RP as standard IP multicast packets, as well as encapsulated within Register messages. The RP temporarily receives packets twice.

When the RP detects the normal multicast packets, it sends a Register-Stop message to the source DR, meaning it should stop sending register packets.

Sending Register-Stop Messages

When the RP begins receiving traffic from the source, both as Register messages and as unencapsulated IP packets, it sends a Register-Stop message to the DR. This notifies the DR that the traffic is now being received as standard IP multicast packets on the SPT. When the DR receives this message, it stops encapsulating traffic in Register messages.

Pruning the Interface

Routers attached to receivers send Prune messages to the RP to disassociate the source from the RP. When an RP receives a Prune message, it no longer forwards traffic from the source indicated in the Prune message. If all members of a multicast group are pruned, the IGMP state of the DR is deleted, and the interface is removed from the Source and Group lists of the group.

Forwarding Multicast Packets

PIM-SM routers forward multicast traffic onto all interfaces that lead to receivers that have explicitly joined a multicast group. Messages are sent to a group address in the local subnetwork, and have a Time to Live (TTL) of 1. The router performs an RPF check, and forwards the packet. Traffic that arrives on the correct interface is sent onto all outgoing interfaces that lead to downstream receivers if the downstream router has sent a join to this router, or is a member of this group.

3.4 Configuring General PIM Sparse-mode

3.4.1 Topology

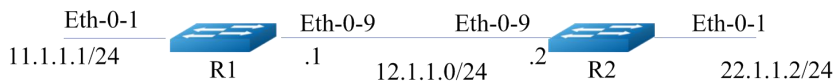

Figure 3-1 Configuring RP statically

3.4.2 Configuration

PIM-SM is a soft-state protocol. The main requirement is to enable PIM-SM on desired interfaces, and configure the RP information correctly, through static or dynamic methods. All multicast group states are maintained dynamically as the result of IGMP Report/Leave and PIM Join/Prune messages. Currently, we support only one RP for all multicast groups (224.0.0.0/4).

This section provides PIM-SM configuration examples for two relevant scenarios. The following graphic displays the network topology used in these examples:

In this example, using the above topology, R1 is the Rendezvous Point (RP), and all routers are statically configured with RP information. While configuring the RP, make sure that:

- Every router includes the ip pim rp-address 11.1.1.1 statement, even if it does not have any source or group member attached to it.
- There is only one RP address for a group scope in the PIM domain.
- All interfaces running PIM-SM must have sparse-mode enabled.

Here is a sample configuration:

Configuring R1

Switch# configure terminal	Enter the configure mode
Switch(config)# interface eth-0-1	Specify the interface (eth-0-1) to be configured and enter the Interface mode
Switch(config-if)# no shutdown	Turn up the interface
Switch(config-if)# no switchport	Change this port to Layer3 interface
Switch(config-if)# ip address 11.1.1.1/24	Configure IP address for this interface
Switch(config-if)# ip pim sparse-mode	Enable ip pim sparse mode
Switch(config-if)# exit	Exit the Interface mode and enter the Configure mode
Switch(config)# interface eth-0-9	Specify the interface (eth-0-9) to be configured and enter the Interface mode
Switch(config-if)# no shutdown	Turn up the interface
Switch(config-if)# no switchport	Change this port to Layer3 interface
Switch(config-if)# ip address 12.1.1.1/24	Configure IP address for this interface
Switch(config-if)# ip pim sparse-mode	Enable ip pim sparse mode
Switch(config-if)# exit	Exit the Interface mode and enter the Configure mode
Switch(config)# ip route 22.1.1.0/24 12.1.1.2	Configure a static route
Switch(config)# ip pim rp-address 11.1.1.1	Configure the static rp address

Configuring R2

Switch# configure terminal	Enter the configure mode
Switch(config)# interface eth-0-1	Specify the interface (eth-0-1) to be configured and enter the Interface mode
Switch(config-if)# no shutdown	Turn up the interface
Switch(config-if)# no switchport	Change this port to Layer3 interface
Switch(config-if)# ip address 22.1.1.2/24	Configure IP address for this interface
Switch(config-if)# ip pim sparse-mode	Enable ip pim sparse mode
Switch(config-if)# exit	Exit the Interface mode and enter the Configure mode

Switch(config)# interface eth-0-9	Specify the interface (eth-0-9) to be configured and enter the Interface mode
Switch(config-if)# no shutdown	Turn up the interface
Switch(config-if)# no switchport	Change this port to Layer3 interface
Switch(config-if)# ip address 12.1.1.2/24	Configure IP address for this interface
Switch(config-if)# ip pim sparse-mode	Enable ip pim sparse mode
Switch(config-if)# exit	Exit the Interface mode and enter the Configure mode
Switch(config)# ip route 11.1.1.0/24 12.1.1.1	Configure a static route
Switch(config)# ip pim rp-address 11.1.1.1	Configure the static rp address

3.4.3 Validation

Configure all the routers with the same ip pim rp-address 11.1.1.1 command as shown above. Use the following commands to verify the RP configuration, interface details, and the multicast routing table.

RP Details

At R1, the show ip pim sparse-mode rp mapping command shows that 11.1.1.1 is the RP for all multicast groups 224.0.0.0/4, and is statically configured. All other routers will have a similar output.

```
R1# show ip pim sparse-mode rp mapping
PIM group-to-RP mappings
Group(s): 224.0.0.0/4, Static
  RP: 11.1.1.1
      Uptime: 00:08:21
```

Interface Details

The show ip pim sparse-mode interface command displays the interface details for R1.

```
R1# show ip pim sparse-mode interface
Address          Interface VIFindex Ver/   Nbr   DR   DR       HoldTime
                  Mode    Count  Prior
11.1.1.1         eth-0-1  2      v2/S   0     1   11.1.1.1  105
12.1.1.1         eth-0-9  0      v2/S   1     1   12.1.1.2  105
```

IP Multicast Routing Table

The show ip pim sparse-mode mroute detail command displays the IP multicast routing table.

```
R1# show ip pim sparse-mode mroute detail
IP Multicast Routing Table

(*,*,RP) Entries: 0
```

```
(* ,G) Entries: 1
(S,G) Entries: 0
(S,G,rpt) Entries: 0
FCR Entries: 0

(*, 224.1.1.1) Uptime: 00:01:32
RP: 11.1.1.1, RPF nbr: None, RPF idx: None
Upstream:
  State: JOINED, SPT Switch: Enabled, JT: off
  Macro state: Join Desired,
Downstream:
  eth-0-9:
    State: JOINED, ET Expiry: 179 secs, PPT: off
    Assert State: NO INFO, AT: off
    Winner: 0.0.0.0, Metric: 4294967295, Pref: 4294967295, RPT bit: on
    Macro state: Could Assert, Assert Track
Join Olist:
  eth-0-9
```

```
R2# show ip pim sparse-mode mroute detail
IP Multicast Routing Table

(* ,*,RP) Entries: 0
(* ,G) Entries: 1
(S,G) Entries: 0
(S,G,rpt) Entries: 0
FCR Entries: 0

(*, 224.1.1.1) Uptime: 00:00:43
RP: 11.1.1.1, RPF nbr: 12.1.1.1, RPF idx: eth-0-9
Upstream:
  State: JOINED, SPT Switch: Enabled, JT Expiry: 18 secs
  Macro state: Join Desired,
Downstream:
  eth-0-1:
    State: NO INFO, ET: off, PPT: off
    Assert State: NO INFO, AT: off
    Winner: 0.0.0.0, Metric: 4294967295, Pref: 4294967295, RPT bit: on
    Macro state: Could Assert, Assert Track
Local Olist:
  eth-0-1
```

3.5 Configuring RP dynamically

A static configuration of RP works for a small, stable PIM domain; however, it is not practical for a large and not-suitable internet work. In such a network, if the RP fails, the network administrator might have to change the static configurations on all PIM routers. Another reason for choosing dynamic configuration is a higher routing traffic leading to a change in the RP.

We use the BSR mechanism to dynamically maintain the RP information. For configuring RP dynamically in the above scenario, R1 on eth-0-1 and R2 on eth-0-9 are configured as Candidate RP

using the ip pim rpcandidate command. R2 on eth-0-9 is also configured as Candidate BSR. Since no other router has been configured as Candidate BSR, the R2 becomes the BSR router, and is responsible for sending group-to-RP mapping information to all other routers in this PIM domain.

The following output displays the complete configuration at R1 and R2.

3.5.1 Configuration

R1

Switch# configure terminal	Enter the configure mode
Switch(config)# interface eth-0-1	Specify the interface (eth-0-1) to be configured and enter the Interface mode
Switch(config-if)# no shutdown	Turn up the interface
Switch(config-if)# no switchport	Change this port to Layer3 interface
Switch(config-if)# ip address 11.1.1.1/24	Configure IP address for this interface
Switch(config-if)# ip pim sparse-mode	Enable ip pim sparse mode
Switch(config-if)# exit	Exit the Interface mode and enter the Configure mode.
Switch(config)# interface eth-0-9	Specify the interface (eth-0-9) to be configured and enter the Interface mode
Switch(config-if)# no shutdown	Turn up the interface
Switch(config-if)# no switchport	Change this port to Layer3 interface
Switch(config-if)# ip address 12.1.1.1/24	Configure IP address for this interface
Switch(config-if)# ip pim sparse-mode	Enable ip pim sparse mode
Switch(config-if)# exit	Exit the Interface mode and enter the Configure mode.
Switch(config)# ip route 22.1.1.0/24 12.1.1.2	Configure a static route
Switch(config)# ip pim rp-candidate eth-0-1	Configure the candidate rp

R2

Switch# configure terminal	Enter the configure mode
Switch(config)# interface eth-0-1	Specify the interface (eth-0-1) to be configured and enter the Interface mode.
Switch(config-if)# no shutdown	Turn up the interface.
Switch(config-if)# no switchport	Change this port to Layer3 interface.
Switch(config-if)# ip address 22.1.1.2/24	Configure IP address for this interface
Switch(config-if)# ip pim sparse-mode	Enable ip pim sparse mode
Switch(config-if)# exit	Exit the Interface mode and enter the Configure mode.

Switch(config)# interface eth-0-9	Specify the interface (eth-0-9) to be configured and enter the Interface mode.
Switch(config-if)# no shutdown	Turn up the interface.
Switch(config-if)# no switchport	Change this port to Layer3 interface.
Switch(config-if)# ip address 12.1.1.2/24	Configure IP address for this interface
Switch(config-if)# ip pim sparse-mode	Enable ip pim sparse mode.
Switch(config-if)# exit	Exit the Interface mode and enter the Configure mode.
Switch(config)# ip route 11.1.1.0/24 12.1.1.1	Configure a static route.
Switch(config)# ip pim rp-candidate eth-0-9	Configure the candidate rp.
Switch(config)# ip pim bsr-candidate eth-0-9	Configure the candidate bsr.

The highest priority router is chosen as the RP. If two or more routers have the same priority, a hash function in the BSR mechanism is used to choose the RP, to make sure that all routers in the PIM-domain have the same RP for the same group.

Use the `ip pim rp-candidate IFNAME PRIORITY` command to change the default priority of any candidate RP.

3.5.2 Validation

PIM group-to-RP mappings

Use the `show ip pim sparse-mode rp mapping` command to display the group-to-RP mapping details. The output displays information about RP candidates. There are two RP candidates for the group range 224.0.0.0/4. RP Candidate 11.1.1.1 has a default priority of 192, whereas, RP Candidate 12.1.1.2 has been configured to have a priority of 2. Since RP candidate 12.1.1.2 has a higher priority, it is selected as RP for the multicast group 224.0.0.0/24. Only permit filters would be cared in group list.

```
R2# show ip pim sparse-mode rp mapping
PIM group-to-RP mappings
This system is the bootstrap router (v2)
Group(s): 224.0.0.0/4
  RP: 12.1.1.2
    Info source: 12.1.1.2, via bootstrap, priority 2
    Uptime: 01:55:20, expires: 00:02:17
  RP: 11.1.1.1
    Info source: 11.1.1.1, via bootstrap, priority 192
    Uptime: 01:55:23, expires: 00:02:13
```

RP details

To display information about the RP router for a particular group, use the following command. This output displays that 12.1.1.2 has been chosen as the RP for the multicast group 224.1.1.1.

```
R2# show ip pim sparse-mode rp-hash 224.1.1.1
RP: 12.1.1.2
Info source: 12.1.1.2, via bootstrap
```

After RP information reaches all PIM routers in the domain, various state machines maintain all routing states as the result of Join/Prune from group membership. To display information on interface details and the multicast routing table, refer to the Configuring RP Statically section above.

3.6 Configuring Bootstrap Router

Every PIM multicast group needs to be associated with the IP address of a Rendezvous Point (RP). This address is used as the root of a group-specific distribution tree whose branches extend to all nodes in the domain that want to receive traffic sent to the group. For all senders to reach all receivers, all routers in the domain use the same mappings of group addresses to RP addresses. In order to determine the RP for a multicast group, a PIM router maintains a collection of group-to-RP mappings, called the RP-Set.

The Bootstrap Router (BSR) mechanism for the class of multicast routing protocols in the PIM domain use the concept of a Rendezvous Point as a means for receivers to discover the sources that send to a particular multicast group. The BSR mechanism is one way that a multicast router can learn the set of group-to-RP mappings required in order to function.

Some of the PIM routers within a PIM domain are configured as Candidate-RPs (C-RPs). A subset of the C-RPs will eventually be used as the actual RPs for the domain. An RP configured with a lower value in the priority field has higher a priority.

Some of the PIM routers in the domain are configured to be Candidate-BSRs (C-BSRs). One of these C-BSRs is elected to be the bootstrap router (BSR) for the domain, and all PIM routers in the domain learn the result of this election through BSM (Bootstrap messages). The C-BSR with highest value in priority field is Elected-BSR.

The C-RPs then reports their candidacy to the elected BSR, which chooses a subset of the C-RPs and distributes corresponding group-to-RP mappings to all the routers in the domain through Bootstrap messages.

3.6.1 Topology

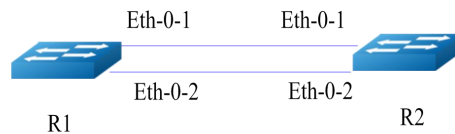

Figure 3-2 BSR Topology

3.6.2 Configuration

R1

Switch# configure terminal	Enter Configuration mode
Switch(config)# ip pim bsr-candidate eth-0-1	Configure eth-0-1 of rtr1 as C-BSR. The default priority is 64.

R2

Switch# configure terminal	Enter Configuration mode
Switch(config)# ip pim bsr-candidate eth-0-1 10 25	Configure eth-0-1 of rtr2 as C-BSR with a hash mask length 10 and a priority of 25.
Switch(config)# ip pim rp-candidate eth-0-1 priority 0	Configure interface eth-0-1 as C-RP with a priority of 0.

When the command `ip pim unicast-bsm` is configured on an interface which is a DR for that network, then that interface will unicast the stored copy of BSM to new/rebooting router.

Switch# configure terminal	Enter Configuration mode
Switch(config)# interface eth-0-1	Enter interface mode
Switch(config-if)# ip pim dr-priority 10	Configure the interface (eth-0-1) as DR
Switch(config-if)# ip pim unicast-bsm	Enable sending and receiving of Unicast BSM for backward compatibility.

3.6.3 Validation

Verify the C-BSR state on rtr1

```
Switch# show ip pim sparse-mode bsr-router
```

```
PIMv2 Bootstrap information
This system is the Bootstrap Router (BSR)
BSR address: 20.0.1.21
Uptime: 00:37:12, BSR Priority: 64, Hash mask length: 10
Next bootstrap message in 00:00:04
Role: Candidate BSR
State: Elected BSR
```

Verify the C-BSR state on rtr2

The initial state of C-BSR is P-BSR before transitioning to C-BSR.

```
Switch# show ip pim sparse-mode bsr-router
PIMv2 Bootstrap information
BSR address: 20.0.1.21
Uptime: 00:02:39, BSR Priority: 64, Hash mask length: 10
Expires: 00:00:03
Role: Candidate BSR
State: Pending BSR
Switch#show ip pim sparse-mode bsr-router
PIMv2 Bootstrap information
BSR address: 20.0.1.21
Uptime: 00:40:20, BSR Priority: 64, Hash mask length: 10
Expires: 00:02:07
Role: Candidate BSR
State: Candidate BSR
```

Verify RP-set information on E-BSR

```
Switch#sh ip pim sparse-mode rp mapping
PIM Group-to-RP Mappings
This system is the Bootstrap Router (v2)
Group(s): 224.0.0.0/4
RP: 20.0.1.11
Info source: 20.0.1.11, via bootstrap, priority 0
Uptime: 00:00:30, expires: 00:02:04
```

Verify RP-set information on C-BSR

```
Switch#show ip pim sparse-mode rp mapping
PIM Group-to-RP Mappings
Group(s): 224.0.0.0/4
RP: 20.0.1.11
Info source: 20.0.1.21, via bootstrap, priority 0
Uptime: 00:00:12, expires: 00:02:18
```

3.7 Configuring PIM-SSM feature

The Source Specific Multicast feature is an extension of IP multicast where datagram traffic is forwarded to receivers from only those multicast sources to which the receivers have explicitly joined. For multicast groups configured for SSM, only source-specific multicast distribution trees (no shared trees) are created.

PIM-SSM is the routing protocol that supports the implementation of SSM and is derived from PIM sparse mode (PIM-SM).

PIM-SSM can work with PIM-SM on the multicast router. By default, PIM-SSM is disabled

Switch# configure terminal	Enter Configuration mode
Switch(config)# ip pim ssm default	Enable pim-ssm on the switch and set the ssm group range as default
Switch(config)# ip pim ssm range ipacl	Enable pim-ssm on the switch and set the ssm group range as group range specified in ipacl

4 Configuring IGMP Snooping

4.1 Overview

Layer 2 switches can use IGMP snooping to constrain the flooding of multicast traffic by dynamically configuring Layer 2 interfaces so that multicast traffic is forwarded only to those interfaces associated with IP multicast devices. As the name implies, IGMP snooping requires the LAN switch to snoop on the IGMP transmissions between the host and the router and to keep track of multicast groups and member ports. When the switch receives an IGMP report from a host for a particular multicast group, the switch adds the host port number to the forwarding table entry; when it receives an IGMP Leave Group message from a host, it removes the host port from the table entry. It also deletes entries per entry if it does not receive IGMP membership reports from the multicast clients. The multicast router sends out periodic general queries to all VLANs. All hosts interested in this multicast traffic send report and are added to the forwarding table entry. The switch forwards only one report per IP multicast group to the multicast router. It creates one entry per VLAN in the Layer 2 forwarding table for each MAC group from which it receives an IGMP report.

Layer 2 multicast groups learned through IGMP snooping are dynamic. If you specify group membership for a multicast group address statically, your setting supersedes any automatic manipulation by IGMP snooping. Multicast group membership lists can consist of both user-defined and IGMP snooping-learned settings.

4.2 Enable Globally Or Per Vlan

4.2.1 Configuration

IGMP Snooping can be enabled globally or per vlan. If IGMP Snooping is disabled globally, it can't be active on any vlan even it is enabled on the vlan. If IGMP snooping is enabled globally, it can be disabled on a vlan. On the other hand, the global configuration can overwrite the per vlan configuration. By default, IGMP snooping is enabled globally and per vlan.

Switch# configure terminal	Enter Configuration mode
Switch(config)# ip igmp snooping	Enable igmp snooping globally

Switch(config)# ip igmp snooping vlan 1	Enable igmp snooping on vlan 1
Switch# show ip igmp snooping vlan 1	Verify ip igmp snooping configuration

4.2.2 Validation

```
Switch# show ip igmp snooping vlan 1
Global Igmp Snooping Configuration
-----
Igmp Snooping :Enabled
Igmp Snooping Fast-Leave :Disabled
Igmp Snooping Version :2
Igmp Snooping Robustness Variable :2
Igmp Snooping Max-Member-Number :2048
Igmp Snooping Unknown Multicast Behavior :Flood
Igmp Snooping Report-Suppression :Enabled
Vlan 1
-----
Igmp Snooping :Enabled
Igmp Snooping Fast-Leave :Disabled
Igmp Snooping Report-Suppression :Enabled
Igmp Snooping Version :2
Igmp Snooping Robustness Variable :2
Igmp Snooping Max-Member-Number :2048
Igmp Snooping Unknown Multicast Behavior :Flood
Igmp Snooping Group Access-list :N/A
Igmp Snooping Mrouter Port :
Igmp Snooping Mrouter Port Aging Interval(sec) :255
```

4.3 Configuring Fast Leave

4.3.1 Configuration

When IGMP Snooping fast leave is enabled, the igmp snooping group will be removed at once upon receiving a corresponding igmp report. Otherwise the switch will send out specified igmp specific query, if it doesn't get response in specified period, it will remove the group. By default, igmp snooping fast-leave is disabled globally and per vlan.

Switch# configure terminal	Enter Configuration mode
Switch(config)# ip igmp snooping fast-leave	Enable igmp snooping fast-leave globally
Switch(config)# ip igmp snooping vlan 1 fast-leave	Enable igmp snooping fast-leave on vlan 1
Switch# show ip igmp snooping vlan 1	Verify ip igmp snooping configuration.

4.3.2 Validation

```
Switch# show ip igmp snooping vlan 1
Global Igmp Snooping Configuration
-----
Igmp Snooping :Enabled
Igmp Snooping Fast-Leave :Enabled
Igmp Snooping Version :2
Igmp Snooping Robustness Variable :2
Igmp Snooping Max-Member-Number :2048
Igmp Snooping Unknown Multicast Behavior :Flood
Igmp Snooping Report-Suppression :Enabled
Vlan 1
-----
Igmp Snooping :Enabled
Igmp Snooping Fast-Leave :Enabled
Igmp Snooping Report-Suppression :Enabled
Igmp Snooping Version :2
Igmp Snooping Robustness Variable :2
Igmp Snooping Max-Member-Number :2048
Igmp Snooping Unknown Multicast Behavior :Flood
Igmp Snooping Group Access-list :N/A
Igmp Snooping Mrouter Port :
Igmp Snooping Mrouter Port Aging Interval(sec) :255
```

4.4 Configuring Querier Parameters

4.4.1 Configuration

In order for IGMP, and thus IGMP snooping, to function, an multicast router must exist on the network and generate IGMP queries. The tables created for snooping (holding the member ports for a each multicast group) are associated with the querier. Without a querier the tables are not created and snooping will not work.

Switch# configure terminal	Enter Configuration mode
Switch(config)# ip igmp snooping query-interval 100	Set igmp snooping query interval globally
Switch(config)# ip igmp snooping query-max-response-time 5	Set igmp snooping max query response time globally
Switch(config)# ip igmp snooping last-member-query-interval 2000	Set igmp snooping last member query interval globally
Switch(config)# ip igmp snooping vlan 1 querier address 10.10.10.1	Configure igmp snooping querier IP address on vlan 1
Switch(config)# ip igmp snooping vlan 1 querier	Enable igmp snooping querier on vlan 1
Switch(config)# ip igmp snooping vlan 1 query-interval 200	Set igmp snooping query interval on vlan 1

Switch(config)# ip igmp snooping vlan 1 query-max-response-time 5	Set igmp snooping max response time on vlan 1
Switch(config)# ip igmp snooping vlan 1 querier-timeout 100	Set igmp snooping querier timeout value on vlan 1
Switch(config)# ip igmp snooping vlan 1 last-member-query-interval 2000	Set igmp snooping last member query interval on vlan 1
Switch(config)# ip igmp snooping vlan 1 discard-unknown	Discard all unknown multicast packet in vlan 1
Switch(config)# ip igmp snooping discard-unknown	Discard all unknown multicast packet globally

4.4.2 Validation

```
Switch# show ip igmp snooping querier
Global Igmp Snooping Querier Configuration
-----
Version                               :2
Last-Member-Query-Interval (msec)     :2000
Last-Member-Query-Count               :2
Max-Query-Response-Time (sec)        :5
Query-Interval (sec)                  :100
Global Source-Address                  :0.0.0.0
TCN Query Count                       :2
TCN Query Interval (sec)              :10
TCN Query Max Respose Time (sec)     :5

Vlan 1:  IGMP snooping querier status
-----
Elected querier is : 0.0.0.0
-----
Admin state                           :Enabled
Admin version                          :2
Operational state                      :Non-Querier
Querier operational address            :10.10.10.1
Querier configure address              :10.10.10.1
Last-Member-Query-Interval (msec)     :2000
Last-Member-Query-Count               :2
Max-Query-Response-Time (sec)        :5
Query-Interval (sec)                  :200
Querier-Timeout (sec)                 :100
```

4.5 Configuring Mrouter Port

4.5.1 Configuration

An IGMP Snooping mrouter port is a switch port which is assumed to connect a multicast router. The mrouter port is configured on the vlan or learnt dynamic. When IGMP general query packet or PIMv2 hello packet is received on port of specified VLAN, this port becomes mrouter port of this

vlan. All the igmp queries received on this port will be flooded on the belonged vlan. All the igmp reports and leaves received on this vlan will be forwarded to the mrouter port, directly or aggregated, depending on the report-suppression configuration. In addition, all the multicast traffic on this vlan will be forwarded to this mrouter port.

Switch# configure terminal	Enter Configuration mode
Switch(config)# ip igmp snooping report-suppression	Enable igmp snooping report suppression globally
Switch(config)# ip igmp snooping vlan 1 mrouter interface eth-0-1	Configure mrouter port on vlan 1
Switch(config)# ip igmp snooping vlan 1 report-suppression	Enable igmp snooping report suppression on vlan 1
Switch(config)# ip igmp snooping vlan 1 mrouter-aging-interval 200	Set igmp snooping dynamic mrouter port aging interval

4.5.2 Validation

```
Switch# show ip igmp snooping vlan 1
Global Igmp Snooping Configuration
-----
Igmp Snooping                :Enabled
Igmp Snooping Fast-Leave      :Disabled
Igmp Snooping Version        :2
Igmp Snooping Robustness Variable :2
Igmp Snooping Max-Member-Number :2048
Igmp Snooping Unknown Multicast Behavior :Flood
Igmp Snooping Report-Suppression :Enabled
Vlan 1
-----
Igmp Snooping                :Enabled
Igmp Snooping Fast-Leave      :Disabled
Igmp Snooping Report-Suppression :Enabled
Igmp Snooping Version        :2
Igmp Snooping Robustness Variable :2
Igmp Snooping Max-Member-Number :2048
Igmp Snooping Unknown Multicast Behavior :Flood
Igmp Snooping Group Access-list :N/A
Igmp Snooping Mrouter Port    :eth-0-1
Igmp Snooping Mrouter Port Aging Interval(sec) :200
```

4.6 Configuring Querier Tcn

4.6.1 Configuration

Switch# configure terminal	Enter Configuration mode
Switch(config)# ip igmp snooping querier tcn query-count 5	Set igmp snooping querier tcn query-count globally

Switch(config)# ip igmp snooping querier tcn query-interval 20	Set ip igmp snooping querier tcn query-interval globally
--	--

4.6.2 Validation

```
Switch# show ip igmp snooping querier
Global Igmp Snooping Querier Configuration
-----
Version                               :2
Last-Member-Query-Interval (msec)    :1000
Max-Query-Response-Time (sec)       :10
Query-Interval (sec)                :125
Global Source-Address                :0.0.0.0
TCN Query Count                      :5
TCN Query Interval (sec)             :20

Vlan 1:  IGMP snooping querier status
-----
Elected querier is : 0.0.0.0
-----
Admin state                          :Disabled
Admin version                         :2
Operational state                    :Non-Querier
Querier operational address           :0.0.0.0
Querier configure address             :N/A
Last-Member-Query-Interval (msec)    :1000
Max-Query-Response-Time (sec)       :10
Query-Interval (sec)                :125
Querier-Timeout (sec)               :255
```

4.7 Configuring Report Suppression

4.7.1 Configuration

The switch uses IGMP report suppression to forward only one IGMP report per multicast router query to multicast devices. When IGMP router suppression is enabled (the default), the switch sends the first IGMP report from all hosts for a group to all the multicast routers. The switch does not send the remaining IGMP reports for the group to the multicast routers. This feature prevents duplicate reports from being sent to the multicast devices.

Switch# configure terminal	Enter Configuration mode
Switch(config)# ip igmp snooping report-suppression	Enable igmp snooping report suppression globally
Switch(config)# ip igmp snooping vlan 1 report-suppression	Enable igmp snooping report suppression on vlan 1

4.7.2 Validation

```
Switch# show ip igmp snooping
```

```

Global Igmp Snooping Configuration
-----
Igmp Snooping :Enabled
Igmp Snooping Fast-Leave :Disabled
Igmp Snooping Version :2
Igmp Snooping Robustness Variable :2
Igmp Snooping Max-Member-Number :2048
Igmp Snooping Unknown Multicast Behavior :Flood
Igmp Snooping Report-Suppression :Enabled
Vlan 1
-----
Igmp Snooping :Enabled
Igmp Snooping Fast-Leave :Disabled
Igmp Snooping Report-Suppression :Enabled
Igmp Snooping Version :2
Igmp Snooping Robustness Variable :2
Igmp Snooping Max-Member-Number :2048
Igmp Snooping Unknown Multicast Behavior :Flood
Igmp Snooping Group Access-list :N/A
Igmp Snooping Mrouter Port :
Igmp Snooping Mrouter Port Aging Interval(sec) :255

```

4.8 Configuring Static group

4.8.1 Configuration

The switch can build IGMP Snooping Group when receiving IGMP report packet on Layer 2 port of specified VLAN. We also support configure static IGMP Snooping Group by specifying IGMP group, Layer 2 port and VLAN.

Switch# configure terminal	Enter Configuration mode
Switch(config)# ip igmp snooping vlan 1 static-group 229.1.1.1 interface eth-0-2	Configure static group on port eth-0-2 of vlan2

4.8.2 Validation

```

Switch# show ip igmp snooping groups
VLAN  Interface      Group-Address  Uptime    Expires-time
1      eth-0-2          229.1.1.1     00:01:08  stopped

```

4.9 Limitations And Configuration Guidelines

VRRP, RIP and OSPF used multicast IP address, so you need to avoid use such multicast IP addresses, which have same multicast MAC address with multicast IP address reserved by VRRP, RIP and OSPF.

VRRP used multicast group address 224.0.0.18, so when igmp snooping and VRRP are working, you need to avoid using multicast group address that matched same mac address with group address 224.0.0.18.

OSPF used multicast group address 224.0.0.5, so when igmp snooping and OSFP are working, you need to avoid using multicast group address that matched same mac address with group address 224.0.0.18.

RIP used multicast group address 224.0.0.9, so when igmp snooping and RIP are working, you need to avoid using multicast group address that matched same mac address with group address 224.0.0.9.

5 Configuring MVR

5.1 Overview

Multicast VLAN Registration (MVR) is designed for applications using wide-scale deployment of multicast traffic across an Ethernet ring-based service provider network (for example, the broadcast of multiple television channels over a service-provider network). MVR allows a subscriber on a port to subscribe and unsubscribe to a multicast stream on the network-wide multicast VLAN. It allows the single multicast VLAN to be shared in the network while subscribers remain in separate VLANs. MVR provides the ability to continuously send multicast streams in the multicast VLAN, but to isolate the streams from the subscriber VLANs for bandwidth and security reasons.

MVR assumes that subscriber ports subscribe and unsubscribe (join and leave) these multicast streams by sending out IGMP join and leave messages. These messages can originate from an IGMP version-2-compatible host with an Ethernet connection. Although MVR operates on the underlying mechanism of IGMP snooping, the two features operation affect with each other. One can be enabled or disabled with affecting the behavior of the other feature. If IGMP snooping and MVR are both enabled, MVR reacts only to join and leave messages from multicast groups configured under MVR. The switch CPU identifies the MVR IP multicast streams and their associated MAC addresses in the switch forwarding table, intercepts the IGMP messages, and modifies the forwarding table to include or remove the subscriber as a receiver of the multicast stream, and the receivers must be in a different VLAN from the source. This forwarding behavior selectively allows traffic to cross between different VLANs.

5.2 Terminology

MVR: Multicast Vlan Registration.

Source vlan: The vlan for receiving multicast traffic for MVR.

Source port: The port in the source vlan for sending report or leave to upstream.

Receiver port: The port not in source vlan for receiving report or leave for downstream.

5.3 Topology

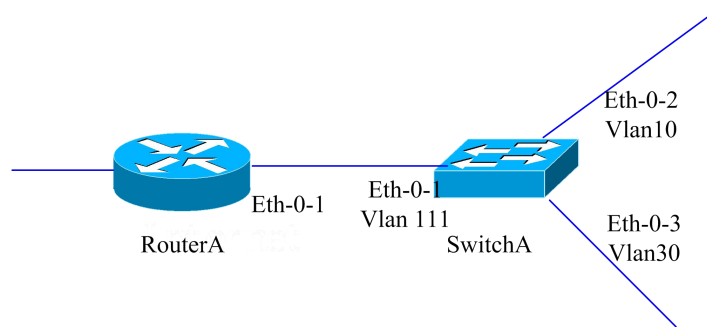

Figure 5-1 MVR Topology

5.4 Configurations

Purpose

Enable IGM P&PIM-SM in the interface of eth-0-1 of Router A.

Configure switch A: eth-0-1 in vlan111, eth-0-2 in vlan10, and eth-0-3 vlan30.

Enable MVR in the switchA, it is required that only one copy of multicast traffic from Router A is sent to switch A, but HostA and HostC can both receive this multicast traffic.

Router A

Enable ip pim-sm and igmp in the eth-0-1.

RouterA# configure terminal	Enter the configure mode
RouterA (config)# interface eth-0-1	Enter the Interface mode
RouterA (config-if)# no switchport	Configure on physical port only, change this port to Layer3 interface
RouterA (config-if)# no shutdown	Enable this interface
RouterA (config-if)# ip address 12.12.12.12/24	Configure IP address to 12.12.12.12/24
RouterA (config-if)# ip pim sparse-mode	Enable pim sparse-mode on interface
RouterA (config-if)# end	Return to privileged EXEC mode

Switch A

Eth-0-1 in vlan111, eth-0-2 in vlan10, and eth-0-3 vlan30.

SwitchA# configure terminal	Enter the configure mode
SwitchA(config)# vlan database	Enter VLAN database mode

SwitchA(config-vlan)# vlan 111,10,30	Creat vlan 111,10,30
SwitchA(config-vlan)# quit	Quit the VLAN database mode and return to Configure mode to configure the next interface.
SwitchA(config)# interface vlan 111	Create Source VLAN interface
SwitchA(config-if)# exit	Return to Config mode
SwitchA(config)# interface vlan 10	Create Receiver VLAN interface
SwitchA(config-if)# exit	Return to Config mode
SwitchA(config)# interface vlan 30	Create Receiver VLAN interface
SwitchA(config-if)# exit	Return to Config mode
SwitchA(config)# interface eth-0-1	Enter the Interface mode
SwitchA(config-if)# switchport access vlan111	Enable VLAN port access by specifying the VLAN ID 111 on this interface
SwitchA(config)# interface eth-0-2	Enter the Interface mode.
SwitchA(config-if)# switchport access vlan10	Enable VLAN port access by specifying the VLAN ID 10 on this interface
SwitchA(config)# interface eth-0-3	Enter the Interface mode.
SwitchA(config-if)# switchport access vlan30	Enable VLAN port access by specifying the VLAN ID 30 on this interface
SwitchA(config-if)# end	Return to privileged EXEC mode

Enable MVR in the switchA, it is required that only one copy of multicast traffic from Router A is sent to switchA, but HostA and HostC can both receiver this multicast traffic.

SwitchA # configure terminal	Enter the configure mode
SwitchA(config)# no ip multicast-routing	Disable ip multicast-routing
SwitchA(config)# mvr	Enable Multicast Vlan Registration
SwitchA(config)# mvr vlan 111	Configure mvr vlan
SwitchA(config)# mvr group 238.255.0.1 64	Configure mvr group address
SwitchA(config)# mvr source-address 12.12.12.1	Configure mvr source-address
SwitchA(config)# interface eth-0-1	Enter the Interface mode
SwitchA(config-if)# mvr type source	Configure the port to mvr type source
SwitchA(config)# interface eth-0-2	Enter the Interface mode
SwitchA(config-if)# mvr type receiver vlan 10	Configure the port to mvr type receiver
SwitchA(config)# interface eth-0-3	Enter the Interface mode
SwitchA(config-if)# mvr type receiver vlan 30	Configure the port to mvr type receiver
SwitchA(config-if)# end	Return to privileged EXEC mode

5.5 Validation

Router A

```
RouterA # show ip igmp groups
IGMP Connected Group Membership
Group Address      Interface          Uptime    Expires    Last Reporter
238.255.0.1        eth-0-1           00:01:16 00:03:49 12.12.12.1
238.255.0.2        eth-0-1           00:01:16 00:03:49 12.12.12.1
238.255.0.3        eth-0-1           00:01:16 00:03:49 12.12.12.1
238.255.0.4        eth-0-1           00:01:16 00:03:49 12.12.12.1
238.255.0.5        eth-0-1           00:01:16 00:03:49 12.12.12.1
238.255.0.6        eth-0-1           00:01:16 00:03:49 12.12.12.1
238.255.0.7        eth-0-1           00:01:16 00:03:49 12.12.12.1
238.255.0.8        eth-0-1           00:01:16 00:03:49 12.12.12.1
238.255.0.9        eth-0-1           00:01:16 00:03:49 12.12.12.1
238.255.0.10       eth-0-1           00:01:16 00:03:49 12.12.12.1
.....
238.255.0.64       eth-0-1           00:01:16 00:03:49 12.12.12.1
```

Switch A

```
SwitchA# show mvr
MVR Running: TRUE
MVR Multicast VLAN: 111
MVR Source-address: 12.12.12.1
MVR Max Multicast Groups: 1024
MVR Hw Rt Limit: 508
MVR Current Multicast Groups: 255
```

```
SwitchA# show mvr groups
VLAN  Interface      Group-Address      Uptime    Expires-time
10    eth-0-2        238.255.0.1        00:03:23  00:02:03
10    eth-0-2        238.255.0.2        00:02:16  00:02:03
10    eth-0-2        238.255.0.3        00:02:16  00:02:03
10    eth-0-2        238.255.0.4        00:02:16  00:02:03
10    eth-0-2        238.255.0.5        00:02:16  00:02:03
10    eth-0-2        238.255.0.6        00:02:16  00:02:04
10    eth-0-2        238.255.0.7        00:02:16  00:02:04
10    eth-0-2        238.255.0.8        00:02:16  00:02:04
10    eth-0-2        238.255.0.9        00:02:16  00:02:04
10    eth-0-2        238.255.0.10       00:02:16  00:02:04
.....
10    eth-0-2        238.255.0.64       00:01:50  00:02:29
```