

S3900 SERIES MANAGED L2+ GIGABIT SWITCHES

MANAGED-L2+-GIGABIT-SWITCH DER S3900-SERIE
SWITCHS MANAGEABLES L2+ GIGABIT DE LA SÉRIE S3900

Quick Start Guide **V1.0**

Quick-Start Anleitung

Guide de Démarrage Rapide

Introduction

Thank you for choosing S3900 Series Stackable Managed Switches. This guide is designed to familiarize you with the layout of the switch and describes how to deploy the switch in your network.

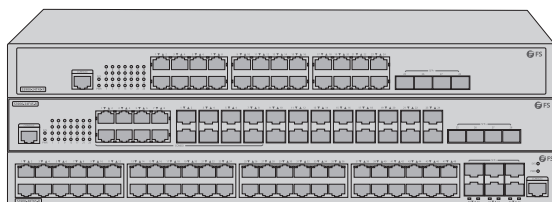

S3900-24T4S-R

S3900-24F4S-R

S3900-48T6S-R

Accessories

S3900-24T4S-R



Power Cord x 2



Console Cable x 1



Mounting Bracket x 2



Grounding Cable x 1



Rubber Pad x 4



M3 Screw x 6

S3900-24F4S-R

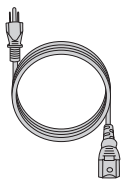

Power Cord x 2

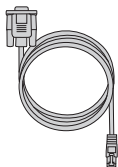

Console Cable x 1



Mounting Bracket x 2



Grounding Cable x 1



Rubber Pad x 4



M3 Screw x 8

S3900-48T6S-R

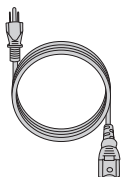

Power Cord x 2

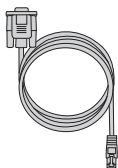

Console Cable x 1



Mounting Bracket x 2



Grounding Cable x 1



Rubber Pad x 4



M3 Screw x 8



NOTE: S3900 series switches have dust plugs delivered with them. Keep the dust plugs properly and use them to protect idle optical ports.

Hardware Overview

Front Panel Ports

S3900-24T4S-R

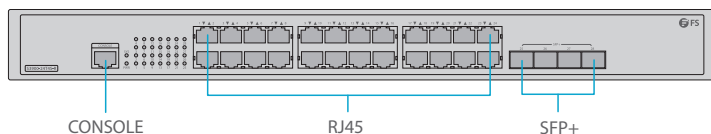

S3900-24F4S-R

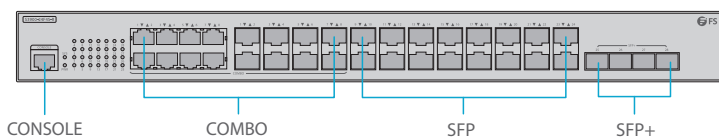

S3900-48T6S-R

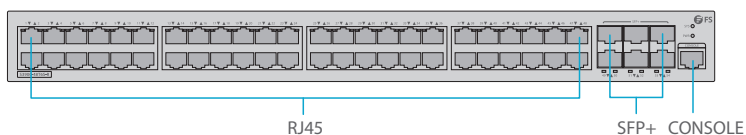

Ports	Description
RJ45	10/100/1000BASE-T ports for Ethernet connection
SFP	SFP ports for 1G connection
SFP+	SFP+ ports for 1/10G connection
CONSOLE	An RJ45 console port for serial management
COMBO	One RJ45 port and one SFP slot, with one port active at a time

Front Panel LEDs

S3900-24T4S-R

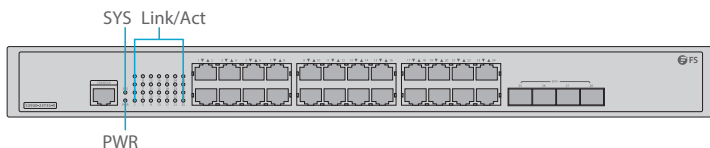

S3900-24F4S-R

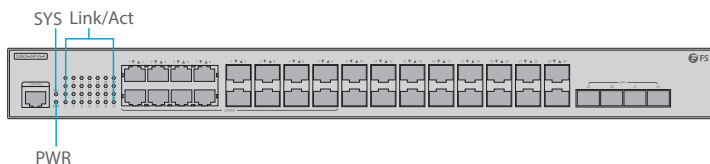

S3900-48T6S-R

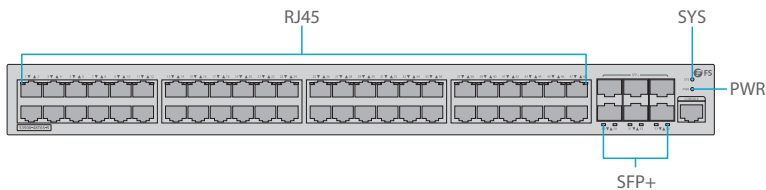

LEDs	Status	Description
PWR	Green	Switch is powered on.
SYS	Green	System is working properly.
	Blinking Green	System is started normally.
	Off	System is not working properly.
Link/Act	Green	Data is being transmitted or received.
	Off	no signal transmission.
RJ45/SFP+	Green	Data is being transmitted or received.
	Off	No device is connected to the corresponding port.

Back Panels

S3900-24T4S-R

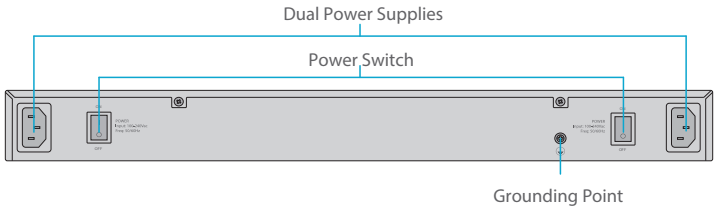

S3900-24F4S-R / S3900-48T6S-R

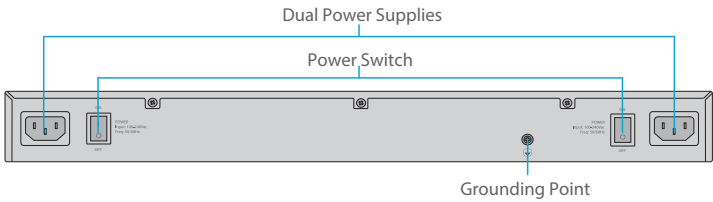

Button	Description
Power switch	ON means the power is switched on, while OFF means the power is cut off.

Installation Requirements

Only professionals are allowed to install or replace the switch. Before you begin the installation, make sure that you have the following:

- Screwdriver
- Static-proof wristband
- Ethernet cable
- Other Ethernet terminal devices
- Control terminal

Site Environment:

- Do not operate it in an area that exceeds an ambient temperature of 50°C.
- The installation site must be well ventilated. Ensure that there is adequate air flow around the switch.
- Be sure that the switch is level and stable to avoid any hazardous conditions.
- Do not install the equipment in a dusty environment.
- The installation site must be free from leaking or dripping water, heavy dew, and humidity.
- Ensure rack and working platforms are well earthed.

Mounting the Switch

Desk Mounting

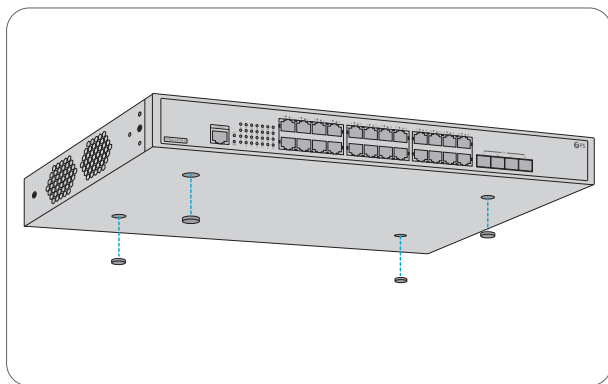

1. Attach four rubber pads to the bottom.
2. Place the chassis on a desk.



NOTE: Do not put things weighing 4.5 kg or over 4.5 kg on the top of the switch.

Rack Mounting

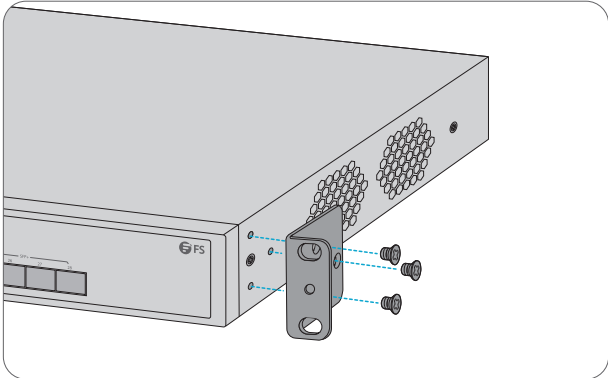

1. Secure the mounting brackets to the two sides of the switch with M4 screws.

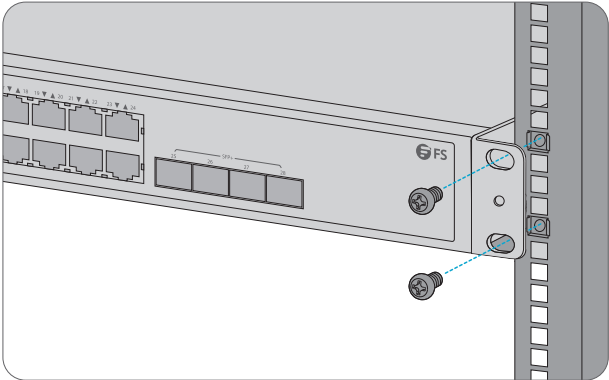

2. Attach the switch to the rack using M6 screws and cage nuts.

Grounding the Switch

EN

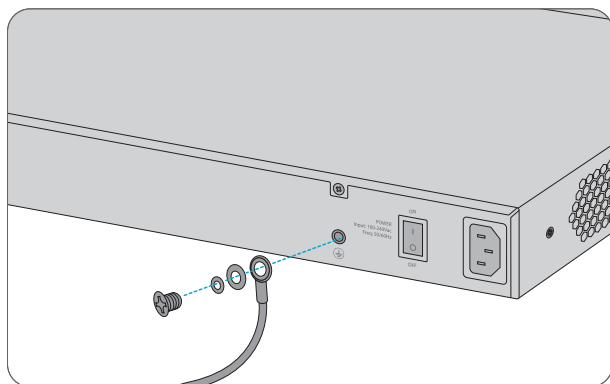

1. Connect one end of the grounding cable to a proper earth ground, such as the rack in which the switch is mounted.
2. Secure the grounding lug to the grounding point on the switch back panel with the washers and screws.



CAUTION: The earth connection must not be removed unless all supply connections have been disconnected.

Connecting the Power

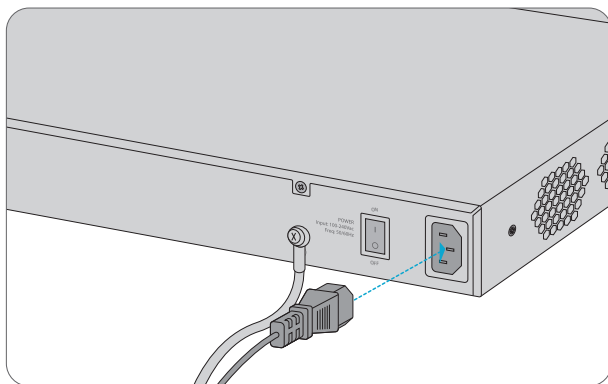

1. Plug the AC power cord into the power port on the back of the switch.
2. Connect the other end of the power cord to an AC power source.



WARNING: Do not install power cable while the power is on.

Connecting the RJ45 Ports

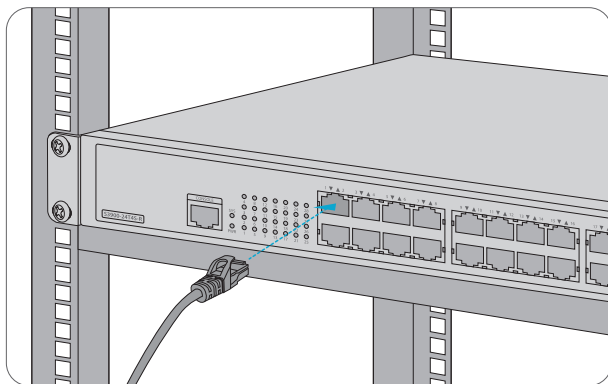

1. Connect an Ethernet cable to the RJ45 port of a computer, printer, network storage, or other network devices.
2. Connect the other end of the Ethernet cable to the RJ45 port of the switch.

Connecting the SFP+

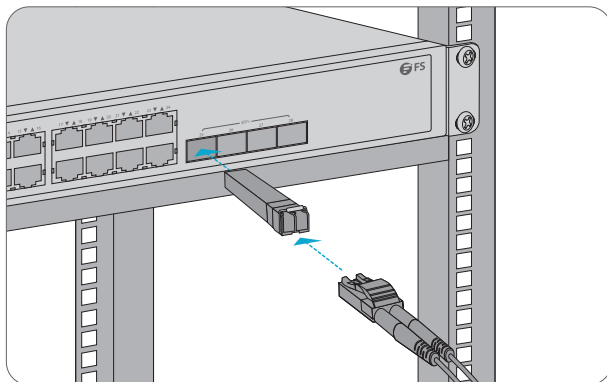

1. Plug the compatible SFP+/SFP transceiver into the SFP+ port.
2. Connect a fiber optic cable to the fiber transceiver. Then connect the other end of the cable to another fiber device.



WARNING: Laser beams will cause eye damage. Do not look into bores of optical modules or optical fibers without eye protection.

Connecting the Console Port

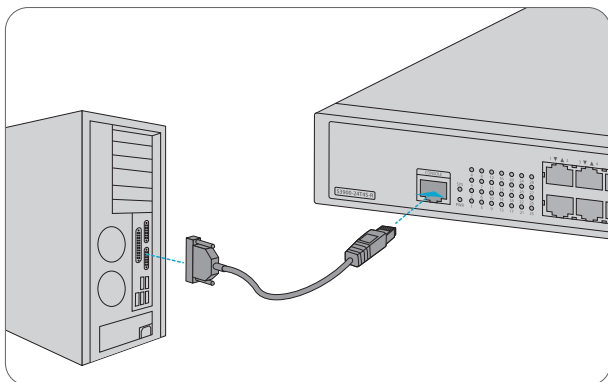

1. Insert the RJ45 connector into the RJ45 console port on the front of the switch.
2. Connect the DB9 female connector of the console cable to RS-232 serial port on the computer.

Stacking the S3900 Series Switches

S3900-24T4S-R&S3900-24F4S-R support 8 units hybrid-stacking together. S3900-48T6S-R supports 6 units stacking between same models. Switches can be physically stacked using optical fiber cables connected to SFP+ transceivers, or 10G Direct Attach Cables (DAC). All SFP+ ports on the switch can be used for physical stacking.

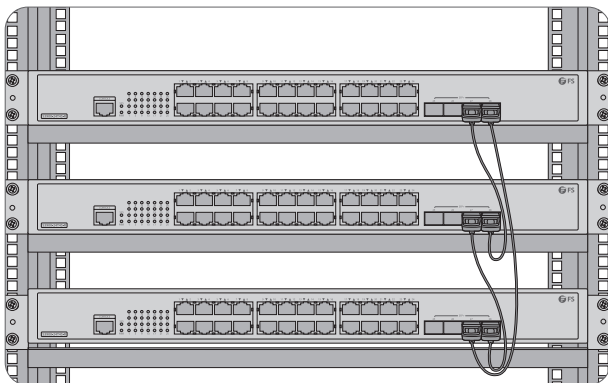

Configuring the Switch

Configuring the Switch Using the Web-based Interface

Step 1: Connect your computer to any Ethernet port of the switch using the network cable.

Step 2: Set the IP address of the computer to 192.168.1.x. ("x" is any number from 2 to 254.)

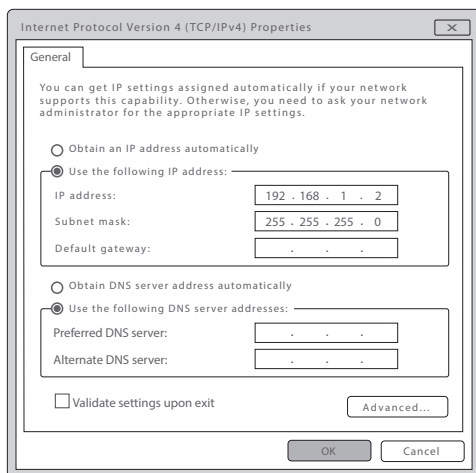

Step 3: Open a browser, type <http://192.168.1.1>, and enter the default username and password.

Step 4: Click Login to display the web-based configuration page.

Configuring the Switch Using the Console Port

Step 1: Connect a computer to the switch's console port using the supplied console cable.

Step 2: Start the terminal simulation software such as HyperTerminal on the computer.

Step 3: Set the parameters of the HyperTerminal: 115200 bits per second, 8 data bits, no parity, 1 stop bit and no flow control.

Quick Connect

Protocol:

The port may be manually entered or selected from the list.

Port:

Baud rate:

Data bits:

Parity:

Stop bits:

Name of pipe:

Flow Control

DTR/DSR

RTS/CTS

XON/XOFF

Show quick connect on startup

Save session

Open in a tab

Troubleshooting

1/10G Port is not Working

In the case of compatible cables and transceivers, the port cannot be up, please try to modify the port mode to adapt or force the port speed to 1G/10G.

Connecting the Switch Remotely Unsuccessfully

1. Test network connectivity through ping.
2. If the network is reachable, try restarting the switch.
3. Check if the corresponding service is enabled.

The Port is not Working, the LED Indicator is Off

1. Ensure the switch ports are in the no shutdown state.
2. Check if the switch can read the DDM information.
3. Check if the port speed setting is correct.
4. Try looping the switch cable.

Support and Other Resources

- Download <https://www.fs.com/download.html>
- Help Center https://www.fs.com/service/help_center.html
- Contact Us https://www.fs.com/contact_us.html

Product Warranty

FS ensures our customers that any damage or faulty items due to our workmanship, we will offer a free return within 30 Days from the day you receive your goods. This excludes any custom made items or tailored solutions.



Warranty: S3900 Series Switches enjoy 4 years limited warranty against defect in materials or workmanship. For more details about warranty, please check at <https://www.fs.com/policies/warranty.html>



Return: If you want to return item(s), information on how to return can be found at https://www.fs.com/policies/day_return_policy.html

Einführung

Vielen Dank, dass Sie sich für die Stackable Managed Switches der S3900-Serie entschieden haben. Diese Anleitung soll Sie mit dem Layout des Switches vertraut machen und beschreibt, wie Sie den Switch in Ihrem Netzwerk einsetzen.

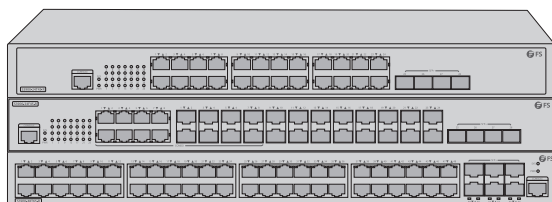

S3900-24T4S-R

S3900-24F4S-R

S3900-48T6S-R

Zubehör

S3900-24T4S-R



Netz kabel x 2

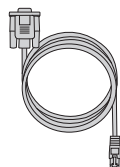

Konsolenkabel x 1



Montagehalterung x 2



Erdungskabel x 1



Gummipad x 4



M4 Schraube x 6

S3900-24F4S-R

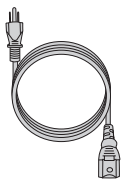

Netzwerk-Kabel x 2

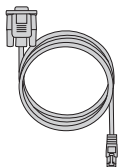

Konsolen-Kabel x 1



Montagehalterung x 2



Erdungskabel x 1



Gummipad x 4



M4-Schraube x 8

S3900-48T6S-R

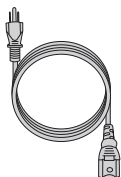

Netzwerk-Kabel x 2

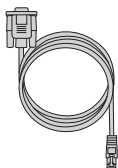

Konsolen-Kabel x 1



Montagehalterung x 2



Erdungskabel x 1



Gummipad x 4



M4-Schraube x 8



HINWEIS: Bei den Switches der S3900-Serie werden Staubschutzkappen mitgeliefert. Bewahren Sie bitte die Staubschutzkappen ordnungsgemäß auf und verwenden Sie sie zum Schutz ungenutzter optischer Ports.

Hardware-Übersicht

Ports an der Vorderseite

S3900-24T4S-R

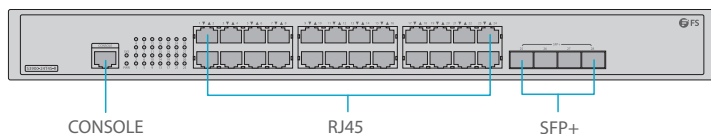

S3900-24F4S-R

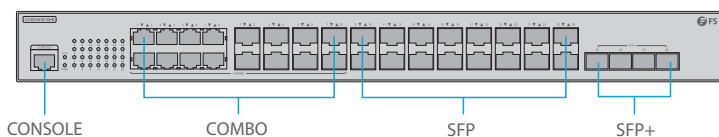

S3900-48T6S-R

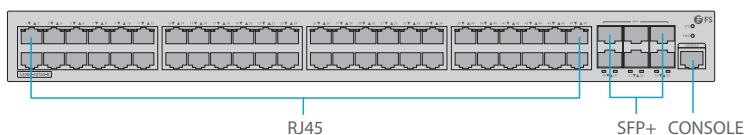

Ports	Beschreibung
RJ45	10/100/1000BASE-T Ports für Ethernet-Anschluss
SFP	SFP+-Ports für 1G-Anschluss
SFP+	SFP+-Ports für 1/10G-Anschluss
CONSOLE	RJ45 Console-Port für die serielle Verwaltung
COMBO	Ein RJ45-Port und ein SFP-Steckplatz, wobei jeweils ein Port aktiv ist

LEDs an der Vorderseite

S3900-24T4S-R

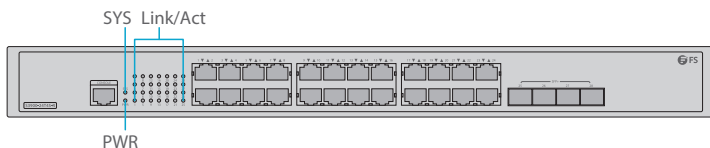

S3900-24F4S-R

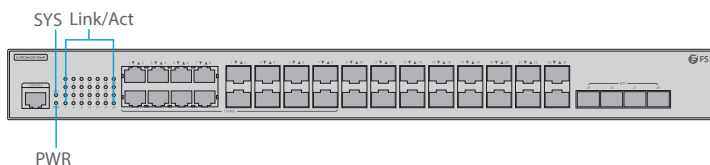

S3900-48T6S-R

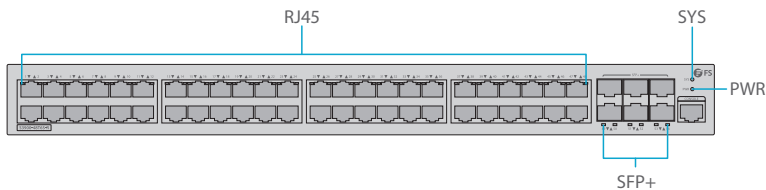

LEDs	Status	Beschreibung
PWR	Grün	Switch ist eingeschaltet.
SYS	Grün	Das System funktioniert ordnungsgemäß.
	Blinkend Grün	Das System wird normal gestartet.
	Aus	Das System funktioniert nicht ordnungsgemäß.
Link/Act	Grün	Es werden Daten gesendet oder empfangen.
	Aus	Keine Signalübertragung.
RJ45/SFP+	Grün	Es werden Daten übertragen oder empfangen.
	Aus	Es ist kein Gerät an den entsprechenden Port angeschlossen.

Rückseite

S3900-24T4S-R

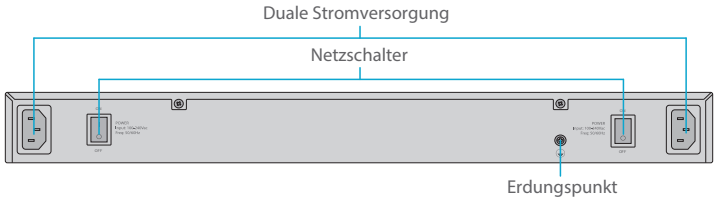

S3900-24F4S-R / S3900-48T6S-R

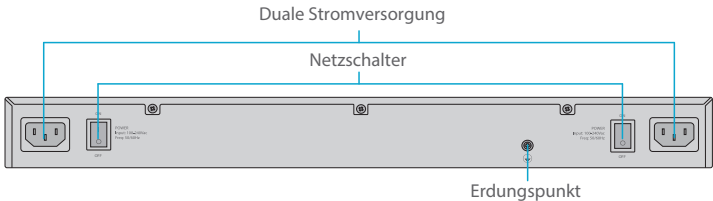

Taste	Beschreibung
Power switch	ON bedeutet, dass der Strom eingeschaltet ist, während OFF bedeutet, dass der Strom abgeschaltet ist.

Installationsvoraussetzungen

Die Installation oder der Austausch des Switches darf nur von Fachleuten vorgenommen werden.

Bevor Sie mit der Installation beginnen, vergewissern Sie sich, dass Sie über die folgenden Utensilien verfügen:

- Schraubenzieher
- Antistatik-Armband
- Ethernet-Kabel
- Andere Ethernet-Endgeräte
- Steuerterminal

Standortumgebung:

- Betreiben Sie das Gerät nicht in einem Bereich, in dem die Umgebungstemperatur 50°C übersteigt.
- Der Installationsort muss gut belüftet sein. Stellen Sie sicher, dass um den Switch herum ein ausreichender Luftstrom herrscht.
- Achten Sie darauf, dass der Switch eben und stabil steht, um gefährliche Bedingungen zu vermeiden.
- Installieren Sie das Gerät nicht in einer staubigen Umgebung.
- Der Installationsort muss frei von austretendem oder tropfendem Wasser, starkem Tau und Feuchtigkeit sein.
- Stellen Sie sicher, dass Gestell und Arbeitsbühnen gut geerdet sind.

Montage des Switches

Montage auf einem Tisch

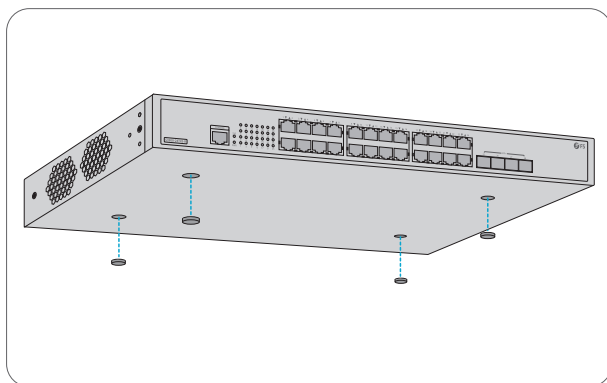

1. Bringen Sie vier Gummipads an der Unterseite an.
2. Stellen Sie das Gehäuse auf den Tisch.



HINWEIS: Stellen Sie keine Gegenstände mit einem Gewicht über 4,5 kg auf die Oberseite des Switches.

Rack-Montage

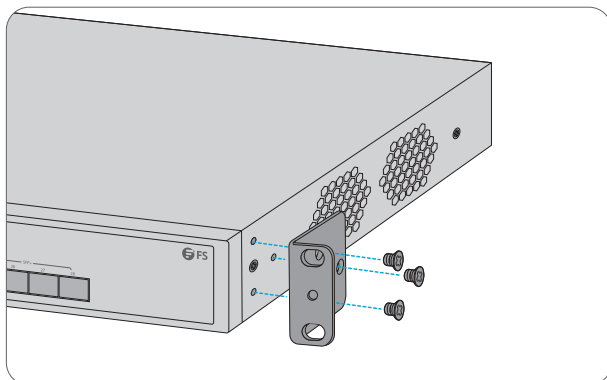

1. Befestigen Sie die Montagehalterungen mit M4-Schrauben an den beiden Seiten des Switches.

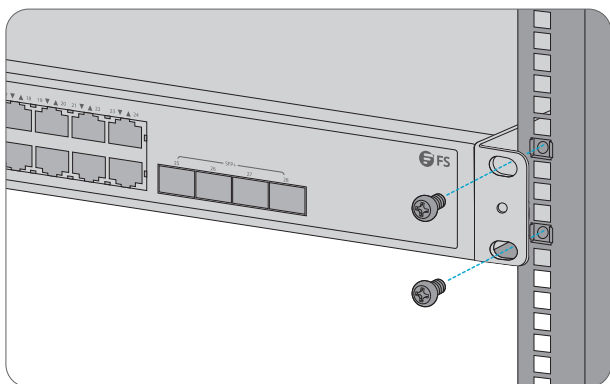

2. Befestigen Sie den Switch mit M6-Schrauben und Käfigmuttern am Rack.

Erdung des Switches

DE

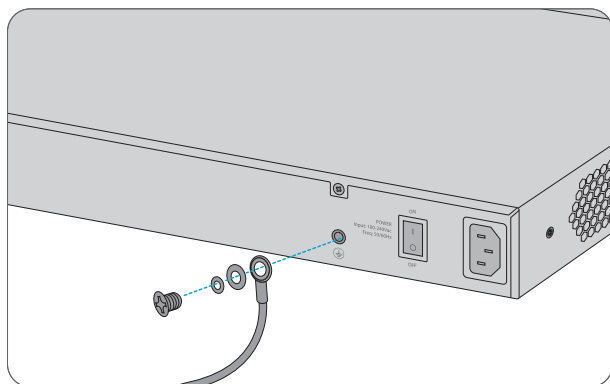

1. Schließen Sie ein Ende des Erdungskabels an eine geeignete Erdung an, z. B. an das Rack, in dem der Switch montiert ist.
2. Befestigen Sie die Erdungsglasche mit den Unterlegscheiben und Schrauben am Erdungspunkt an der Rückwand des Switches.



ACHTUNG: Der Erdungsanschluss darf erst dann entfernt werden, wenn alle Versorgungsanschlüsse abgezogen wurden.

Anschluss der Stromversorgung

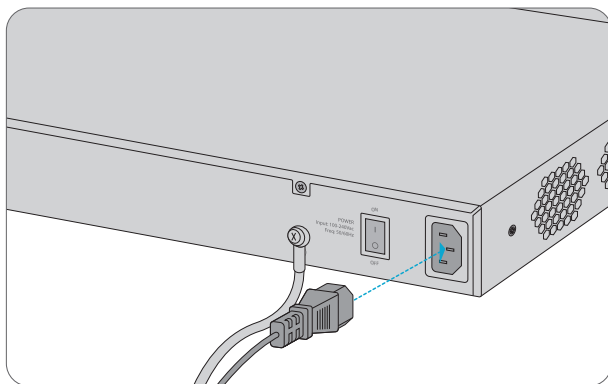

1. Stecken Sie das Netzkabel in den Port auf der Rückseite des Switches.
2. Schließen Sie das andere Ende des Netzkabels an eine Netzstromquelle an.



WARNUNG: Schließen Sie das Netzkabel nicht an, wenn das Gerät eingeschaltet ist.

Anschluss der RJ45-Ports

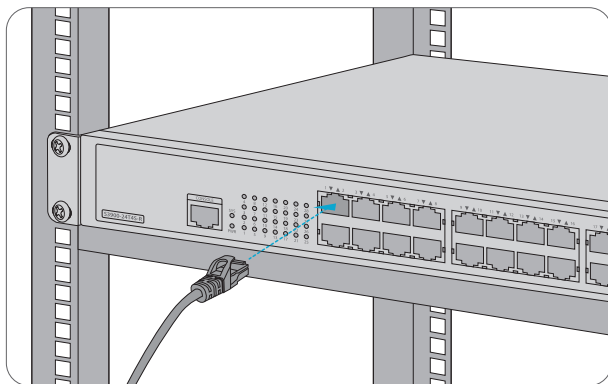

1. Schließen Sie ein Ethernet-Kabel an den RJ45 Port eines Computers, Druckers, Netzwerkspeichers oder anderer Netzwerkgeräte an.
2. Schließen Sie das andere Ende des Ethernet-Kabels an den RJ45-Port des Switches an.

Anschluss der SFP+-Ports

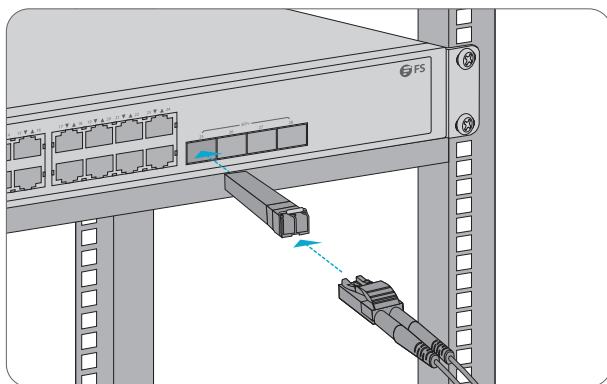

1. Stecken Sie den kompatiblen SFP+/SFP-Transceiver in den SFP+-Port.
2. Schließen Sie ein Glasfaserkabel an den Glasfasertransceiver an. Schließen Sie dann das andere Ende des Kabels an ein anderes Glasfasergerät an.



WARNUNG: Laserstrahlen können zu Augenschäden führen. Schauen Sie nicht ohne Augenschutz in die Bohrungen von optischen Modulen oder Glasfasern.

Anschluss des Console-Ports

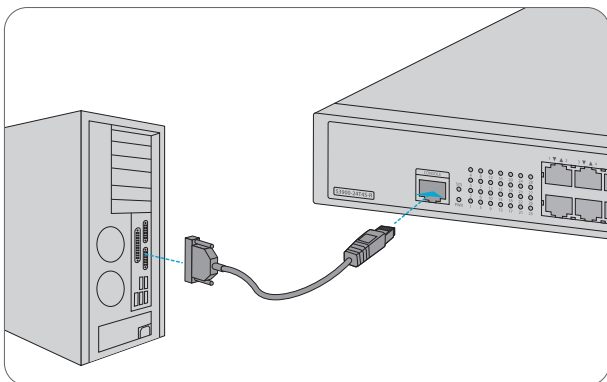

1. Stecken Sie den RJ45-Stecker in den RJ45 Console-Port an der Vorderseite des Switches.
2. Verbinden Sie die DB9-Buchse des Console-Kabels mit dem seriellen RS-232 Port des Computers.

Stacking von Switches der S3900-Serie

S3900-24T4S-R&S3900-24F4S-R unterstützen das Hybrid-Stacking von 8 Einheiten untereinander. S3900-48T6S-R unterstützt das Stacking von 6 Einheiten zwischen denselben Modellen. Die Switches können mit Glasfaserkabeln, die an SFP+-Transceiver angeschlossen sind, oder mit 10G Direct Attach Kabeln (DAC) physisch gestapelt werden. Alle SFP+-Ports des Switches können für physisches Stacking verwendet werden.

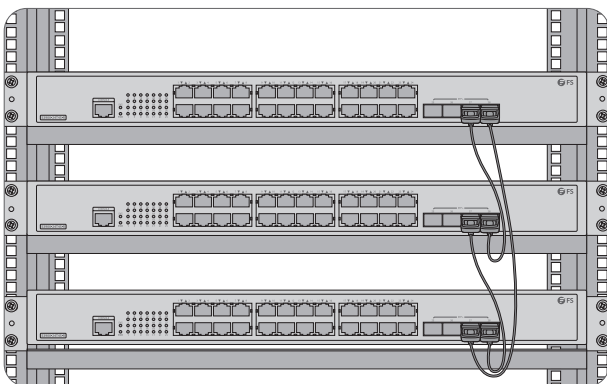

Konfiguration des Switches

Konfiguration des Switches über die webbasierte Schnittstelle

Schritt 1: Schließen Sie Ihren Computer über das Netzkabel an einen beliebigen Ethernet Port des Switches an.

Schritt 2: Stellen Sie die IP-Adresse des Computers auf **192.168.1.x** ein. ("x" ist eine beliebige Zahl zwischen 2 und 254.)

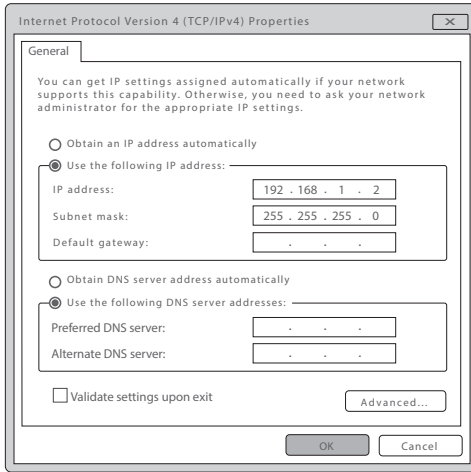

Schritt 3: Öffnen Sie einen Browser, geben Sie **http://192.168.1.1** ein, und geben Sie den Standard-Benutzernamen und das Passwort ein.

Schritt 4: Klicken Sie auf Anmelden, um die webbasierte Konfigurationsseite anzuzeigen.

Konfiguration des Switches über den Console-Port

Schritt 1: Schließen Sie einen Computer über das mitgelieferte Konsolenkabel an den Console-Port des Switches an.

Schritt 2: Starten Sie die Terminalsimulationssoftware, z. B. HyperTerminal, auf dem Computer.

Schritt 3: Stellen Sie die Parameter von HyperTerminal ein: 115200 Bits pro Sekunde, 8 Datenbits, keine Parität, 1 Stopbit und keine Flow Control.

Quick Connect

Protocol:

The port may be manually entered or selected from the list.

Port:

Baud rate:

Data bits:

Parity:

Stop bits:

Name of pipe:

Flow Control

DTR/DSR

RTS/CTS

XON/XOFF

Show quick connect on startup

Save session

Open in a tab

Fehlerbehebung

1/10G-Port funktioniert nicht

Wenn der Port bei kompatiblen Kabeln und Transceivern nicht funktioniert, versuchen Sie bitte, den Port-Modus zu ändern, um die Geschwindigkeit des Ports auf 1G/10G anzupassen oder zu erzwingen.

Fehlgeschlagene Remote-Verbindung des Switches

1. Testen Sie die Netzwerkkonnektivität durch Ping.
2. Wenn das Netzwerk erreichbar ist, versuchen Sie, den Switch neu zu starten.
3. Prüfen Sie, ob der entsprechende Dienst aktiviert ist.

Der Port funktioniert nicht, die LED-Anzeige ist aus

1. Vergewissern Sie sich, dass die Ports des Switches nicht heruntergefahren sind.
2. Prüfen Sie, ob der Switch die DDM-Informationen lesen kann.
3. Prüfen Sie, ob die Geschwindigkeitseinstellung des Ports korrekt ist.
4. Versuchen Sie, das Kabel des Switches in einer Schleife zu verlegen.

DE

Support und andere Ressourcen

- Downloads <https://www.fs.com/de/download.html>
- Hilfecenter https://www.fs.com/de/service/fs_support.html
- Kontakt https://www.fs.com/de/contact_us.html

Produktgarantie

Wir garantieren unseren Kunden, dass wir bei Schäden oder fehlerhaften Artikeln, die auf unsere Verarbeitung zurückzuführen sind, eine kostenlose Rückgabe innerhalb von 30 Tagen nach Erhalt der Ware gewähren. Dies gilt nicht für Sonderanfertigungen oder maßgeschneiderte Lösungen.



Garantie: Für Switches der S3900-Serie gilt eine beschränkte Garantie von 4 Jahren auf Material- und Verarbeitungsfehler. Weitere Einzelheiten zur Garantie finden Sie unter: <https://www.fs.com/de/policies/warranty.html>



Rückgabe: Wenn Sie Artikel zurücksenden möchten, finden Sie Informationen unter: https://www.fs.com/de/policies/day_return_policy.html

Introduction

Merci d'avoir choisi le Switch Manageable Empilable de la Série S3900. Ce guide est conçu pour que vous puissiez vous familiariser avec la configuration du switch et décrit comment procéder à son déploiement.

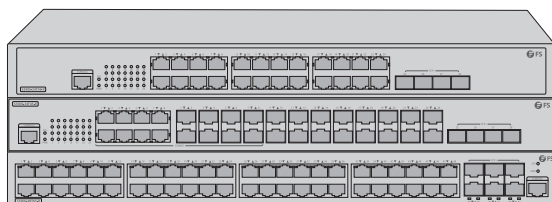

S3900-24T4S-R

S3900-24F4S-R

S3900-48T6S-R

FR

Accessoires

S3900-24T4S-R



Câble d'Alimentation x 2

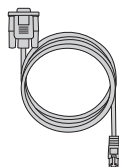

Câble de Console x 1



Support de Montage x 2



Câble de Mise à Terre x 1



Coussins en Caoutchouc x 4



Vis M4 x 6

S3900-24F4S-R

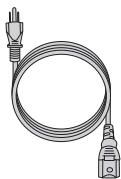

Câble d'Alimentation x 2

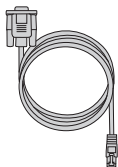

Câble de Console x 1



Support de Montage x 2



Câble de Mise à Terre x 1



Coussins en Caoutchouc x 4



Vis M4 x 8

S3900-48T6S-R

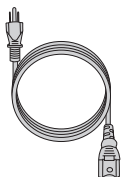

Câble d'Alimentation x 2

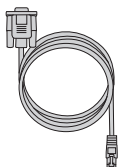

Câble de Console x 1



Support de Montage x 2



Câble de Mise à Terre x 1



Coussins en Caoutchouc x 4



Vis M4 x 8



NOTE: Les switches de la série S3900 sont livrés avec des capuchons anti-poussière. Veuillez conserver les capuchons anti-poussière et les utiliser pour la protection des ports optiques inactifs.

Aperçu du Matériel

Ports du Panneau Frontal

S3900-24T4S-R

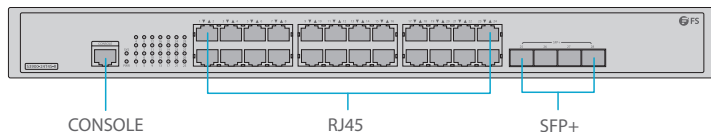

S3900-24F4S-R

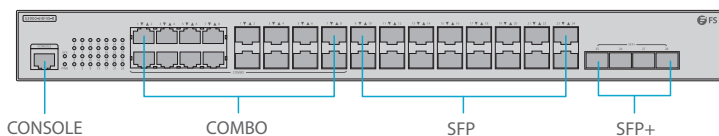

S3900-48T6S-R

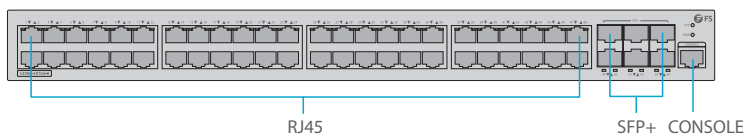

Ports	Description
RJ45	Ports 10/100/1000BASE-T pour une connexion Ethernet
SFP	Ports SFP pour une connexion 1G
SFP+	Ports SFP+ pour une connexion 1/10G
CONSOLE	Un port console RJ45 pour la gestion en série
COMBO	Un port RJ45 et une rainure SFP, dont un seul port est actif à la fois

Indicateurs LED du Panneau Frontal

S3900-24T4S-R

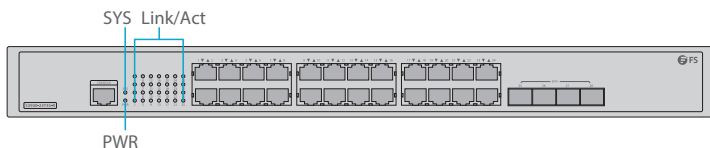

S3900-24F4S-R

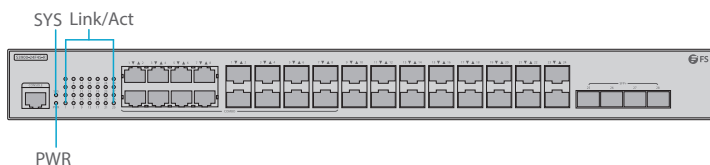

S3900-48T6S-R

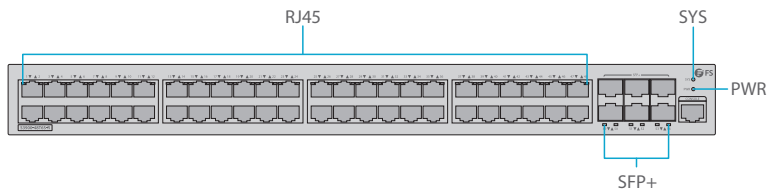

LEDs	Statut	Description
PWR	Vert	Le switch est sous tension.
SYS	Vert	Le système fonctionne correctement.
	Vert Clignotant	Le système a démarré normalement.
	Éteint	Le système ne fonctionne pas correctement.
Link/Act	Vert	Des données sont transmises ou reçues.
	Éteint	Aucune transmission de signal.
RJ45/SFP+	Vert	Des données sont transmises ou reçues.
	Éteint	Aucun dispositif n'est connecté au port correspondant.

Panneau Arrière

S3900-24T4S-R

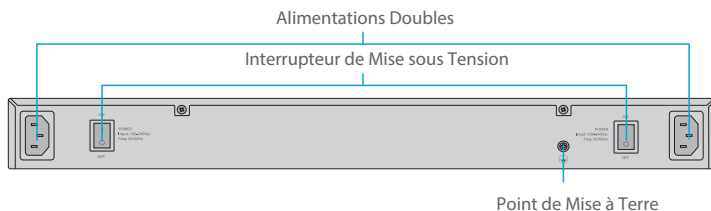

S3900-24F4S-R / S3900-48T6S-R

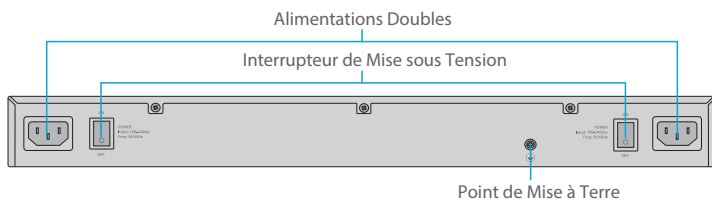

Button	Description
Interrupteur de mise sous tension	ON indique que le système est mis sous tension, OFF indique que le système est arrêté.

Exigences d'Installation

Seuls des professionnels sont autorisés à effectuer l'installation ou le remplacement du switch. Avant de commencer l'installation, assurez-vous que vous disposez des éléments suivants :

- Tournevis
- Bracelet anti-statique
- Câble Ethernet
- Autres dispositifs Ethernet
- Terminal de contrôle

Site de l'Installation :

- Ne pas installer l'appareil dans un endroit où la température ambiante dépasse 50°C.
- Le site d'installation doit être bien ventilé. Assurez-vous que la circulation d'air autour du switch soit suffisante.
- Assurez-vous que le switch est à niveau et stable pour éviter tout risque.
- Ne pas installer l'équipement dans un environnement poussiéreux.
- Le site d'installation doit être exempt de fuites d'eau et d'humidité.
- Assurez-vous que le rack et les plateformes de travail sont bien mis à terre.

Installation du Switch

Montage sur Support

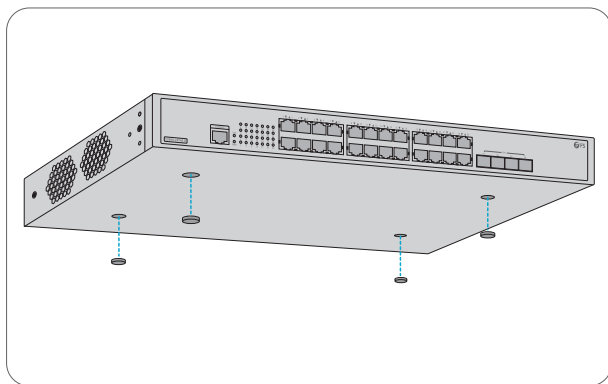

1. Fixez quatre coussins en caoutchouc à la base.
2. Placez le châssis sur le support.



NOTE: Ne pas placer d'objets pesant 4,5 kg ou plus sur le switch.

Montage sur Rack

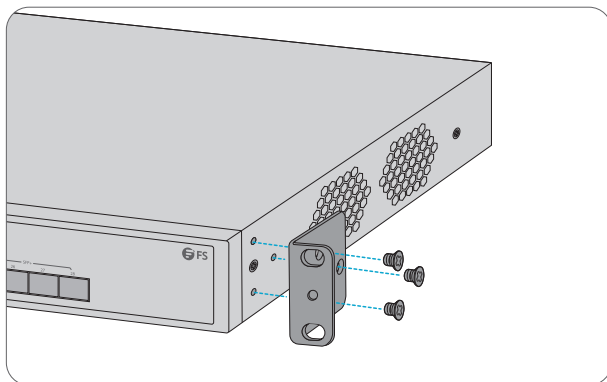

1. Fixez les supports de montage aux deux côtés du switch avec des vis M4.

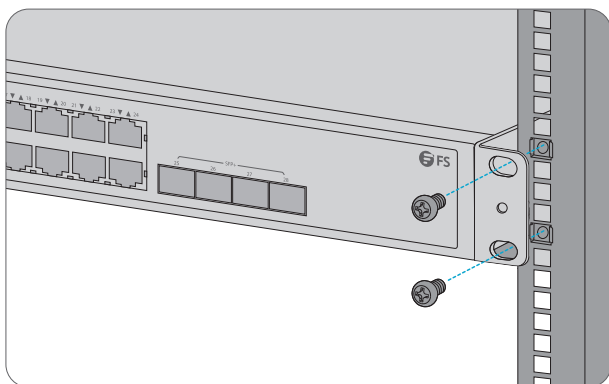

2. Fixez le switch au rack à l'aide de vis M6 et d'écrous à cage.

Mise à Terre du Switch

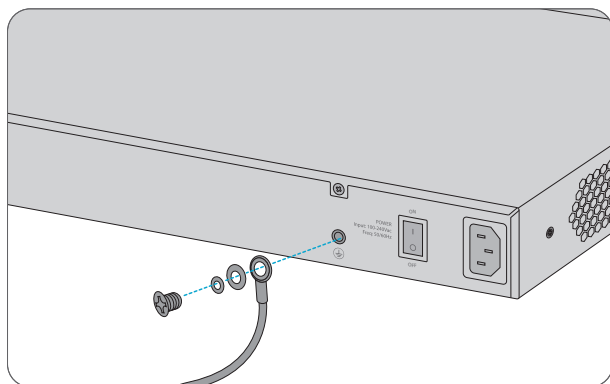

1. Connectez une extrémité du câble de mise à terre à une terre appropriée, telle que le rack sur lequel le switch est monté.
2. Fixez la fiche de mise à terre au point de mise à terre sur le panneau arrière du switch à l'aide des rondelles et des vis.



ATTENTION: La connexion de mise à terre ne doit pas être retirée avant que toutes les connexions d'alimentation n'aient été déconnectées.

Connexion de l'Alimentation

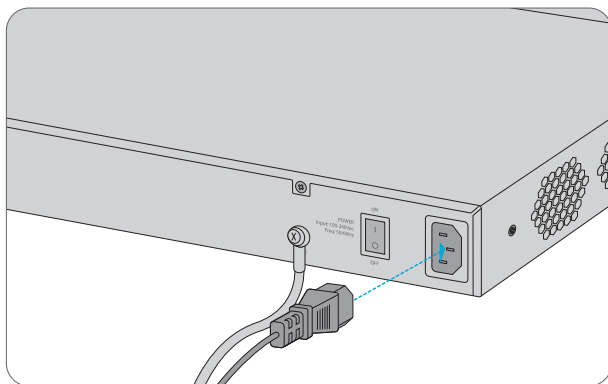

1. Branchez le câble d'alimentation CA dans le port d'alimentation situé à l'arrière du switch.
2. Connectez l'autre extrémité du câble d'alimentation à une source de courant alternatif.



AVERTISSEMENT: Ne pas installer le câble d'alimentation lorsque l'appareil est mis sous tension.

Connexion aux Ports RJ45

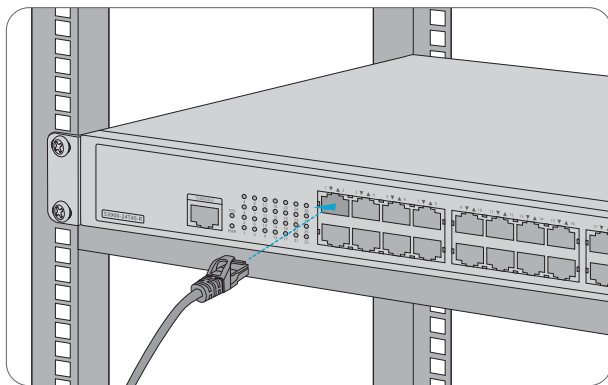

1. Connectez un câble Ethernet au port RJ45 d'un ordinateur, d'une imprimante, d'un stockage réseau ou d'autres périphériques réseau.
2. Connectez l'autre extrémité du câble Ethernet au port RJ45 du switch.

Connexion du SFP+

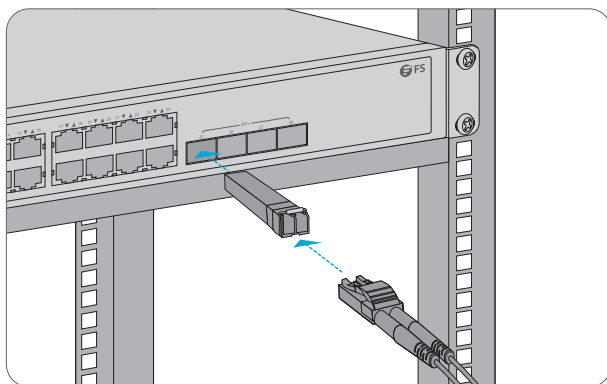

FR

1. Branchez le module SFP+/SFP compatible sur le port SFP+.
2. Connectez un câble de fibre optique au module optique. Puis connectez l'autre extrémité du câble à un autre appareil à fibre.



AVERTISSEMENT: Les faisceaux laser peuvent causer des lésions oculaires. Ne regardez pas dans les alésages des modules ou des fibres optiques sans protection oculaire.

Connexion du Port Console

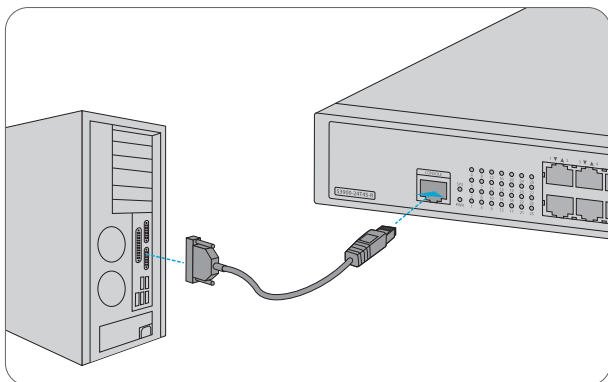

1. Insérez le connecteur RJ45 dans le port de console RJ45 situé à l'avant du switch.
2. Connectez le connecteur femelle DB9 du câble de la console au port série RS-232 de l'ordinateur.

Empilage des Switchs de la Série S3900

Les modèles S3900-24T4S-R et S3900-24F4S-R prennent en charge l'empilement hybride de 8 unités. Le S3900-48T6S-R prend en charge l'empilage de 6 unités entre modèles identiques. Les switchs peuvent être empilés physiquement à l'aide de câbles en fibre optique connectés à des modules SFP+, ou des Câbles à Attache Directe (DAC) 10G. Tous les ports SFP+ du switch peuvent être utilisés pour l'empilage physique.

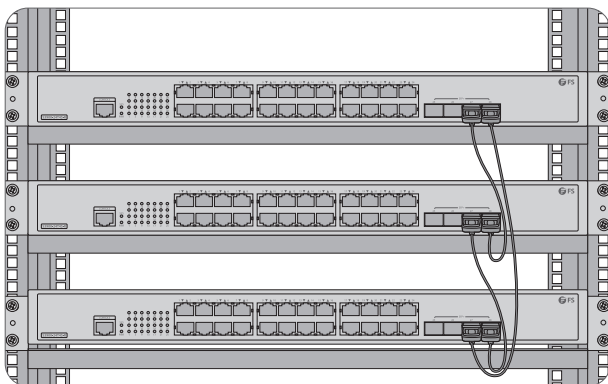

Configuration du Switch

Configuration du Switch à l'Aide de l'Interface Web

Étape 1 : Connectez votre ordinateur à n'importe quel port Ethernet du switch à l'aide du câble réseau.

Étape 2 : Définissez l'adresse IP de l'ordinateur sur **192.168.1.x**. ("x" est un nombre quelconque compris entre 2 et 254).

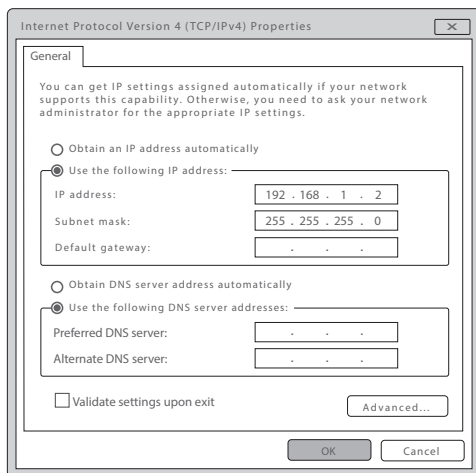

Étape 3 : Ouvrez un navigateur, tapez **http://192.168.1.1**, et entrez le nom d'utilisateur et le mot de passe par défaut, admin/admin

Étape 4 : Cliquez sur connexion pour afficher la page de configuration basée sur le Web.

Configuration du Switch à l'Aide du Port Console

Étape 1 : Connectez un ordinateur au port de console du switch à l'aide du câble de console fourni.

Étape 2 : Démarrez le logiciel HyperTerminal sur l'ordinateur.

Étape 3 : Réglez les paramètres de l'HyperTerminal : 115200 bits par seconde, 8 bits de données, pas de parité, 1 bit d'arrêt et pas de contrôle de flux.

Quick Connect

Protocol: Serial

The port may be manually entered or selected from the list.

Port: COM3

Baud rate: 115200

Data bits: 8

Parity: None

Stop bits: 1

Name of pipe:

Flow Control

DTR/DSR

RTS/CTS

XON/XOFF

Show quick connect on startup

Save session

Open in a tab

Connect Cancel

Dépannage

Le Port 1/10G ne Fonctionne pas

Si le port ne fonctionne pas avec des câbles et des modules compatibles, essayez de modifier le mode du port pour l'adapter ou de forcer la vitesse du port à 1G/10G.

Connexion à Distance du Switch sans Succès

1. Testez la connectivité du réseau par ping.
2. Si le réseau est accessible, essayez de redémarrer le switch.
3. Vérifiez si le service correspondant est activé.

Le Port est hors Service, l'Indicateur LED est Éteint.

1. Assurez-vous que les ports du switch sont en état de "no shutdown".
2. Vérifiez si le switch est capable de saisir les informations du DDM.
3. Vérifiez si les paramètres de vitesse du port sont corrects
4. Essayez de boucler le câble du switch.

Support et Autres Informations

- Télécharger <https://www.fs.com/fr/download.html>
- Centre d'Assistance https://www.fs.com/fr/service/help_center.html
- Contactez-Nous https://www.fs.com/fr/contact_us.html

Garantie des Produits

FS garantit à ses clients que tout dommage ou article défectueux dû à sa fabrication peut être retourné dans un délai de 30 jours à compter de la date de réception de la marchandise. Cela exclut tout article fabriqué sur mesure ou toute solution personnalisée.



Garantie : Les Switchs de la Série S3900 bénéficient d'une garantie limitée de 4 ans contre les défauts matériel ou de fabrication. Pour plus de détails sur la garantie, veuillez <https://www.fs.com/fr/policies/warranty.html>



Retour : Si vous souhaitez retourner un ou plusieurs articles, vous trouverez des informations sur les modalités de retour à l'adresse suivante https://www.fs.com/fr/policies/day_return_policy.html

Compliance Information

FCC

Note: This equipment has been tested and found to comply with the limits for a Class A digital device, pursuant to part 15 of the FCC Rules. These limits are designed to provide reasonable protection against harmful interference when the equipment is operated in a commercial environment. This equipment generates, uses, and can radiate radio frequency energy and, if not installed and used in accordance with the instruction manual, may cause harmful interference to radio communications. Operation of this equipment in a residential area is likely to cause harmful interference in which case the user will be required to correct the interference at his own expense.

This device complies with part 15 of the FCC Rules. Operation is subject to the following two conditions: (1) This device may not cause harmful interference, and (2) this device must accept any interference received, including interference that may cause undesired operation.

CAUTION:

Any changes or modifications not expressly approved by the grantee of this device could void the user's authority to operate the equipment.

Responsible party (only for FCC matter)

FS.COM Inc.

380 Centerpoint Blvd, New Castle, DE 19720, United States

<https://www.fs.com>

CE

FS.COM GmbH hereby declares that this device is in compliance with the Directive 2014/30/EU and 2014/35/EU. A copy of the EU Declaration of Conformity is available at www.fs.com/company/quality_control.html

Die FS.COM GmbH erklärt hiermit, dass dieses Gerät mit der Richtlinie 2014/30/EU und 2014/35/EU konform ist. Eine Kopie der EU-Konformitätserklärung finden Sie unter www.fs.com/de/company/quality_control.html.

FS.COM GmbH déclare par la présente que cet appareil est conforme à la Directive 2014/30/UE et 2014/35/UE. Une copie de la Déclaration UE de Conformité est disponible sur https://www.fs.com/fr/company/quality_control.html

FS.COM LIMITED
24F, Infore Center, No.19, Haitian 2nd Rd,
Binhai Community, Yuehai Street, Nanshan
District, Shenzhen City

FS.COM GmbH
NOVA Gewerbepark Building 7, Am
Gfild 7, 85375 Neufahrn bei Munich, Germany



5654

Q.C. PASSED

Copyright © 2021 FS.COM All Rights Reserved.