

# 10G DWDM SFP+ 100GHz 1528.77nm-1563.86nm 80KM DOM Transceiver

DWDM-SFP10G-80



## Application

- 10GBASE-ZR/ZW
- 10G Fiber Channel
- OBSAI rates 6.144 Gb/s, 3.072 Gb/s, 1.536 Gb/s, 0.768Gb/s
- CPRI rates 9.830 Gb/s, 7.373Gb/s, 6.144 Gb/s, 4.915 Gb/s, 2.458 Gb/s, 1.229 Gb/s, 0.614Gb/s
- Other optical links

## Features

- Available in all C-Band Wavelengths on the 100GHz DWDM ITU Grid
- Duplex LC Connector
- Temperature-Stabilized DWDM EML Transmitter
- Power Dissipation (0°C to 70°C) < 1.5W
- Power Dissipation (-40°C to 85°C) < 1.8W
- Dispersion tolerance : +/-1600ps/nm
- Hot-Pluggable SFP+ Footprint
- Compliant with SFF-8431 MSA and SFF-8432 MSA
- Built-in digital diagnostic functions, including optical power monitoring
- Commercial temperature range: 0°C to 70°C

## Description

The DWDM-SFP10G-80 series single mode transceiver is small form factor pluggable module for duplex optical data communications. This module is designed to deploy in the DWDM networking equipment in metropolitan access and core networks and operates at a nominal DWDM wavelength from 1528nm to 1566nm as specified by the ITU-T. They are complaint with the SFF-8431 MSA and SFF-8432 MSA .

## Product Specifications

### I.General Specifications

Parameter	Symbol	Min	Typ.	Max	Unit	Ref.
<b>Module Form Factor</b>	BR	9.95		10.5	Gb/s	1
<b>Number of Lanes</b>	BER			10 <sup>-12</sup>		2
<b>Maximum Aggregate Data Rate</b>	L <sub>max</sub>		80		km	

#### Notes:

1. 10GBASE-ZR, 10GBASE-ZW, 1200-SM-LL-L 10GFC.
2. Tested with a PRBS 2<sup>31</sup>-1 test pattern.

### II. Absolute Maximum Ratings

Parameter	Symbol	Min	Typ.	Max	Unit
<b>Storage Temperature</b>	T <sub>s</sub>	-40		85	°C
<b>Supply Voltage</b>	V <sub>cc</sub>	-0.5		3.6	V
<b>Operating Relative Humidity</b>				95	%

### III. Electrical Characteristics (TOP= 0 to 70 ° C, VCC = 3.14 to 3.46 Volts)

Parameter	Symbol	Min	Typ.	Max	Unit	Notes
<b>Power Supply Voltage</b>	Vcc	3.15	3.3	3.45	V	
<b>Power Supply Current</b>	I <sub>cc</sub> (0°C to 70°C)		350	455	mA	
	I <sub>cc</sub> (-40°C to 85°C)		350	545	mA	
<b>Date Rate</b>	DR	0.6		11.3	Gbps	Date Rate
<b>Transmitter</b>						
<b>TX_Dis</b>	Disable	2		V <sub>cc</sub> +0.3	V	
	Enable	0		0.8		
<b>TX_FAULT</b>	Fault	2		V <sub>cc</sub> +0.3	V	
	Normal	0		0.5		
<b>CML Inputs (Differential)</b>	V <sub>in</sub>	250		1000	mVpp	AC coupled input
<b>Input Impedance (Differential)</b>	Z <sub>in</sub>	85	100	115	ohm	R <sub>in</sub> > 100 kohm @ DC
<b>Receiver</b>						
<b>CML Outputs (Differential)</b>	V <sub>out</sub>	350		700	mVpp	AC coupled output
<b>RX_LOS</b>	LOS	2		V <sub>cc</sub> +0.3	V	
	Normal	0		0.8	V	
<b>Output Impedance (Differential)</b>	Z <sub>out</sub>	85	100	115	ohm	
<b>MOD_DEF (0:2)</b>	VoH	2.5			V	With Serial ID
	VoL	0		0.5	V	

#### IV. Optical Characteristics (TOP = 0 to 70 °C, VCC = 3.14 to 3.46 V)

Parameter	Symbol	Min	Typ.	Max	Unit
<b>Data Rate</b>		0.6		11.3	Gbps
<b>Transmitter</b>					
<b>Side Mode Suppression Ratio</b>	SMSR	30			dB
<b>Center Wavelength Spacing</b>			100		GHz
			0.8		nm
<b>Average Output Power</b>	Pout	0		4	dBm
<b>Average Launch Power (Tx: OFF)</b>	Poff			-30	dBm
<b>Extinction Ratio</b>	ER	3.5			dB
<b>Transmitter Dispersion Penalty @800ps/nm</b>	TDP			2	dB
<b>Pout@TX Disable Asserted</b>	Pout			-45	dBm
<b>Relative Intensity Noise</b>	RIN			-128	dB/Hz
<b>TX Jitter</b>	TXj		Per 802.3ae requirements		
<b>Receiver</b>					
<b>Receiver Sensitivity</b>	Pmin			-23	dBm
<b>Receiver Overload</b>	Pmax	-1			dBm
<b>LOS De-Assert</b>	LOSD			-17	dBm
<b>LOS Assert</b>	LOSA	-29			dBm
<b>LOS Hysteresis</b>		1			dB

#### Notes:

1. Output is coupled into a 9/125μm single-mode fiber.
2. Minimum average optical power measured at the BER less than 1E-12. The measurepattern is PRBS 2<sup>31</sup>-1.
3. CML logic, internally AC coupled.

## V. Wavelength Table

Channel	Frequency (THz)	Center Wavelength (nm)	Channel	Frequency (THz)	Center Wavelength (nm)
17	191.7	1563.86	40	194	1545.32
18	191.8	1563.05	41	194.1	1544.53
19	191.9	1562.23	42	194.2	1543.73
20	192	1561.41	43	194.3	1542.94
21	192.1	1560.61	44	194.4	1542.14
22	192.2	1559.79	45	194.5	1541.35
23	192.3	1558.98	46	194.6	1540.56
24	192.4	1558.17	47	194.7	1539.77
25	192.5	1557.36	48	194.8	1538.98
26	192.6	1556.55	49	194.9	1538.19
27	192.7	1555.75	50	195	1537.4
28	192.8	1554.94	51	195.1	1536.61
29	192.9	1554.13	52	195.2	1535.82
30	193	1553.33	53	195.3	1535.04
31	193.1	1552.52	54	195.4	1534.25
32	193.2	1551.72	55	195.5	1533.47
33	193.3	1550.92	56	195.6	1532.68
34	193.4	1550.12	57	195.7	1531.9
35	193.5	1549.32	58	195.8	1531.12
36	193.6	1548.51	59	195.9	1530.33
37	193.7	1547.72	60	196	1529.55
38	193.8	1546.92	61	196.1	1528.77
39	193.9	1546.12			

## VI. Pin Description

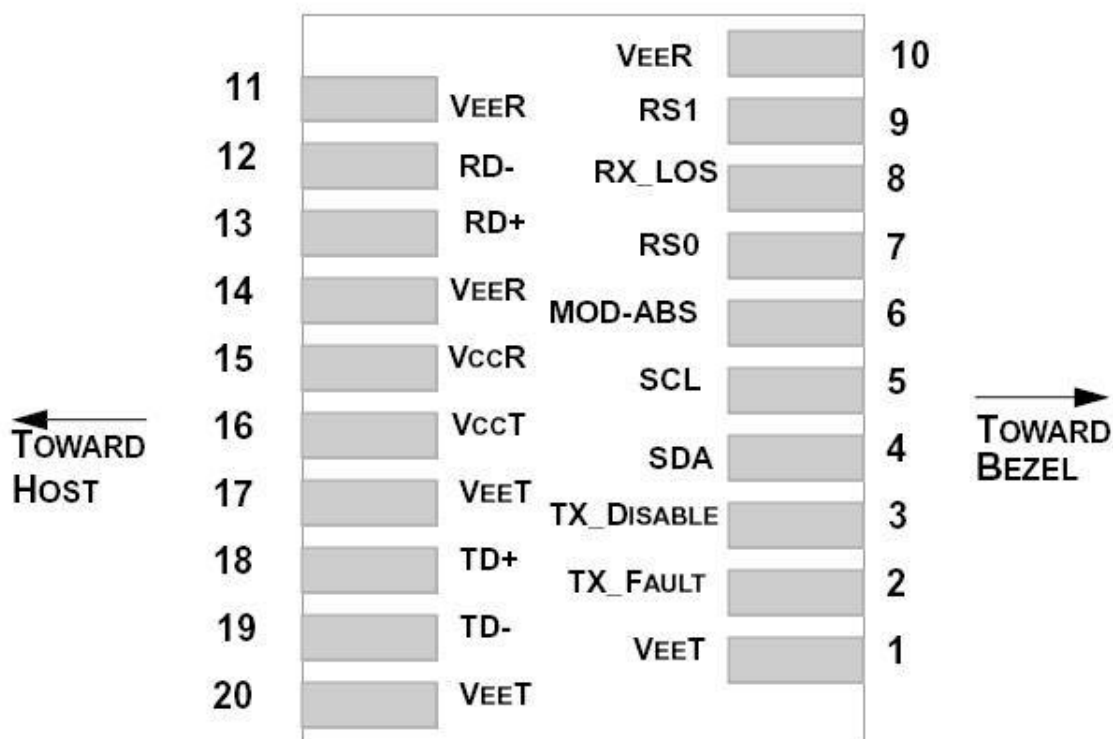

Pin Num.	Name	Function	Plug Seq.	Notes
1	VeeT	Transmitter Ground	1	Note 5
2	TX Fault	Transmitter Fault Indication	3	Note 1
3	TX Disable	Transmitter Disable	3	Note 2, Module disables on high or open
4	SDA	Module Definition 2	3	Note 3, Data line for Serial ID.
5	SCL	Module Definition 1	3	Note 3, Clock line for Serial ID.
6	MOD-ABS	Module Definition 0	3	Note 3
7	RS0	RX Rate Select (LVTTL).	3	Rate Select 0, optionally controls SFP+ module receiver. This pin is pulled low to VeeT with a >30K resistor

8	LOS	Loss of Signal	3	Note 4
9	RS1	TX Rate Select (LVTTTL).	1	Rate Select 1, optionally controls SFP+ module transmitter. This pin is pulled low to VeeT with a >30K resistor.
10	VeeR	Receiver Ground	1	Note 5
11	VeeR	Receiver Ground	1	Note 5
12	RD	Inv. Received Data Out	3	Note 6
13	RD+	Received Data Out	3	Note 7
14	VeeR	Receiver Ground	1	Note 5
15	VccR	Receiver Power	2	3.3 ± 5%, Note 7
16	VccT	Transmitter Power	2	3.3 ± 5%, Note 7
17	VeeT	Transmitter Ground	1	Note 5
18	TD+	Transmit Data In	3	Note 8
19	TD-	Inv. Transmit Data In	3	Note 8
20	VeeT	Transmitter Ground	1	Note 5

#### Notes:

1. TX Fault is an open collector/drain output, which should be pulled up with a 4.7K - 10K resistor on the host board. Pull up voltage between 2.0V and VccT, R+0.3V. When high, output indicates a laser fault of some kind. Low indicates normal operation. In the low state, the output will be pulled to < 0.8V.
2. TX disable is an input that is used to shut down the transmitter optical output. It is pulled up within the module with a 4.7-10 K\_x0002\_resistor. Its states are: Low (0 - 0.8V): Transmitter on(>0.8, < 2.0V): Undefined High (2.0 - 3.465V): Transmitter Disabled Open: Transmitter Disabled
3. Module absent, connected to VEET or VEER in the module.

4. LOS (Loss of Signal) is an open collector/drain output, which should be pulled up with a 4.7K–10K resistor. Pull up voltage between 2.0V and  $V_{CC}$ ,  $R+0.3V$ . When high, this output indicates the received optical power is below the worst-case receiver sensitivity (as defined by the standard in use). Low indicates normal operation. In the low state, the output will be pulled to  $< 0.8V$ .
5. VeeR and VeeT may be internally connected within the SFP+ module.
6. RD-/+: These are the differential receiver outputs. They are AC coupled 100 differential lines which should be terminated with 100(differential) at the user SERDES. The AC coupling is done inside the module and is thus not required on the host board.
7. VccR and VccT are the receiver and transmitter power supplies. They are defined as  $3.3V \pm 5\%$  at the SFP+ connector pin. Maximum supply current is 300mA. Inductors with DC resistance of less than 1 ohm should be used in order to maintain the required voltage at the SFP+ input pin with 3.3V supply voltage. When the recommended supply-filtering network is used, hot plugging of the SFP+ transceiver module will result in an inrush current of no more than 30mA greater than the steady state value. VccR and VccT may be internally connected within the SFP+ transceiver module.
8. TD-/+: These are the differential transmitter inputs. They are AC-coupled, differential lines with 100 differential termination inside the module. The AC coupling is done inside the module and is thus not required on the host board.



## VII. Mechanical Specifications

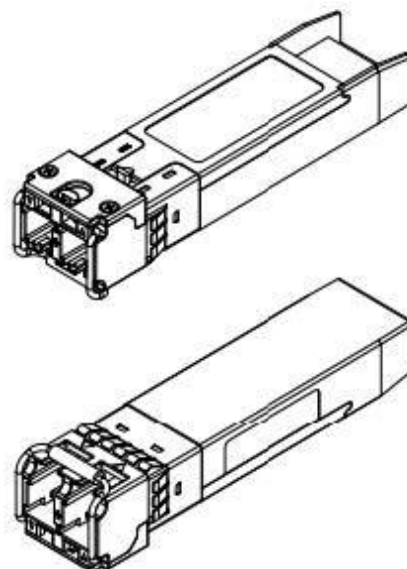
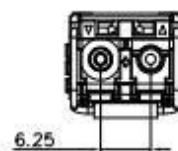
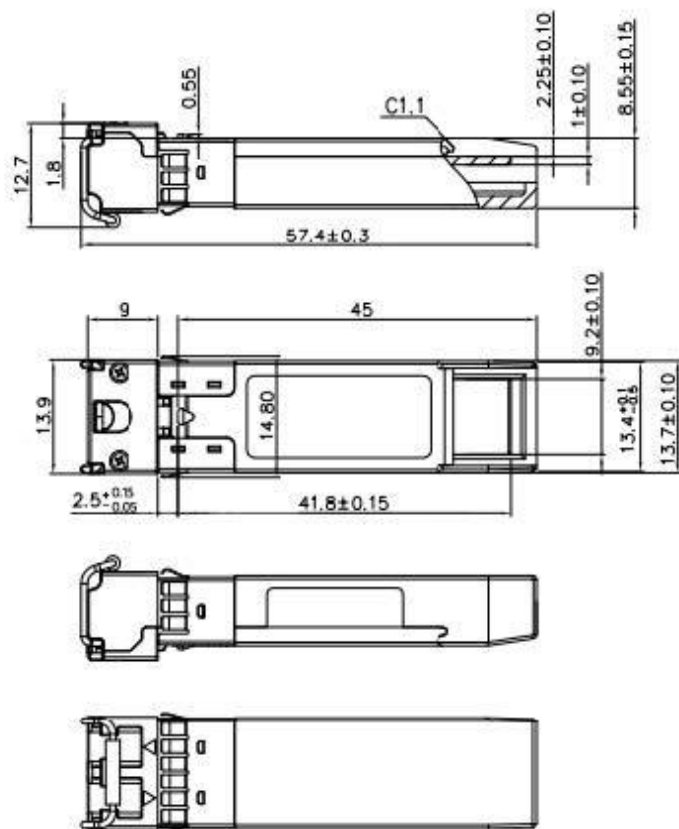

Unremarked tolerances  $\pm 0.2\text{mm}$

## Test Center

FS.COM transceivers are tested to ensure connectivity and compatibility in our test center before shipped out. FS.COM test center is supported by a variety of mainstream original brand switches and groups of professional staff, helping our customers make the most efficient use of our products in their systems, network designs and deployments.

The original switches could be found nowhere but at FS.COM test center, eg: Juniper MX960 & EX 4300 series, Cisco Nexus 9396PX & Cisco ASR 9000 Series, HP 5900 Series & HP 5406R ZL2 V3(J9996A), Arista 7050S-64, Brocade ICX7750-26Q & ICX6610-48, Avaya VSP 7000 MDA 2, etc.



Cisco ASR 9000 Series(A9K-MPA-1X40GE)



ARISTA 7050S-64(DCS-7050S-64)



Juniper MX960



Brocade ICX 7750-26Q



Extreme Networks X670V VIM-40G4X



Mellanox M3601Q



Dell N4032F



HP 5406R ZL2 V3(J9996A)



AVAYA 7024XLS(7002QQ-MDA)

## Test Assured Program

FS.COM truly understands the value of compatibility and interoperability to each optics. Every module FS.COM provides must run through programming and an extensive series of platform diagnostic tests to prove its performance and compatibility. In our test center, we care of every detail from staff to facilities—professionally trained staff, advanced test facilities and comprehensive original-brand switches, to ensure our customers to receive the optics with superior quality.



Our smart data system allows effective product management and quality control according to the unique serial number, properly tracking the order, shipment and every part.



With a comprehensive line of original-brand switches, we can recreate an environment and test each optics in practical application to ensure quality and distance.

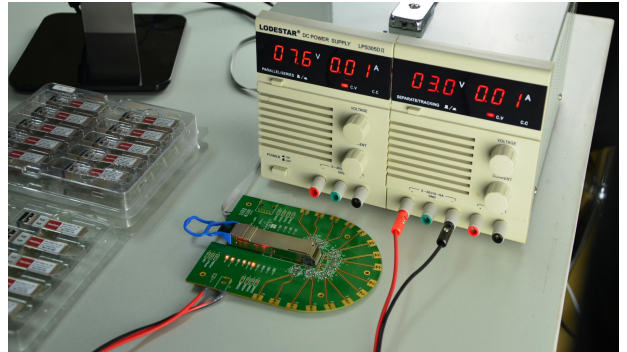

Our in-house coding facility programs all of our parts to standard OEM specs for compatibility on all major vendors and systems such as Cisco, Juniper, Brocade, HP, Dell, Arista and so on.



The last test assured step to ensure our products to be shipped with perfect package.

## Excellent Quality Control System

FS innovated a self-developed automated and integrated test system, and also equipped with complete sets of advanced testing equipment to ensure modules quality and high performance.



### Performance Testing

One-Click operation, including centre-wavelength, extinction ratio, optical eye diagram, TX power, receiver sensitivity, DDM etc.

### Environmental Testing

Low temp test, storage in 85° C and -40° C for 12 hours. ESD test,  $\pm 8$  and  $\pm 15$  kV discharges as per GR-78-CORE. Connector durability - pull test, min of 10 connections, no more than 30% pullouts.



### Compatibility and Connectivity Testing

Equipped with a variety of mainstream original brand switches, like Cisco, Juniper, Arista, HPE etc. Each transceiver will be tested before delivery.

## Order Information

Part Number	Description
DWDM-SFP10G-40	SFP+, 10GBase-ER, DWDM 100GHz 1528.77nm-1563.86nm, SMF, 40km, LC, DOM
DWDM-SFP10G-80	SFP+, 10GBase-ZR, DWDM 100GHz 1528.77nm-1563.86nm, SMF, 80km, LC, DOM
DWDM-SFP10G-40	SFP+, 10GBase-ER, DWDM 50GHz 1528.77nm-1563.86nm, SMF, 40km, LC, DOM
DWDM-SFP10G-80	SFP+, 10GBase-ZR, DWDM 50GHz 1528.77nm-1563.86nm, SMF, 80km, LC, DOM

**Note:**

10G DWDM SFP+ transceiver module is individually tested on corresponding equipment such as Cisco, Arista, Juniper, Dell, Brocade and other brands, and passes the monitoring of FS.COM intelligent quality control system.



 <https://www.fs.com>



The information in this document is subject to change without notice. FS has made all efforts to ensure the accuracy of the information, but all information in this document does not constitute any kind of warranty.