

10G SFP+ 1550nm 100km DOM Transceiver

SFP-10GZRC-55



Application

- 10G Ethernet ZR and 10G Fibre Channel
- OTN G.709 OTU1e/2/2e FEC bit rates
- 8.5Gb/s Fibre Channel

Features

- Hot-pluggable SFP+ footprint
- Supports 8.5 and 9.95 to 11.3 Gb/s
- 100km link length
- 0/70° C case temperature range
- Cooled 1550nm EML laser
- Limiting electrical interface receiver
- Duplex LC connector
- Built-in digital diagnostic functions
- RoHS-6 compliant (lead-free)

Description

10GBASE-ZR SFP+ transceivers are Enhanced Small Form Factor Pluggable SFP+ transceivers designed for use in 10-Gigabit multi-rate links up to 100km of G.652 single mode fiber. They support 10G Ethernet ZR and 10G Fibre Channel.

Digital diagnostics functions are available via a 2-wire serial interface. The optical transceiver is compliant per the RoHS Directive 2011/65/EU.

Product Specifications

I. General Specifications

Data Rate Specifications	Symbol	Min	Typ.	Max	Units	Ref.
Bit Rate	BR	8.5		11.3168	Gb/s	1
Max. Supported Link Length	LMAX			100	km	2

Notes:

1. Tested with a 231 –1 PRBS pattern at the BER defined in Table IV.
2. Over G.652 single mode fiber.

II. Absolute Maximum Ratings

Parameter	Symbol	Min	Typ.	Max	Unit	Ref.
Maximum Supply Voltage	Vcc	-0.5		4.0	V	
Storage Temperature	Ts	-40		+85	° C	
Case Operating Temperature	Top	0			° C	
Relative Humidity	RH	0		85	%	1
Receiver Optical Damage Threshold	RxDamage	5			dBm	

Note:

1. Non-condensing.

III. Electrical Characteristics

Parameter	Symbol	Min	Typ.	Max	Unit	Ref.
Supply Voltage	V _{cc}	3.14	3.30	3.47	V	
Power Consumption	P _{diss}			1.8	W	1
Transmitter (Tx)						
Input differential impedance	R _{in}	-80	100	120	Ω	
Differential data input swing	V _{in,pp}	180		700	mV	2
Transmit Disable Voltage	VD	2.0		V _{cc}	V	3
Transmit Enable Voltage	VEN	0		0.8	V	
Receiver (Rx)						
Output differential impedance	R _{out}	80	100	120	Ω	
Differential data output swing	V _{out,pp}	300		850	mV	
Output rise time and fall time	T _r , T _f	30			ps	4
LOS asserted	V _{LOS A}	V _{cc} -0.8		V _{cc}	V	4
LOS de-asserted	V _{LOS D}	0		0.8	v	4
Power Supply Noise Tolerance	V _{ccT/V_{ccR}}		Per SFF-8431 Rev 4.1		mV _{pp}	5

Notes:

1. 70°C case temperature and beginning of life
2. Internally AC coupled.
3. 20°C–80%. Measured with Module Compliance Test Board and OMA test pattern. Use of four 1's and four 0's sequence in the PRBS 9 is an acceptable alternative. SFF-8431 Rev 4.1.
4. LOS is an open collector output. Should be pulled up with 4.7kΩ–10kΩ on the host board. Normal operation is logic 0; loss of signal is logic 1. Hit ratio = 5 x 10E-5.
5. See Section 2.8.3 of SFF-8431 Rev 4.1.

IV. Optical Characteristics (TOP = 0 to 70°C, VCC = 3.14 to 3.46 Volts)

Parameter	Symbol	Min	Typ.	Max	Unit	Ref.
Transmitter (Tx)						
Average Launch Power	PAVE	0		4	dBm	
Optical Wavelength	λ	1530	1550	1565	nm	
Side-Mode Suppression Ratio	SMSR	30			dB	
Optical Extinction Ratio	ER	8.2			dB	
Average launch power when Tx is OFF	POFF			-30	dBm	
Relative Intensity Noise	RIN			-128	dB/Hz	
Receiver (Rx)						
Optical Center Wavelength	λ_C	1260		1620	nm	
Sensitivity (0km)	Bit Rate (Gb/s)	BER				
	8.5,9.95-10.7	<10 ⁻¹²	RSENS1		-24	dBm, 1,2
	11.1	<10 ⁻¹²	RSENS2		-23	dBm, 1
		<10 ⁻¹²	RSENS3		-27	dBm, 1
11.3	<10 ⁻⁴	RSENS4		-27	dBm, 1	
Sensitivity (80km)	8.5,9.95-10.7	<10 ⁻¹²	RSENS5		-22	dBm, 1,2,3
	11.1	<10 ⁻⁴	RSENS6		-25	dBm, 1,2
Overload(Average Power)	PAVE	-7			dBm	5
Receiver Reflectance	Rrx			-27	dB	
LOS De-Assert	LOSD			-28	dBm	
LOS Assert	LOSA	-3.7		-30	dBm	
LOS Hysteresis	LOSH	0.5		-26	dB	

Notes:

1. Measured with worst ER=9 dB; PRBS 231 – 1.
2. For 10GEthernet application, -24dBm is equivalent to an OMA of -22.09dBm for an ER = 9 dB.
3. The receiver sensitivity over fiber may vary depending on the host's clock and data recovery model.

V. Digital Diagnostic Specifications

10GBASE-ZRC SFP+ transceivers can be used in host systems that require either internally or externally calibrated digital diagnostics.

Parameter	Symbol	Units	Min	Max	Accuracy	Ref.
Transceiver temperature	ΔDD_{Temp}	°C	-5	+70	$\pm 3^{\circ}C$	1
Transceiver supply voltage	$\Delta DD_{Voltage}$	V	2.8	4.0	$\pm 5\%$	
Transmitter bias current	ΔDD_{Bias}	mA	0	127	$\pm 10\%$	2
Transmitter output power	$\Delta DD_{TxPower}$	dBm	-1	+5	$\pm 3.0dB$	
Receiver average optical input power	$\Delta DD_{Rx-Power}$	dBm	-28	-5	$\pm 3.0dB$	

Notes:

1. Internally measured
2. The accuracy of the Tx bias current is 10% of the actual current from the laser driver to the laser

VI. Pin Description

Pin	Symbol	Name/Description	Ref.
1	VEET	Transmitter Ground	1
2	TFAULT	Transmitter Fault	2
3	TDIS	Transmitter Disable. Laser output disabled on high or open.	3
4	SDA	2-wire Serial Interface Data Line	2
5	SCL	2-wire Serial Interface Clock Line	2
6	MOD_ABS	Module Absent. Grounded within the module	2
7	RS0	Rate Select 0.	4
8	RX_LOS	Loss of Signal indication. Logic 0 indicates normal operation.	5
9	RS1	Rate Select 1.	4
10	VEER	Receiver Ground	1
11	VEER	Receiver Ground	1
12	RD-	Receiver Inverted DATA out. AC Coupled.	
13	RD+	Receiver Non-inverted DATA out. AC Coupled.	
14	VEER	Receiver Ground	1
15	VCCR	Receiver Power Supply	
16	VCCT	Transmitter Power Supply	
17	VEET	Transmitter Ground	1
18	TD+	Transmitter Non-Inverted DATA in. AC Coupled.	
19	TD-	Transmitter Inverted DATA in. AC Coupled.	
20	VEET	Transmitter Ground	1

Notes:

1. Circuit ground is internally isolated from chassis ground.
2. TFAULT is an open collector/drain output, which should be pulled up with a 4.7k -10k Ohms resistor on the host board if intended for use. Pull up voltage should be between 2.0V to $V_{cc} + 0.3V$. A high output indicates a transmitter fault caused by either the TX bias current or the TX output power exceeding the preset alarm thresholds. A low output indicates normal operation. In the low state, the output is pulled to <math><0.8V</math>.
3. Laser output disabled on TDIS >2.0V or open, enabled on TDIS <0.8V.
4. Internally pulled down per SFF-8431 Rev 2.0. See Sec. X for the logic table to use for the internal CDRs locking modes.
5. LOS is open collector output. Should be pulled up with 4.7k Ω -10k Ω on host board to a voltage between 2.0V and 3.6V. Logic 0 indicates normal operation; logic 1 indicates loss of signal.

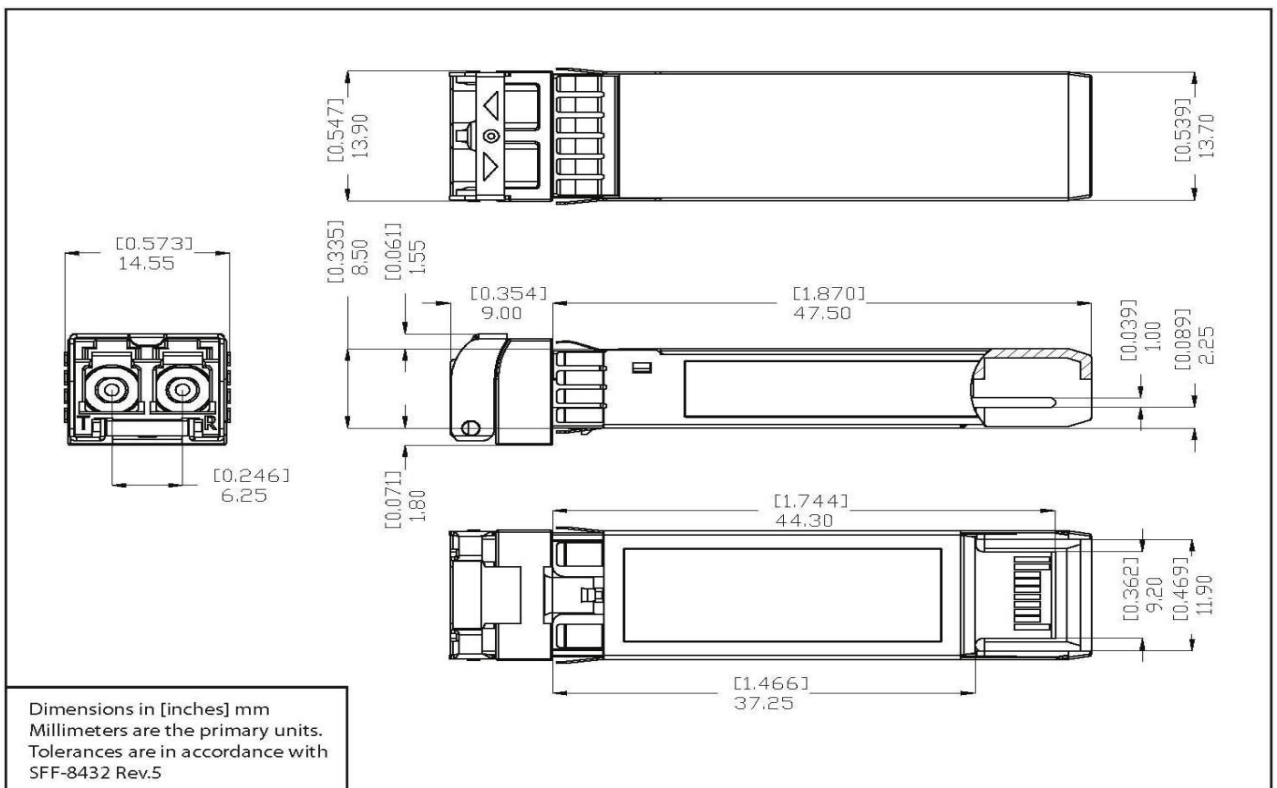
VII. Mechanical Specifications**Note:**

The option of the label on the top side of the transceiver is not recommended.

VIII. Host Board SFP+ Connector Recommendations

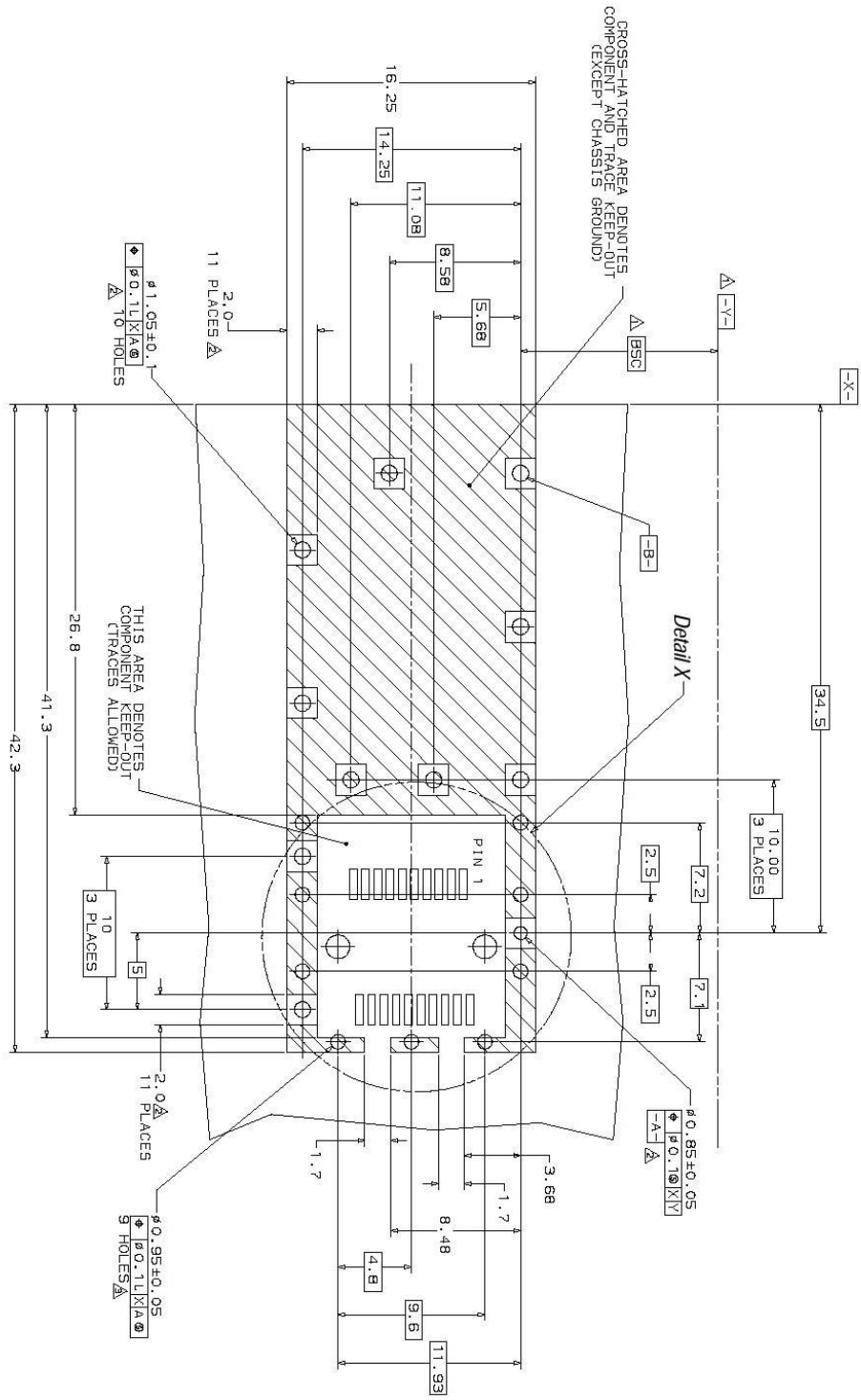

- Datum and Basic Dimension Established by Customer
- Pads and Vias are Chassis Ground, 11 Places
- Through Holes are Unplated

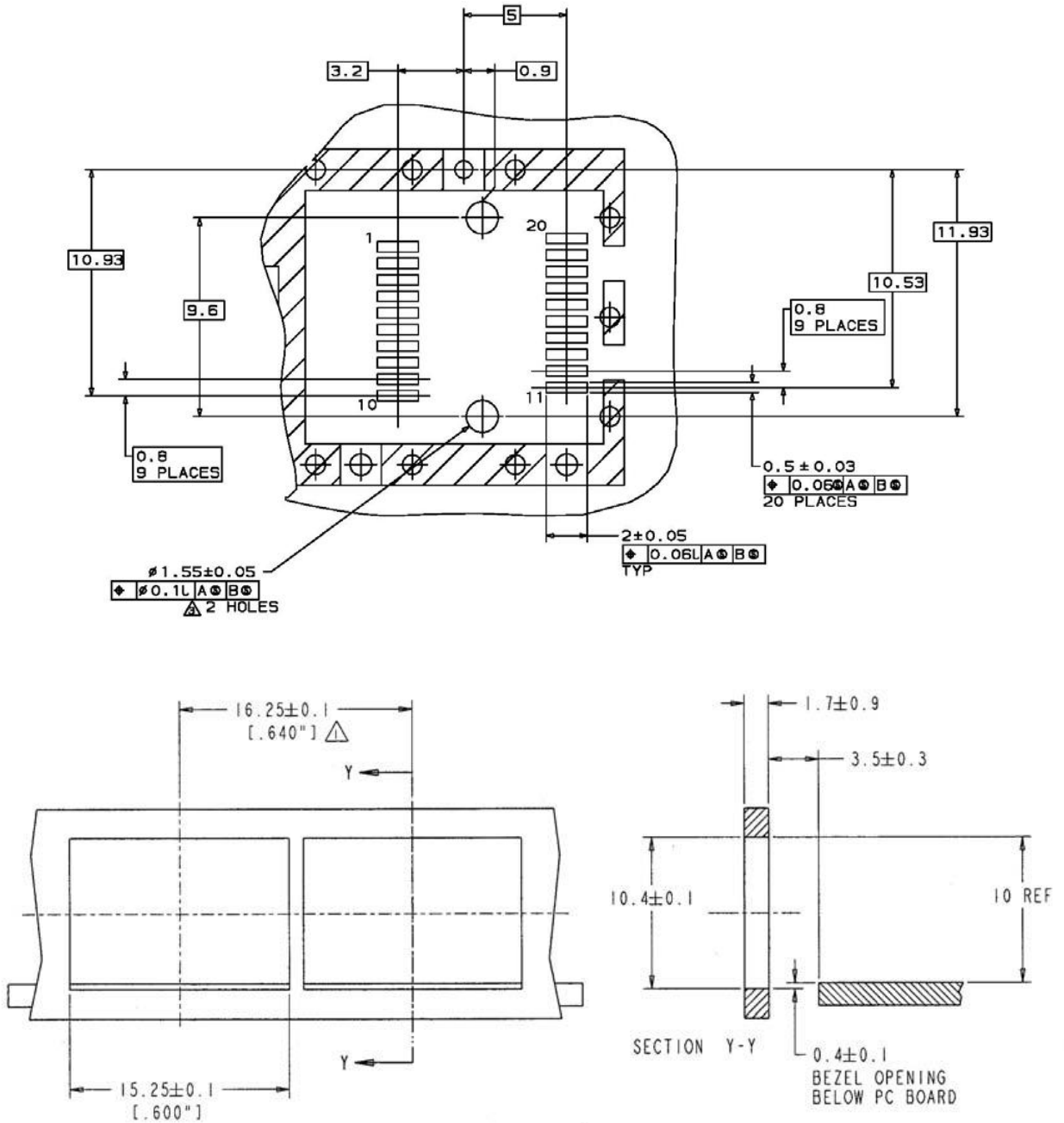

NOTES:

- △ MINIMUM PITCH ILLUSTRATED, ENGLISH DIMENSIONS ARE FOR REFERENCE ONLY
- 2. NOT RECOMMENDED FOR PCI EXPANSION CARD APPLICATIONS

Test Center

FS.COM transceivers are tested to ensure connectivity and compatibility in our test center before shipped out. FS.COM test center is supported by a variety of mainstream original brand switches and groups of professional staff, helping our customers make the most efficient use of our products in their systems, network designs and deployments.

The original switches could be found nowhere but at FS.COM test center, eg: Juniper MX960 & EX 4300 series, Cisco Nexus 9396PX & Cisco ASR 9000 Series, HP 5900 Series & HP 5406R ZL2 V3(J9996A), Arista 7050S-64, Brocade ICX7750-26Q & ICX6610-48, Avaya VSP 7000 MDA 2, etc.



Cisco ASR 9000 Series(A9K-MPA-1X40GE)



ARISTA 7050S-64(DCS-7050S-64)

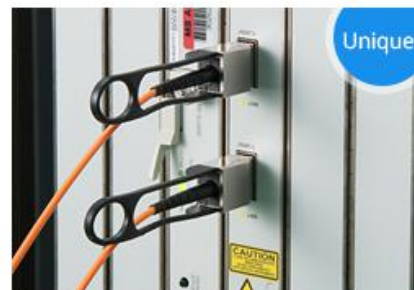

Juniper MX960



Brocade ICX 7750-26Q



Extreme Networks X670V VIM-40G4X



Mellanox M3601Q



Dell N4032F



HP 5406R ZL2 V3(J9996A)



AVAYA 7024XLS(7002QQ-MDA)

Test Assured Program

FS.COM truly understands the value of compatibility and interoperability to each optics. Every module FS.COM provides must run through programming and an extensive series of platform diagnostic tests to prove its performance and compatibility. In our test center, we care of every detail from staff to facilities—professionally trained staff, advanced test facilities and comprehensive original-brand switches, to ensure our customers to receive the optics with superior quality.



Our smart data system allows effective product management and quality control according to the unique serial number, properly tracing the order, shipment and every part.

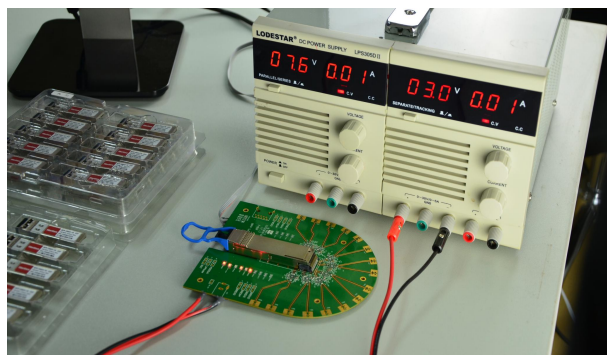

Our in-house coding facility programs all of our parts to standard OEM specs for compatibility on all major vendors and systems such as Cisco, Juniper, Brocade, HP, Dell, Arista and so on.



With a comprehensive line of original-brand switches, we can recreate an environment and test each optics in practical application to ensure quality and distance.



The last test assured step to ensure our products to be shipped with perfect package.

Excellent Quality Control System

FS innovated a self-developed automated and integrated test system, and also equipped with complete sets of advanced testing equipment to ensure modules quality and high performance.



Performance Testing

One-Click operation, including centre-wavelength, extinction ratio, optical eye diagram, TX power, receiver sensitivity, DDM etc.

Environmental Testing

Low temp test, storage in 85° C and -40° C for 12 hours. ESD test, ± 8 and ± 15 kV discharges as per GR-78-CORE. Connector durability - pull test, min of 10 connections, no more than 30% pullouts.



Compatibility and Connectivity Testing

Equipped with a variety of mainstream original brand switches, like Cisco, Juniper, Arista, HPE etc. Each transceiver will be tested before delivery.

Order Information

Part Number	Description
SFP-10GSR-85	10GBASE-SR SFP+ 850nm 300m DOM Transceiver
SFP-10GLRM-31	10G SFP+ 1310nm 2km DOM Transceiver
SFP-10GLR-31	10GBASE-LR SFP+ 1310nm 10km DOM Transceiver
SFP-10GER-55	10GBASE-ER SFP+ 1550nm 40km DOM Transceiver
SFP-10GZR-55	10GBASE-ZR SFP+ 1550nm 80km DOM Transceiver
SFP-10GZRC-55	10G SFP+ 1550nm 100km DOM Transceiver
SFP-10GSR-85	Dual-Rate 1000BASE-SX and 10GBASE-SR SFP+ 850nm 300m DOM Transceiver
SFP-10GLR-31	Dual-Rate 1000BASE-LX and 10GBASE-LR SFP+ 1310nm 10km DOM Transceiver

Note:

1.10G SFP+ transceiver module is individually tested on corresponding equipment such as Cisco, Arista, Juniper, Dell, Brocade and other brands, and passes the monitoring of FS.COM intelligent quality control system.



 <https://www.fs.com>



The information in this document is subject to change without notice. FS has made all efforts to ensure the accuracy of the information, but all information in this document does not constitute any kind of warranty.