

8ch Dual Fiber 1470-1610nm CWDM Mux Demux + Monitor, Expansion and 1310nm Port

FMU Plug-in Module, LC/UPC
Data Center & Cloud Computing Infrastructure Solutions



Overview

The CWDM Mux Demux support ITU-T G.694.2 wavelengths from 1470nm to 1610nm in 20nm increments. It is a flexible plug-and-play network solution that allows network operators to cost effectively implement point to point or ring based WDM optical networks.

The main fields of applications are the use in SDH (STM-1, STM-4, STM-16, STM- 64), IP (Fast Ethernet, Gigabit Ethernet, 10 Gigabit) ATM and storage (1G, 2G, 4G, 8G, 10G Fiber Channel) networks.

Highlights

- Multiplexing of up to 8 channels on fiber pair
- Low insertion loss
- Low-profile modular design, fits in FMU 2-slot 1U chassis
- Duplex LC/UPC, easily support duplex patch cables between transceiver and passive unit
- Compliant to ITU-T G.694.2 standard
- Standard 8-channel CWDM band 1470 nm -1610 nm, 20 nm spacing
- Based on thin-film filter technology
- Passive, no electric power required. (MTBF ca. 500 years)

General Specification

Front View	Function
------------	----------

72428

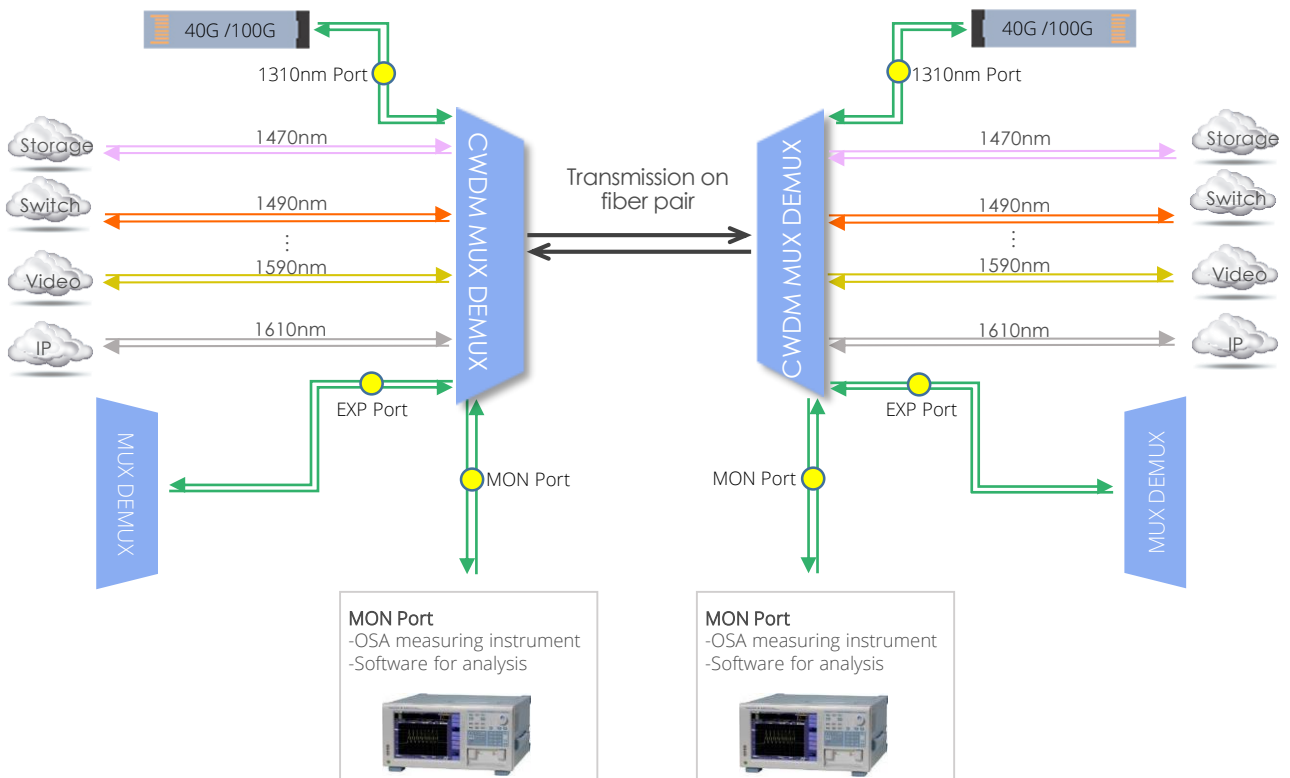

Technical Data

Parameter	Value
Center Wavelength	1470nm, 1490nm, 1510nm, 1530nm, 1550nm, 1570nm, 1590nm, 1610nm
Channel Spacing	20nm
Channel Passband	± 6.5nm
Insertion Loss (passband)	≤ 3.3dB
Insertion Loss (+1% Mon)	≤24.5dB
Insertion Loss (+1310nm port)	≤ 1.3dB
Insertion Loss (+EXP port)	≤ 3.3dB
Adjacent Channel Isolation	≥ 30dB
Non-adjacent Channel Isolation	≥ 40dB
Technology	TFF (Thin Film Filter)
Passband Ripple	≤ 0.3dB
PDL	≤ 0.3dB
Return Loss	≥ 45dB
Directivity	≥ 50dB
PMD	≤ 0.1ps
Power Handling	≤ 500mW
Operating Temperature	-40 ~ +85 ° C
Storage Temperature	-40 ~ +85 ° C
Fiber Type	G657 A1
Dimensions (H x W x D)	1.73"x8.35"x10.04" (44x212x255mm)

Notes:

1.Specified with connectors and adapters.

FS.COM Quality Assurance by Using High-quality CWDM Multiplexers

Our components fulfill or exceed standard market specifications for optical components. It may still not be entirely obvious how different parameters like isolation are more closely defined. The following diagram illustrates the most important parameters, following the "red box model", in accordance with ITU. The channel, including its bandwidth and isolation as defined by the component specifications, delineates a box.

The measured transmission spectrum of each channel has to be above the box. Under no circumstances can it interfere with any neighboring box (channel). Therefore, isolation and insertion losses have to be maintained within the borders set out by the defined center wavelengths and bandwidth.

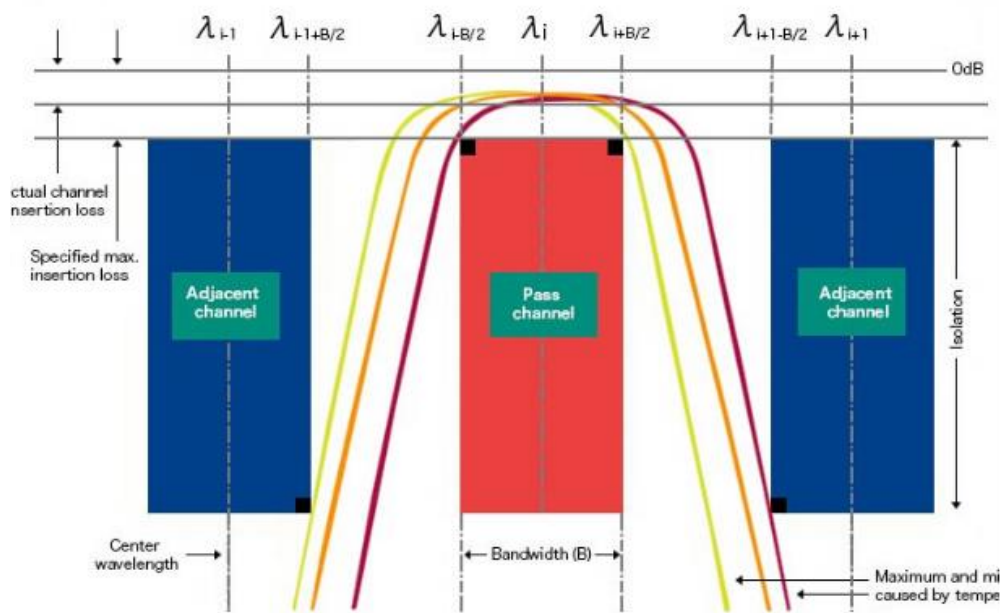

CWDM Mux Demux Series

Application	ID#	Description
WHOLE BAND (1270-1610NM)		
Whole band (1270-1610nm)	#33489	18 Channels 1270-1610nm, with Monitor Port, LC/UPC, Dual Fiber CWDM Mux Demux, FMU 1U Rack Mount
HIGH BAND (1470-1610NM)		
High band (1470-1610nm)	#43099	8 Channels 1470-1610nm, with Expansion Port, LC/UPC, Dual Fiber CWDM Mux Demux, FMU Plug-in Module

High band (1470-1610nm)	#72428	8 Channels 1470-1610nm, with Monitor, Expansion and 1310nm Port, LC/UPC, Dual Fiber CWDM Mux Demux, FMU Plug-in Module
----------------------------	------------------------	--

High band (1470-1610nm)	#78163	8 Channels 1470-1610nm, with Monitor and Expansion Port, LC/UPC, Dual Fiber Low Insertion Loss CWDM Mux Demux, FMU Plug-in Module
----------------------------	------------------------	---

LOW BAND (1270-1450NM)

Low band (1270-1450nm)	#42945	8 Channels 1290-1430nm, LC/UPC, Dual Fiber CWDM Mux Demux, FMU Plug-in Module
---------------------------	------------------------	---

Low band (1270-1450nm)	#42937	8 Channels 1270-1450nm (Skip 1390, 1410nm), LC/UPC, Dual Fiber CWDM Mux Demux, FMU Plug-in Module
---------------------------	------------------------	---

Low band (1270-1450nm)	#42972	4 Channels 1270-1330nm, LC/UPC, Dual Fiber Low Insertion Loss CWDM Mux Demux, FMU Plug-in Module
---------------------------	------------------------	--

SINGLE FIBER

Single fiber	#43711	9 Channels 1270-1590nm, LC/UPC, Single Fiber CWDM Mux Demux, Side-A, Plug-in Module, used together with ID#43699
--------------	------------------------	--

Single fiber	#43699	9 Channels 1290-1610nm, LC/UPC, Single Fiber CWDM Mux Demux, Side-B, Plug-in Module, used together with ID#43711
--------------	------------------------	--

*Standard products are listed above. Customized specifications are available upon request.

Channel Wavelengths and Color Coding for CWDM

For CWDM systems an industry standard color coding scheme is used. The latches of the transceivers match the colored port indicators on the passive units therefore guaranteeing simple setup, following color codes and wavelength are valid for CWDM.

ITU channel no.	Wavelength	Color	Color Coding
27	1270nm	light purple	
29	1290nm	sky blue	
31	1310nm	yellow green	
33	1330nm	yellow ocher	
35	1350nm	pink	
37	1370nm	beige	
39	1390nm	white	
41	1410nm	silver	
43	1430nm	black	

ITU channel no.	Wavelength	Color	Color Coding
45	1450nm	yellow orange	
47	1470nm	gray	
49	1490nm	violet	
51	1510nm	blue	
53	1530nm	green	
55	1550nm	yellow	
57	1570nm	orange	
59	1590nm	red	
61	1610nm	brown	

High Quality CWDM Transceivers to Build a Passive CWDM System

FS.COM offers CWDM transceiver modules in SFP, SFP+, SFP28, 3G-SDI SFP and XFP formats. Every optics is tested in real switches and fully compatible with Cisco, Juniper, Arista, Brocade, Dell, Extreme, etc.

Transmission distances range from 10-80km, transmission data rate range from 1G-25G speeds, without the use of optical amplifiers.



CWDM-SFP

CWDM-10G SFP+

CWDM-25G SFP28

CWDM-3G-SDI-SFP

CWDM-XFP

Layout and Dimensions

- Width: 212.00mm (8.35")
- Height: 44.00mm (1.73")
- Depth: 255.00mm (10.04")
- The color of the module is black
- All fonts and labels are printed in black

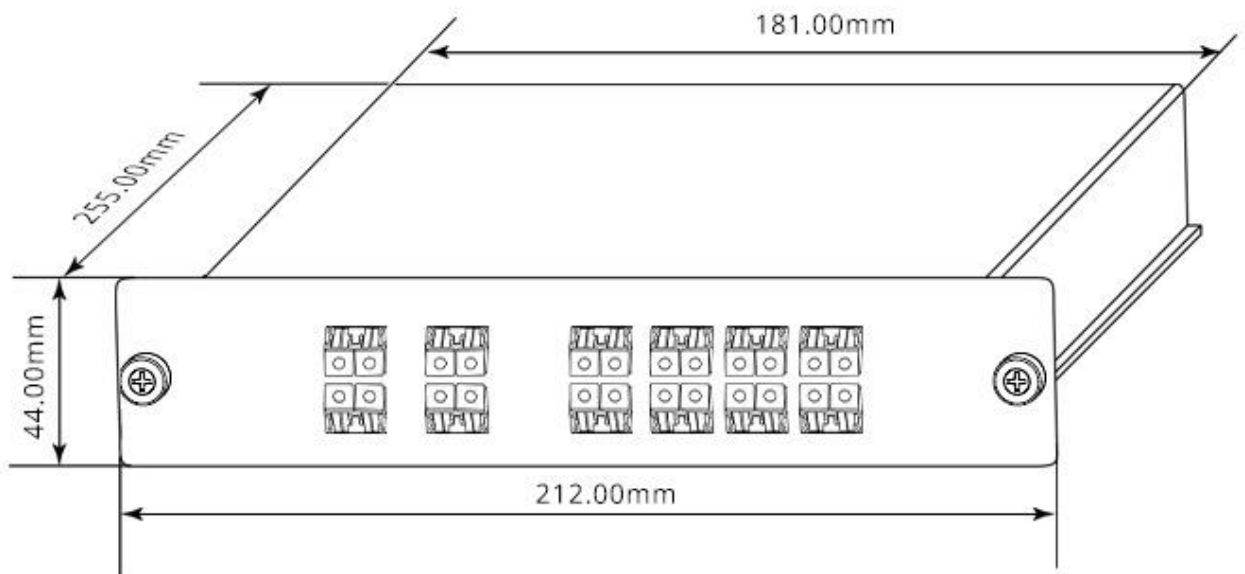



 <https://www.fs.com>



The information in this document is subject to change without notice. FS has made all efforts to ensure the accuracy of the information, but all information in this document does not constitute any kind of warranty.