

XGSPON OLT SFP+

1577nm-Tx/1270nm-Rx 20km

DOM Transceiver

XGS-SFP-52-20N1

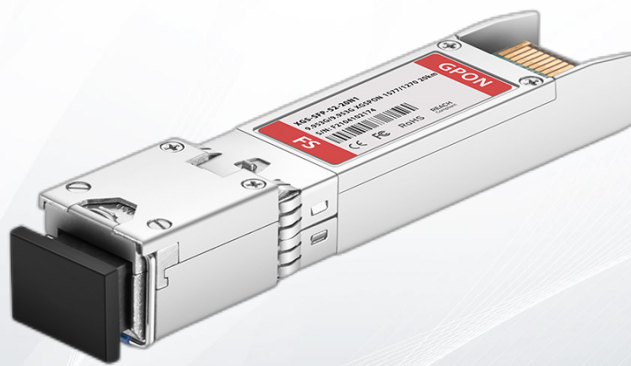

Applications

- SONET OC-3/SDH STM-1
- Fast Ethernet
- Other Optical Links

Features

- SFP+ package with SC receptacle optical interface compliant
- Hot-Pluggable
- 9.953Gbps downstream and 9.953Gbps/2.488Gbps upstream
- +3.3V single power supply
- ROHS Compliant
- Excellent EMI and EMC

Standards

- SFP MSA
- SFF 8472
- ITU-T G.9807.1

Description

XGS-PON OLT product is designed for OLT module based on XGSPON N1 technology. The product is an integrated module containing a micro-optic component and semiconductor material. The module could implement DDM function. It could be used at key locations in optical networks.

Specifications

(tested under recommended operating conditions, unless otherwise noted)

Parameter	Symbol	Unit	Value		
			Min	typical	Max

Electrical Characteristics

Power Consumption		W	-	-	2.5
CML Signal Differential Data Input Swing		mV	100	-	800
CML Single Differential Data Output Swing		mV	600		1000
Differential Data input impedance		Ω	-	100	-
Signal Level(LVTTL)	VOH	V	2.4	-	Vcc
	VOL	V	0	-	0.8

Optical transmitter Characteristics

DataRate		Mbps	--	9953.28	-
Center Wavelength Range	lc	nm	1575	-	1580
Spectral Width(@-20dB)	DI	nm	-	-	1
Launch Optical Power	Po	dBm	+2	-	+5

Parameter	Symbol	Unit	Value		
			Min	typical	Max

Pout@TX-Disable Asserted	Poff	dBm			-39
--------------------------	------	-----	--	--	-----

Extinction Ratio1	EX	dB	8.2	-	-
-------------------	----	----	-----	---	---

Eye Diagram

Compliant with ITU-T G.987.2

Transmitter dispersion penalty 2	TDP	dB	-	-	1
----------------------------------	-----	----	---	---	---

Optical receiver Characteristics (10G)

DataRate		Mbps	-	9953.28	-
----------	--	------	---	---------	---

Center Wavelength Range	lc	nm	1260	1270	1280
-------------------------	----	----	------	------	------

Receiver Sensitivity 3	S	dBm	-	-	-26
------------------------	---	-----	---	---	-----

Over load Input Optical Power	Pin	dBm	-5		
-------------------------------	-----	-----	----	--	--

LOS	OpticalDessert		dB	-	-
	OpticalAssert			-45	-

LOS Hysteresis		dB	0.5	-	6
----------------	--	----	-----	---	---

Optical receiver Characteristics (2.5G)

Data Rate		Mbps	-	2488.32	-
-----------	--	------	---	---------	---

Center Wavelength Range	lc	nm	1260	1270	1280
-------------------------	----	----	------	------	------

Receiver Sensitivity4	S	dBm	-	-	-27.5
-----------------------	---	-----	---	---	-------

Parameter	Symbol	Unit	Value		
			Min	typical	Max
Overload Input Optical Power	Pin	dBm	-7		
LOS	Optical Dessert		dB	-	-
	Optical Assert			-45	-
LOSHysteresis		dB	0.5	-	6

Notes:

1. Measured with PRBS 2³¹-1 test pattern @9.95328Gbps .
2. Transmit on 20km SMF.
3. Measured with PRBS 231-1 test pattern @9.953Gbps , BER=10⁻³
4. Measured with PRBS 223-1 test pattern @2.48832Gbps , BER=10⁻⁴

Ordering Information

Parameter	Specifications								
	Package	Datarate	Laser	OpticalPower	Detector	Sensitivity	Top	Reach	Others
XGS-PON OLT	SFP+	9.95328G/2.48832GUS9.95328GDS	1577nm EML	+2~-+5dBm	APD1270nm	10G:-26dBm2.5G:-27.5dBm	0~70oC	20km	DDM,RoHS

Absolute Maximum Ratings

Parameter	Symbol	Unit	Min	Max
Storage Temperature Range	T _s	oC	-40	+85
Relative Humidity	RH	%	5	95
Power Supply Voltage	V _{cc}	V	0	+3.6
Receiver Damage Threshold		dBm	0	-

Recommended Operating Conditions

Parameter	Symbol	Unit	Min	Typ	Max
Operating Case Temperature Range	T _c	° C	-5	-	75
Power Supply Voltage	V _{cc}	V	3.135	3.3	3.465

Principle diagram

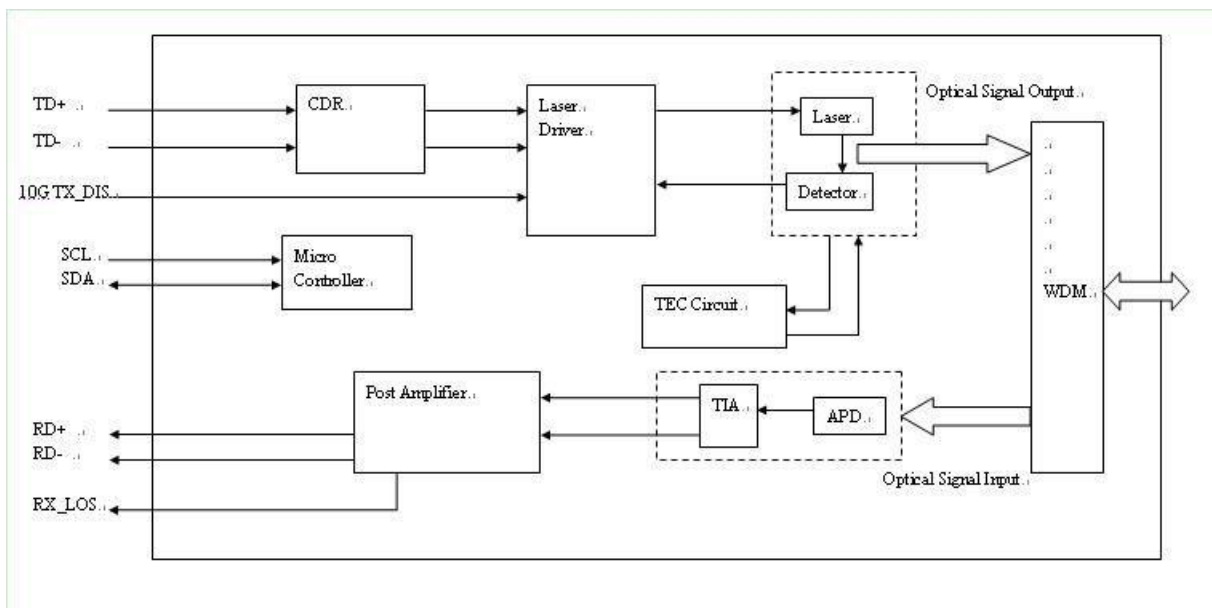

Optic Ports Definition

Single SC receptacle optical interface

Electric Ports Definition

Pin	Name	Description	Pin	Name	Description
1	GND_T	Transmitterground	20	GND_T	Transmitterground
2	TX_FAULT	LVTTTL Signal detect output	19	TD -	LVPECL Data input- (AC coupled and internal terminated)
3	Transmitter Disable	(Note1)	18	TD+	(ACcoupledandinternalterminated)
4	SDA	I ² C SerialData (LVTTTL)	17	GND_T	Transmitterground
5	SCL	I ² C SerialClock (LVTTTL)	16	VCC_T	Transmitterpowersupply
6	MOS_ABS	InternallyconnectedGND	15	VCC_R	Receiverpowersupply
7	RESET	RXReset (LVTTTL)	14	GND_R	Receiverground
8	RX_SD	LVTTTL Signal detect output, internally pull up(Note2)	13	RD+	CML data output+(DC coupled
9	RSSI TRIG	Receiver RSSI trigger input	12	RD-	CML data output-(DC coupled and internal terminated)
10	GND_R	Receiver ground	11	GND_R	Receiver ground

Notes:

1. TX Disable input is used to shut down both the 10G laser and 1G laser (if module has 1G transmitter) output per the state table below. It is pulled up within the module with a 4.7 – 10K resistor.

Low (<0.8V): Transmitter on

High (>2.0 V): Transmitter Disabled

Open : Transmitter Disabled

2. SD (signal Detect) is an open collector/drain output which should be pulled up externally with a 4.7 – 10K resistor on the host board to supply $V_{ccT}+0.3V$ or $V_{ccR}+0.3V$. When low, this output indicates the received optical power is below the worst case receiver sensitivity. High indicates normal operation. In the low state, the output will be pulled to <math><0.8V</math>.

3. RX_RSSI_TRIG is used to start a RX Power Monitoring. It is pulled high to trigger a A/D sample start. The timing is shown as below:

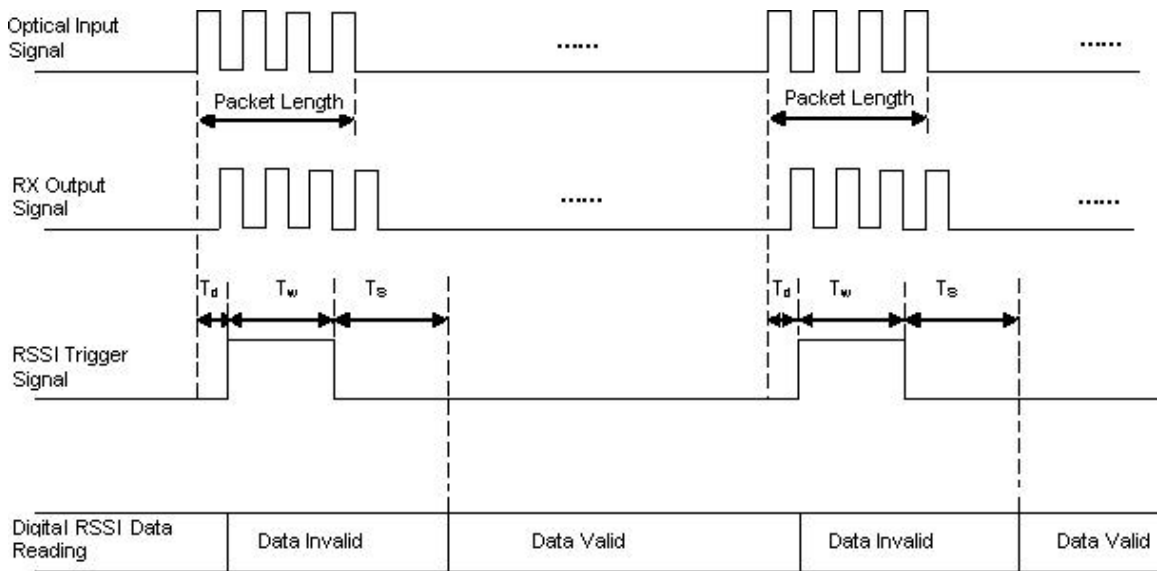

PARAMETER	SYMBOL	MIN	TYP	MAX	UNITS
Packet Length	-	550	-	-	ns
Trigger delay	T_d	25	-	-	ns
RSSI Trigger and Sample Time	T_w	500	-	-	ns
Internal delay	T_s	500	-	-	us
Packet Length	-	550	-	-	ns

Typical Application Circuit

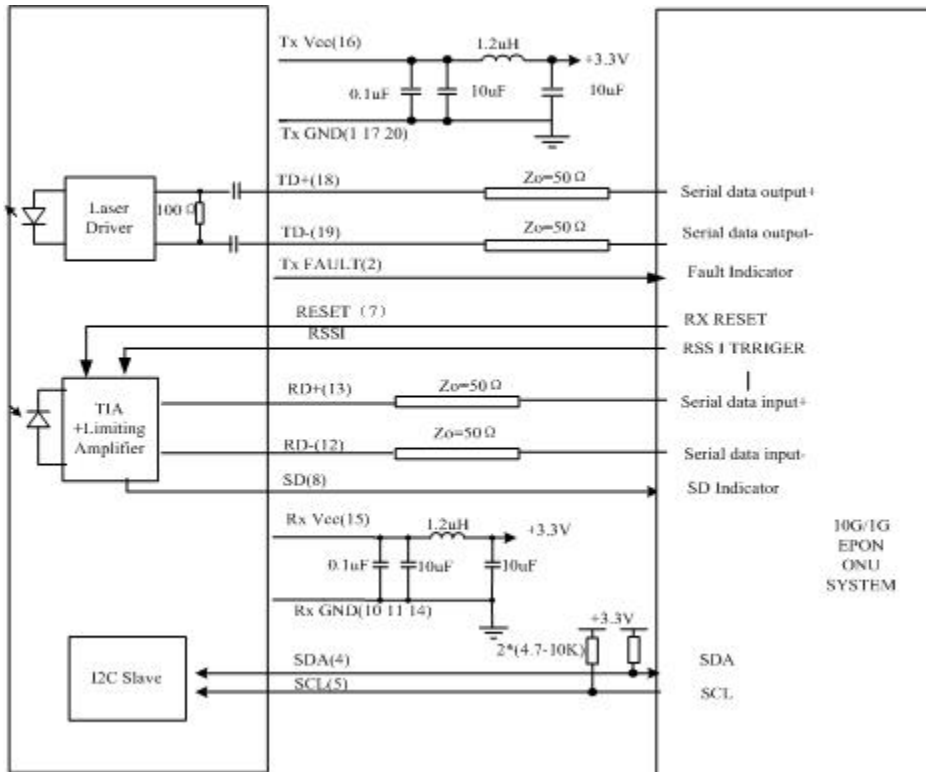
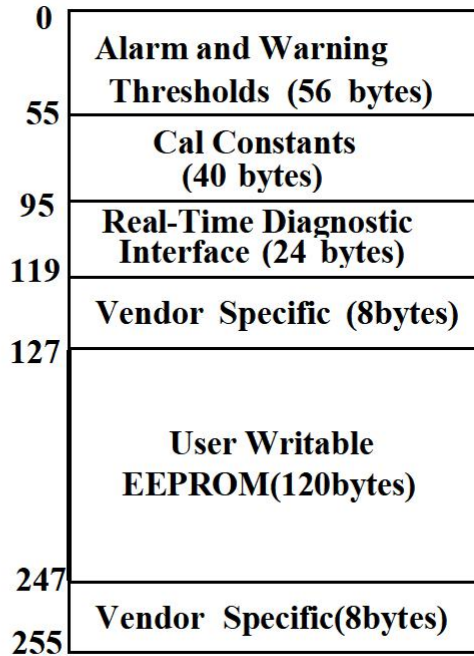
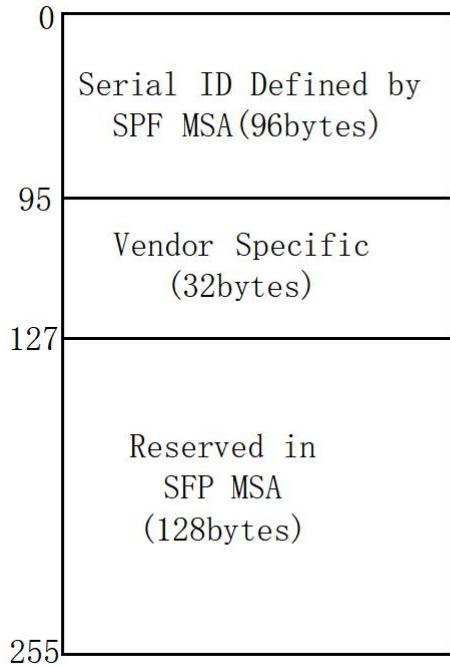

Figure 6. Mechanical Drawing

Digital Diagnostic Memory Map

2 wire address 1010000X (A0)

2 wire address 1010001X (A2)



EEPROM Serial ID Memory Contents

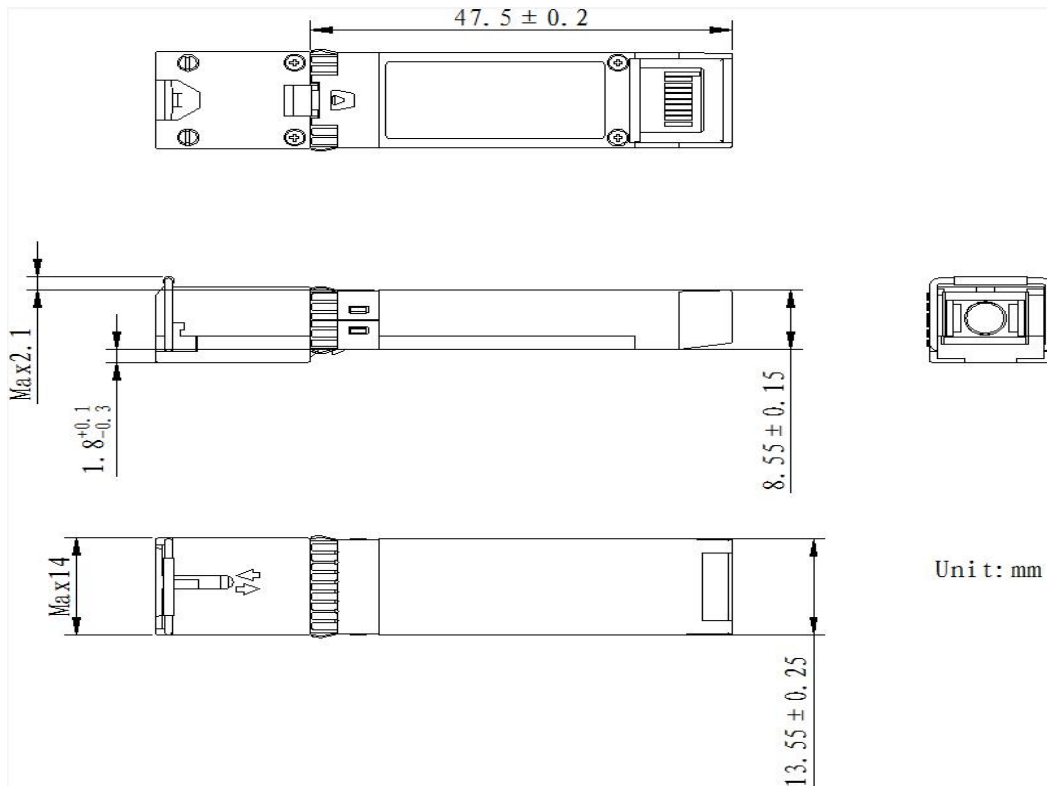

Regulatory Compliance

Feature	Test Method	Performance
Electrostatic Discharge (ESD) to the Electrical Pins	MIL-STD-883E Method 3015.7	Class 1 (>1.5kV) – Human Body Model
Electrostatic Discharge (ESD) Immunity	IEC61000-4-2	LV4(Air discharge 15kV,Contact discharge 8kV) Performance criterion B
Electromagnetic Interference (EMI)	CISPR22 ITE Class B EN55022 Class B	Compliant with standards
Immunity	IEC61000-4-3 Class 2 EN55024	Typically show no measurable effect from a 3V/m field swept from 80 to 1000MHz applied to the transceiver without a chassis enclosure
Eye Safety	FDA 21 CFR 1040.10 and 1040.11	
	Compliant with Class 1 laser productUL	
	TUV EN 60825-1	



 <https://www.fs.com>



The information in this document is subject to change without notice. FS has made all efforts to ensure the accuracy of the information, but all information in this document does not constitute any kind of warranty.