

10G CWDM SFP+

1270nm~1450nm 40km

DOM Transceiver

CWDM-SFP10G-40S



Application

- 10GBASE-ER/EW 10G Ethernet
- 10GBASE-ER at 10.31Gbps
- 10GBASE-EW at 9.95Gbps
- OBSAI rates 6.144 Gb/s, 3.072 Gb/s, 1.536 Gb/s, 0.768Gb/s
- CPRI rates 9.830 Gb/s, 7.373Gb/s, 6.144 Gb/s, 4.915 Gb/s, 2.458 Gb/s, 1.229 Gb/s, 0.614Gb/s
- Other optical links

Features

- Hot-Pluggable SFP+ Footprint
- Duplex LC connector
- Commercial temperature range: 0° C to 70° C
- 10-Wavelengths CWDM DFB Transmitter from 1270nm to 1450nm, with step 20nm
- Power Dissipation <1.2W
- Compliant with SFP+ MSA Specification SFF-8431
- 14dB Power Budget
- Build-in digital diagnostic functions, including optical power monitoring
- Compliant with SFF-8472 MSA

Description

The CWDM-SFP10G-40S series optical transceiver is designed for fiber communications application such as 10G Ethernet, which fully compliant with the specification of SFP+ MSA SFF-8431.

This module is designed for single mode fiber and operates at a nominal wavelength of CWDM wavelength. There are ten center wavelengths available from 1270nm to 1450nm, with each step 20nm. A guaranteed optical link budget of 14 dB is offered.

The module is with the SFP+ connector to allow hot plug capability. Single 3.3V power supply is needed. The optical output can be disabled by LVTTTL logic high-level input of TX_DIS. Loss of signal (RX_LOS) output is provided to indicate the loss of an input optical signal of receiver.

This module provides digital diagnostic functions via a 2-wire serial interface as defined by the SFF-8472 specification.

Product Specifications

I. General Specifications

Parameter	Symbol	Min	Typ.	Max	Unit	Ref.
Module Form Factor	BR	9.95		10.5	Gb/s	1
Number of Lanes	BER			10 ⁻¹²		2
Maximum Aggregate Data Rate	L _{max}		40		km	

Notes:

- 10GBASE-ER, 10GBASE-EW, 1200-SM-LL-L 10GFC.
- Tested with a PRBS 2³¹-1 test pattern.

CWDM Wavelength

18 Wavelengths from 1270nm to 1610nm, each step 20nm.

Band	Nomenclature	Wavelength(nm)		
		Min	Typ.	Max
O-band Original	A	1264	1270	1277.5
	B	1284	1290	1297.5
	C	1304	1310	1317.5
	D	1324	1330	1337.5
	E	1344	1350	1357.5
E-band Extended	F	1364	1370	1377.5
	G	1384	1390	1397.5
	H	1404	1410	1417.5
	I	1424	1430	1437.5
	J	1444	1450	1457.5
S-band Short Wavelength	K	1464	1470	1477.5
	L	1484	1490	1497.5
	M	1504	1510	1517.5
	N	1524	1530	1537.5
C-band Conventional	O	1544	1550	1557.5
L-band Long Wavelength	P	1564	1570	1577.5
	Q	1584	1590	1597.5
	R	1604	1610	1617.5

II. Absolute Maximum Ratings

Parameter	Symbol	Min	Typ.	Max	Unit
Maximum Supply Voltage ¹	V _{cc}	-0.5		4.0	V
Storage Temperature	T _s	-40		85	° C
Case Operating Temperature	T _c	0		70	° C
Supply Voltage	V _{cc}	3.13	3.3	3.45	V
Supply Current	I _{cc} (0° C to 70° C)			350	mA

III. Electrical Characteristics

Parameter	Symbol	Min	Typ.	Max	Unit	Notes
Transmitter						
0	V _{in}	150		1200	mVpp	1
Input Impedance (Differential)	Z _{in}	85	100	115	ohm	
TX_DISABLE Input Voltage - High		2		V _{cc} +0.3	V	
TX_DISABLE Input Voltage - Low		0		0.8	V	
TX_FAULT Output Voltage - High		2		V _{cc} +0.3	V	
TX_FAULT Output Voltage - Low		0		0.5	V	

Receiver

CML Outputs (Differential)	Vout	350		700	mVpp	1
Output Impedance (Differential)	Zout	85	100	115	ohm	
RX_LOS Output Voltage - High		2		Vcc+0.3	V	
RX_LOS Output Voltage - Low		0		0.8	V	
MOD_DEF (2:0)	VoH	2.5			V	2
	VoL	0		0.5	V	

Notes:

1. After internal AC coupling.
2. Reference the SFF-8472 MSA.

IV. Optical Characteristics

Parameter	Symbol	Min	Typ.	Max	Unit	Notes
Transmitter						
Optical Wavelength	λ	$\lambda_c-6.5$	λ_c	$\lambda_c+6.5$	nm	2
-20dB Spectrum Width	$\Delta\lambda$			1	nm	
Side Mode Suppression Ratio	SMSR	30			dB	
Output Opt. Pwr: 9/125 SMF	P _{out}	0		5	dBm	1
Optical Extinction Ratio	ER	3.5			dB	
Average Launch Power of OFF Transmitter	P _{OFF}			-30	dBm	
Transmitter Dispersion Penalty	TDP			2	dB	

Receiver

Receiver Sensitivity @ 10.5Gb/s	P_{min}			-16	dBm	3
Maximum Input Power	P_{max}	-0.5			dBm	
Optical Center Wavelength	λ	1260		1420	nm	
Receiver Reflectance	Rrf			-27	dB	
LOS De-Assert	LOS_D			-16	dBm	
LOS Assert	LOS_A	-28			dBm	
LOS Hysteresis		1			dB	

Notes:

1. Output power is coupled into a 9/125 μ m SMF.
2. ITU-T G.694.2 CWDM wavelength from 1470nm to 1610nm, each step 20nm.
3. Average received power; BER less than 1E-12 and PRBS 2³¹-1 test pattern.

V. Pin Description

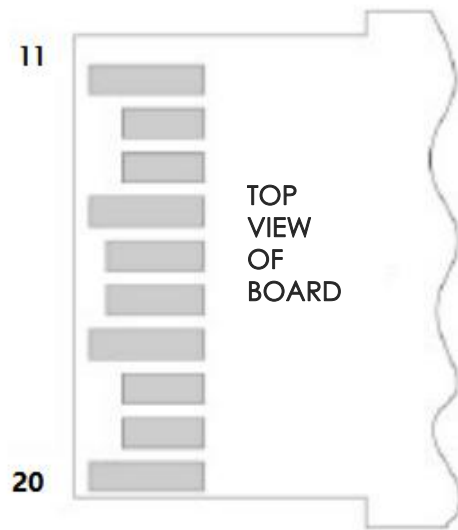
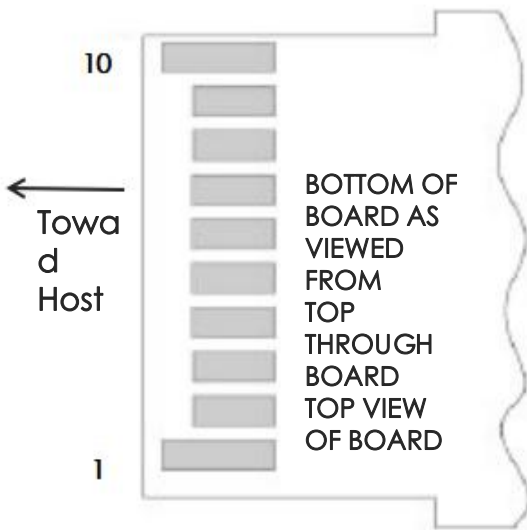
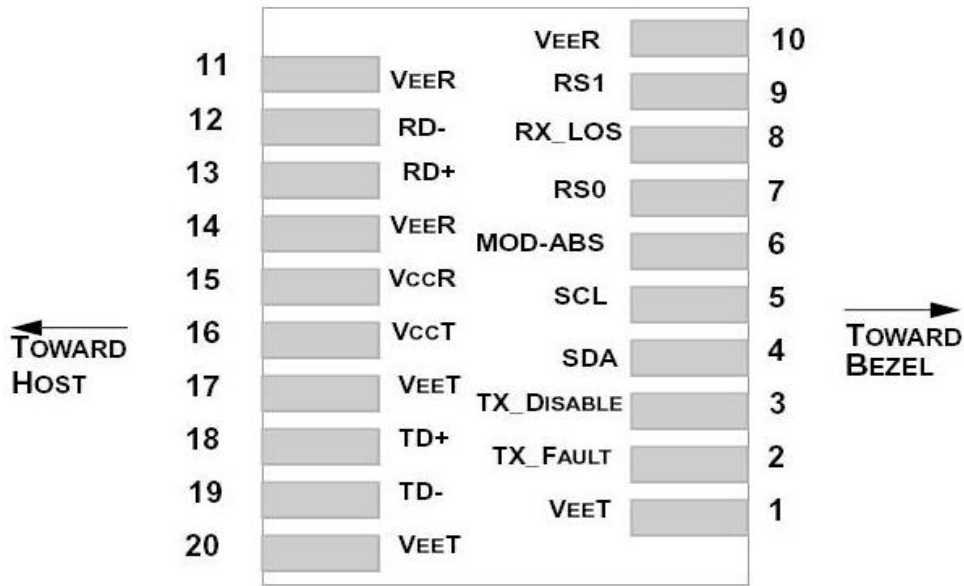

Pin Num.	Name	Function	Plug Seq.	Notes
1	VeeT	Transmitter Ground	1	Note 5
2	TX Fault	Transmitter Fault Indication	3	Note 1
3	TX Disable	Transmitter Disable	3	Note 2, Module disables on high or open
4	SDA	Module Definition 2	3	Data line for Serial ID.

5	SCL	Module Definition 1	3	Clock line for Serial ID.
6	MOD-ABS	Module Definition 0	3	Note 3
7	RS0	RX Rate Select (LVTTTL).	3	This pin has an internal 30k pull down to ground. A signal on this pin will not affect module performance.
8	LOS	Loss of Signal	3	Note 4
9	RS1	TX Rate Select (LVTTTL).	1	This pin has an internal 30k pull down to ground. A signal on this pin will not affect module performance.
10	VeeR	Receiver Ground	1	Note 5
11	VeeR	Receiver Ground	1	Note 5
12	RD-	Inv. Received Data Out	3	Note 6
13	RD+	Received Data Out	3	Note 6
14	VeeR	Receiver Ground	1	Note 5
15	VccR	Receiver Power	2	3.3V ± 5%, Note 7
16	VccT	Transmitter Power	2	3.3V ± 5%, Note 7
17	VeeT	Transmitter Ground	1	Note 5
18	TD+	Transmit Data In	3	Note 8
19	TD-	Inv. Transmit Data In	3	Note 8
20	VeeT	Transmitter Ground	1	Note 5

Notes:

1. TX Fault is an open collector/drain output, which should be pulled up with a 4.7K –10KΩ resistor on the host board. Pull up voltage between 2.0V and VccT/R+0.3V. When high, output indicates a laser fault of some kind. Low indicates normal operation. In the low state, the output will be pulled to < 0.8V.
2. TX disable is an input that is used to shut down the transmitter optical output. It is pulled up within the module with a 4.7K~10 KΩ resistor. Its states are: Low (0 – 0.8V): Transmitter on (>0.8, < 2.0V): Undefined High (2.0 – 3.465V): Transmitter Disabled Open: Transmitter Disabled
3. Module Absent, connected to VeeT or VeeR in the module.
4. LOS (Loss of Signal) is an open collector/drain output, which should be pulled up with a 4.7K –10 KΩ resistor on host board. Pull up voltage between 2.0V and VccT/R+0.3V. When high, this output indicates the received optical power is below the worst-case receiver sensitivity (as defined by the standard in use). Low indicates normal operation. In the low state, the output will be pulled to < 0.8V.

5. VeeR and VeeT may be internally connected within the SFP+ module.
6. RD-/+ : These are the differential receiver outputs. They are AC coupled 100Ω differential lines which should be terminated with 100Ω (differential) at the user SERDES. The AC coupling is done inside the module and is thus not required on the host board. The voltage swing on these lines will be between 370 and 700 mV differential (185 –350mV single ended) when properly terminated.
7. VccR and VccT are the receiver and transmitter power supplies. They are defined as 3.3V ± 5% at the SFP+ connector pin. Maximum supply current is 350mA. Recommended host board power supply filtering is shown below. Inductors with DC resistance of less than 1 ohm should be used in order to maintain the required voltage at the SFP+ input pin with 3.3V supply voltage. When the recommended supply filtering network is used, hot plugging of the SFP+ transceiver module will result in an inrush current of no more than 30mA greater than the steady state value. VccR and VccT may be internally connected within the SFP+ transceiver module.
8. TD-/+ : These are the differential transmitter inputs. They are AC-coupled, differential lines with 100Ω differential termination inside the module. The AC coupling is done inside the module and is thus not required on the host board. The inputs will accept differential swings of 150 – 1200 mV (75 – 600mV single-ended), though it is recommended that values between 150 and 1200 mV differential (75 – 600mV single-ended) be used for best EMI performance.

VI. Mechanical Specifications

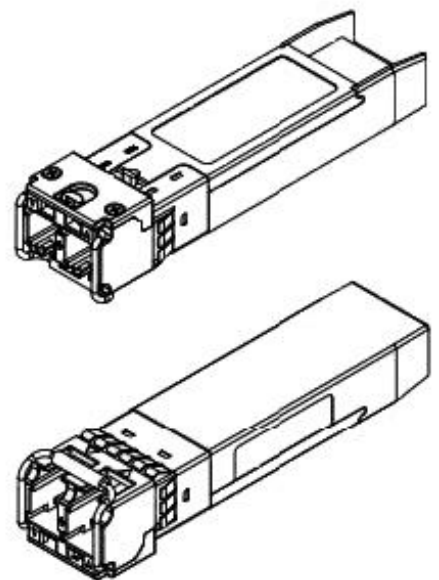
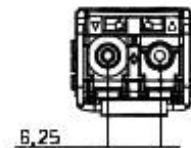
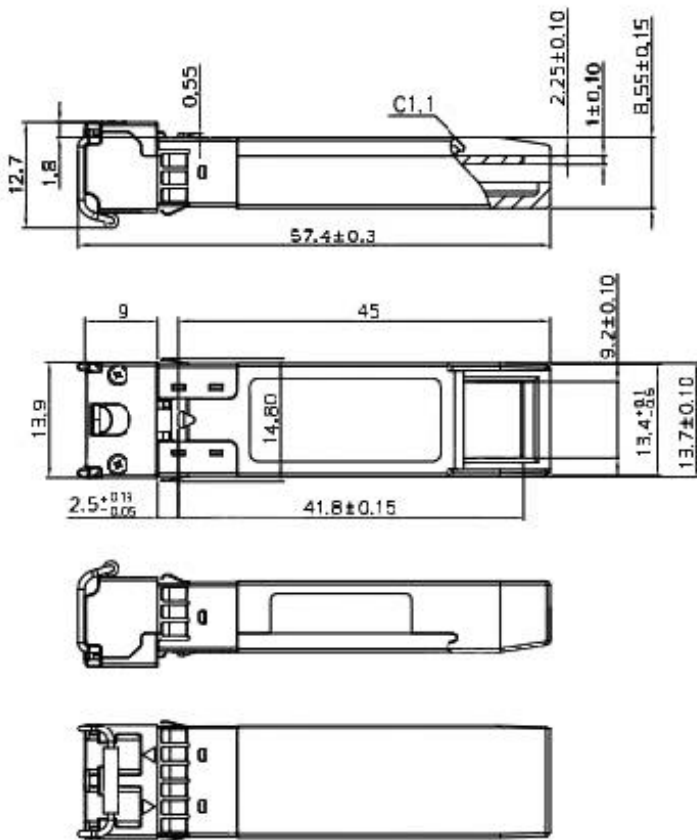

Unremarked tolerances ±0.2mm

Test Center

FS.COM transceivers are tested to ensure connectivity and compatibility in our test center before shipped out. FS.COM test center is supported by a variety of mainstream original brand switches and groups of professional staff, helping our customers make the most efficient use of our products in their systems, network designs and deployments.

The original switches could be found nowhere but at FS.COM test center, eg: Juniper MX960 & EX 4300 series, Cisco Nexus 9396PX & Cisco ASR 9000 Series, HP 5900 Series & HP 5406R ZL2 V3(J9996A), Arista 7050S-64, Brocade ICX7750-26Q & ICX6610-48, Avaya VSP 7000 MDA 2, etc.



Cisco ASR 9000 Series(A9K-MPA-1X40GE)



ARISTA 7050S-64(DCS-7050S-64)



Juniper MX960



Brocade ICX 7750-26Q



Extreme Networks X670V VIM-40G4X



Mellanox M3601Q



Dell N4032F



HP 5406R ZL2 V3(J9996A)



AVAYA 7024XLS(7002QQ-MDA)

Test Assured Program

FS.COM truly understands the value of compatibility and interoperability to each optics. Every module FS.COM provides must run through programming and an extensive series of platform diagnostic tests to prove its performance and compatibility. In our test center, we care of every detail from staff to facilities—professionally trained staff, advanced test facilities and comprehensive original-brand switches, to ensure our customers to receive the optics with superior quality.

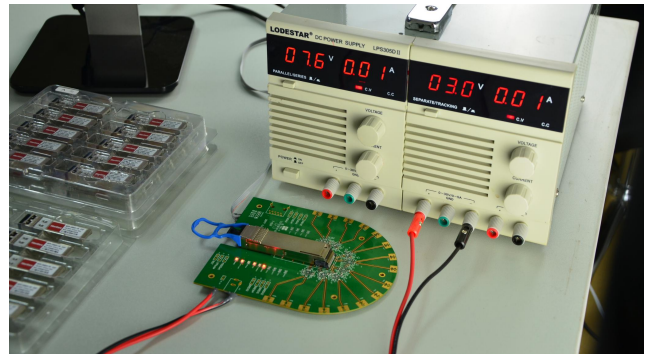

Our smart data system allows effective product management and quality control according to the unique serial number, properly tracking the order, shipment and every part.

Our in-house coding facility programs all of our parts to standard OEM specs for compatibility on all major vendors and systems such as Cisco, Juniper, Brocade, HP, Dell, Arista and so on.



With a comprehensive line of original-brand switches, we can recreate an environment and test each optics in practical application to ensure quality and distance.

The last test assured step to ensure our products to be shipped with perfect package.

Order Information

Part Number	Description
CWDM-SFP10G-20SP	SFP+, 10GBase-LR, CWDM 1270nm-1330nm, SMF, 20km, LC, DOM
CWDM-SFP10G-20L	SFP+, 10GBase-LR, CWDM 1350nm-1610nm, SMF, 20km, LC, DOM
CWDM-SFP10G-40S	SFP+, 10GBase-ER, CWDM 1270nm-1450nm, SMF, 40km, LC, DOM
CWDM-SFP10G-40L	SFP+, 10GBase-ER, CWDM 1470nm-1610nm, SMF, 40km, LC, DOM
CWDM-SFP10G-80L	SFP+, 10GBase-ZR, CWDM 1470nm-1610nm, SMF, 80km, LC, DOM

Note:

1.10G CWDM SFP+ transceiver module is individually tested on corresponding equipment such as Cisco, Arista, Juniper, Dell, Brocade and other brands, and passes the monitoring of FS.COM intelligent quality control system.



 <https://www.fs.com>



The information in this document is subject to change without notice. FS has made all efforts to ensure the accuracy of the information, but all information in this document does not constitute any kind of warranty.