

# 400G QSFP-DD Passive Copper Twinax Cable (PCC)



## Application

- Data Center & Networking Equipment
- Servers/Storage Devices
- High Performance Computing (HPC)
- Switches/Routers

## Standards Compliance

- IEEE802.3Bj, By, IEEE802.3CD
- RoHS Compliant

## Features

- Compliant with QSFP-DD MSA Specification Rev 3.4
- SFF-8679 electrical interface compliant
- SFF-8636 management interface support
- Support 50G (PAM4) electrical data rates/channel
- I2C for EEPROM communication
- Excellent EMI/EMC performance 360 degree cable shield termination
- Advantage dual side pre-solder automated assembly technologies
- Low loss, stronger mechanical features, more flexible
- QSFP-DD modules will be backwards compatible, allowing them to support existing QSFP modules and provide flexibility for end users and system designers

## Description

In an effort to keep up with the demands of higher performance and increasing amounts of memory bus bandwidth, FS designers are working to revise, extend and update the solution. FS 400G QSFP-DD passive cable assembly can provide new generation performance of QSFP by higher data transfer rate. At the same time, FS QSFP-DD cable choose dual side drain cable and self-designed PCBA, provide low loss, less skew and better NEXT. 360 degree EMI crimping shielding and Zinc Die-cast shell designing make the product high-performance. And all the designing is based on the industry standard specifications, such as SFF-8679, SFF-8636 and QSFP-DD MSA specification rev 4.0.

## I. Schematic

WIRING TABLE---QSFP-DD TO QSFP-DD

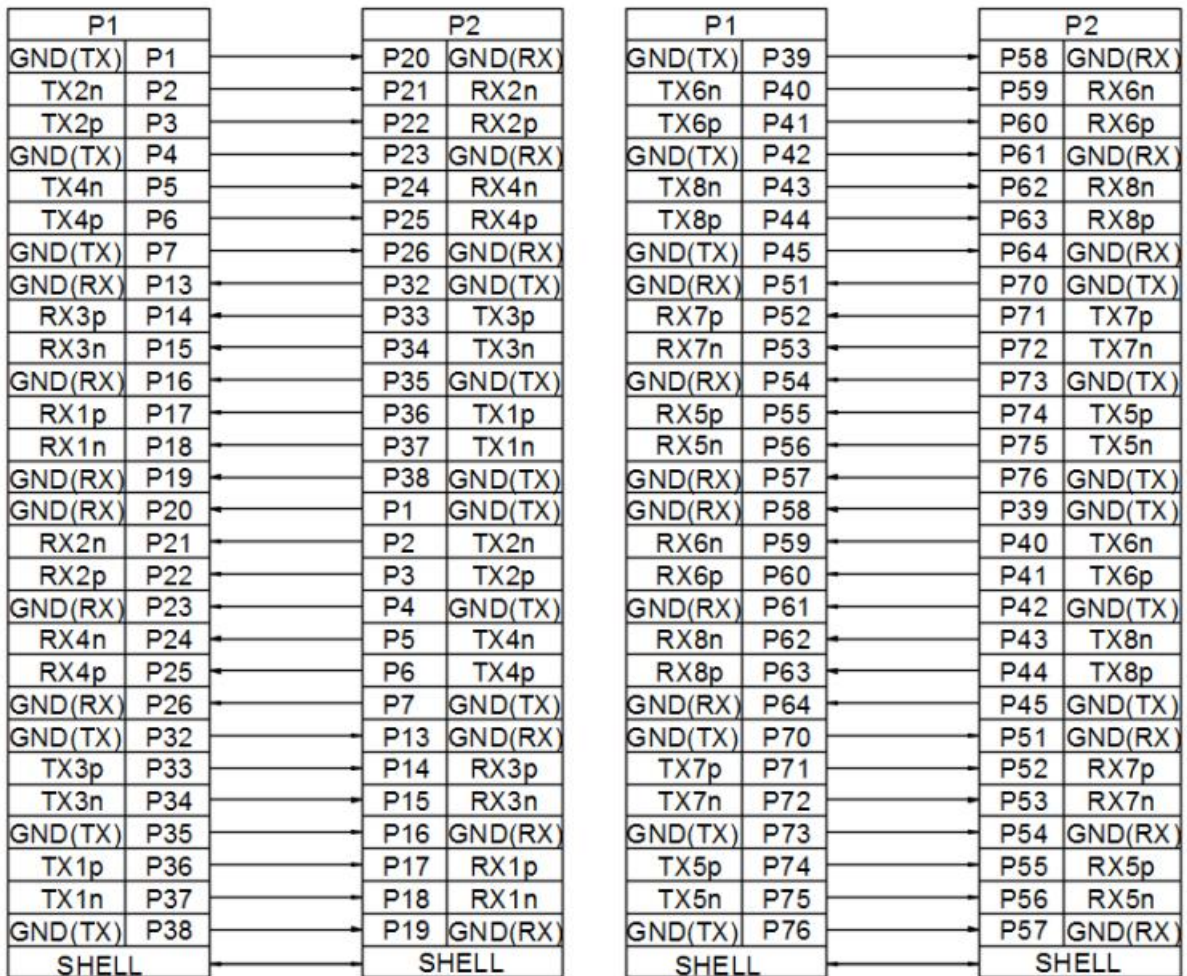

## II. Mechanical Structure Characteristics Of Plug

1. Raw Cable -- Support 28~30AWG, 100ohm, Silver plated, vw-1, RoHS2.0
2. PCB -- High Speed Very low loss material M6,8 Layers Design; Gold finger plated gold 30u" min., nickel plated 150~700u"; pad: immersion gold 1u" min., nickel plated 100u"min. 94v-0, RoHS2.0
3. Upper shell -- Zinc Die-cast, with Cu plated 280u" min. overall and Ni plated 120u" min
4. Bottom shell -- Zinc Die-cast, with Cu plated 280u" min. overall and Ni plated 120u" min
5. Latch -- Stainless steel ,SUS304 + PA66 CM3004,black
6. Spring -- Stainless steel ,SUS301EH
7. Rivet -- Stainless Steel, SUS304
8. SR (Strain Relief) -- PVC, 45P, BLACK, RoHS2.0
9. Dust Cover -- PVC, 60P, Blue, ANTI-STATIC, RoHS2.0

## III. Electrical Design

The electrical design of the QSFP-DD cable assembly is fully compliant to QSFP-DD Hardware Rev4.0 specifications. The electrical design included: a low loss design printed circuit board, DC block capacitances in the Rx channel, and EEprom chips for the management. Pin layout and function definition are shown in Figure 4 and Table 2.

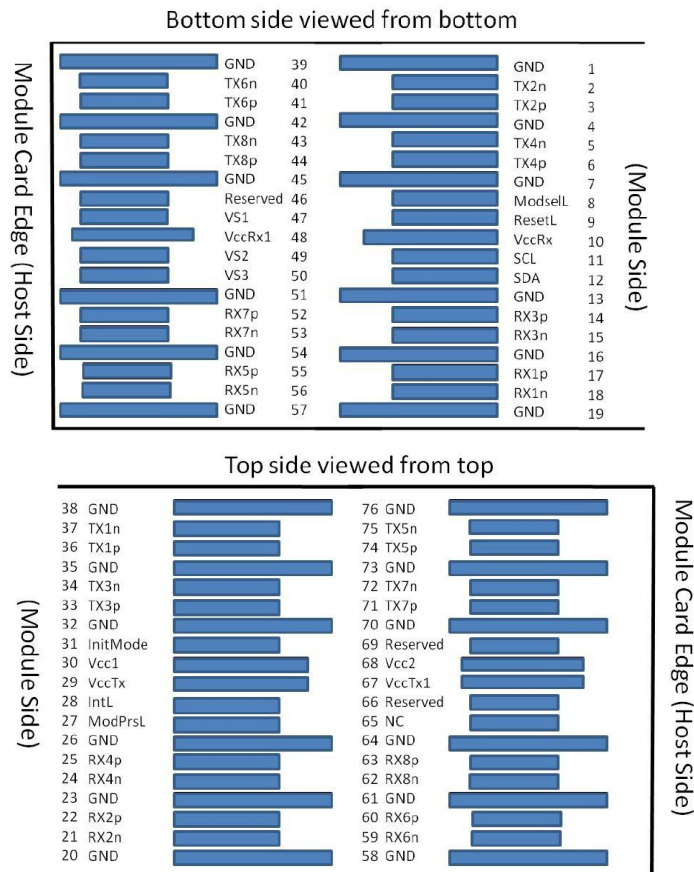

Figure QSFP-DD Pin Define

## IV. Pin Designation

Pin	Logic	Symbol	Name/Description	Notes
1		GND	Ground	
2	CML-I	Tx2n	Transmitter Inverted Data Input	
3	CML-I	Tx2p	Transmitter Non-Inverted Data Input	
4		GND	Ground	1
5	CML-I	Tx4n	Transmitter Inverted Data Input	
6	CML-I	Tx4p	Transmitter Non-Inverted Data Input	
7		GND	Ground	1
8	LVTTTL-I	ModSelL	Module Select	
9	LVTTTL-I	ResetL	Module Reset	
10		VccRx	+3.3V Power Supply Receiver	2
11	LVC MOS-I/O	SCL	2-wire serial interface clock	
12	LVC MOS-I/O	SDA	2-wire serial interface data	
13		GND	Ground	1
14	CML-O	Rx3p	Receiver Non-Inverted Data Output	
15	CML-O	Rx3n	Receiver Inverted Data Output	
16		GND	Ground	1
17	CML-O	Rx1p	Receiver Non-Inverted Data Output	
18	CML-O	Rx1n	Receiver Inverted Data Output	
19		GND	Ground	1
20		GND	Ground	1

21	CML-O	Rx2n	Receiver Inverted Data Output	
22	CML-O	Rx2p	Receiver Non-Inverted Data Output	
23		GND	Ground	1
24	CML-O	Rx4n	Receiver Inverted Data Output	
25	CML-O	Rx4p	Receiver Non-Inverted Data Output	
26		GND	Ground	1
27	LVTTL-O	ModPrsL	Module Present	
28	LVTTL-O	IntL	Interrupt	
29		VccTx	+3.3V Power Supply Transmitter	2
30		VccI	+3.3V Power Supply	2
31	LVTTL-I	InitMode	Initialization mode; In legacy QSFP applications, the InitMode pad is called LPMODE	
32		GND	Ground	1
33	CML-I	Tx3p	Transmitter Non-Inverted Data Input	
34	CML-I	Tx3n	Transmitter Inverted Data Input	
35		GND	Ground	1
36	CML-I	Tx1p	Transmitter Non-Inverted Data Input	
37	CML-I	Tx1n	Transmitter Inverted Data Input	
38		GND	Ground	1
39		GND	Ground	1
40	CML-I	Tx6n	Transmitter Inverted Data Input	
41	CML-I	Tx6p	Transmitter Non-Inverted Data Input	
42		GND	Ground	1

43	CML-I	Tx8n	Transmitter Inverted Data Input	
44	CML-I	Tx8p	Transmitter Non-Inverted Data Input	
45		GND	Ground	1
46		Reserved	For future use	3
47		VSI	Module Vendor Specific 1	3
48		VccRx1	3.3V Power Supply	2
49		VS2	Module Vendor Specific 2	3
50		VS3	Module Vendor Specific 3	3
51		GND	Ground	1
52	CML-O	Rx7p	Receiver Non-Inverted Data Output	
53	CML-O	Rx7n	Receiver Inverted Data Output	
54		GND	Ground	1
55	CML-O	Rx5p	Receiver Non-Inverted Data Output	
56	CML-O	Rx5n	Receiver Inverted Data Output	
57		GND	Ground	1
58		GND	Ground	1
59	CML-O	Rx6n	Receiver Inverted Data Output	
60	CML-O	Rx6p	Receiver Non-Inverted Data Output	
61		GND	Ground	1
62	CML-O	Rx8n	Receiver Inverted Data Output	
63	CML-O	Rx8p	Receiver Non-Inverted Data Output	
64		GND	Ground	1

65		NC	No Connect	3
66		Reserved	For future use	3
67		VccTx1	3.3V Power Supply	2
68		Vcc2	3.3V Power Supply	2
69		Reserved	For future use	3
70		GND	Ground	1
71	CML-I	Tx7p	Transmitter Non-Inverted Data Input	
72	CML-I	Tx7n	Transmitter Inverted Data Input	
73		GND	Ground	1
74	CML-I	Tx5p	Transmitter Non-Inverted Data Input	
75	CML-I	Tx5n	Transmitter Inverted Data Input	
76		GND	Ground	1

## Notes:

1. QSFP-DD uses common ground (GND) for all signals and supply (power). All are common within the QSFP-DD module and all module voltages are referenced to this potential unless otherwise noted. Connect these directly to the host board signal-common ground plane.
2. VccRx, VccRx1, Vcc1, Vcc2, VccTx and VccTx1 shall be applied concurrently. Requirements defined for the host side of the Host Card Edge Connector are listed in Table 6. VccRx, VccRx1, Vcc1, Vcc2, VccTx and VccTx1 may be internally connected within the module in any combination. The connector Vcc pins are each rated for a maximum current of 1000 mA.
3. All Vendor Specific, Reserved and No Connect pins may be terminated with 50 ohms to ground on the host. Pad 65 (No Connect) shall be left unconnected within the module. Vendor specific and Reserved pads shall have an impedance to GND that is greater than 10 kOhms and less than 100 pF.
4. Plug Sequence specifies the mating sequence of the host connector and module. The sequence is 1A, 2A, 3A, 1B, 2B, 3B. (see Figure 2 for pad locations) Contact sequence A will make, then break contact with additional QSFP-DD pads. Sequence 1A, 1B will then occur simultaneously, followed by 2A, 2B, followed by 3A,3B.

## V. 2-Wires EEPROM Interface

The QSFP-DD passive cable EEPROM is compliant with CMIS3.0 specification. Each connector contains a 256 bytes EEPROM at device address A0(h). The information for addresses 0 to 255 is listed below, see table 3. This information can be tailored to any customer request. Any address can be altered to display customer specific information.

A0h address	Name	Value	Description
0	Identifier	18	Type of Serial Module -- See SFF-8024,19h:OSFP 8X Pluggable Transceiver
1	Version ID	30	the upper nibble is the whole number part and the lower nibble is the decimal part.Example: 21h indicates version 2.1.
	Flat_mem		Upper memory flat or paged.0b=Paged memory 1b=Flat memory (only page 00h implemented)
	CLEI present		CLEI code present in upper page 00h
	Reserved		Reserved
2	TWI Maximum speed	80	Indicates maximum two-wire serial speed supported by module 00b=Module supports up to 400 KHz 01b=Module supports up to 1 MHz 10b=Reserved 11b=Reserved
	Reserved		Reserved
3	Reserved	03	Reserved
	Module state		Current state of Module 001b:ModuleLowPwr state(Flat memory passive cable assemblies)
	Interrupt		Digital state of IntL Interrupt output signal 0b=IntL asserted 1b=IntL not asserted (default)
4~7	Bank 0 lane flag	00	Indicates that one or more of the flag bits from bank 0
8	Reserved	00	Reserved
	Module state changed flag		Indicates change of Module state
9~13	Module Interrupt Flags	00	Module Interrupt Flags
14~25	Module monitors	00	Module monitors Temperature MSB
26~30	Module Global Controls	00	ForceLowPwr,Software Reset,Custom



31~36	Module Level Flag Masks	00	Module Level Flag Masks
37~63	Reserved	00	Reserved
64~84	Custom	00	Custom
85	Module Type Encodings	03	00h:Undefined 01h:Optical Interfaces: MMF 02h:Optical interfaces: SMF 03h:Passive Cu 04h:Active Cable 005:Base-T
86	Module Host Electrical interface codes(ApSel:0001b)	1D	1A:100GBASE-CR4 NRZ 1D:400G CR8 PAM4
87	Module Media interface codes(ApSel:0001b)	01	01:Copper cable
88	Host/Media Lane Count(ApSel:0001b)	88	7-4:Host Lane Count 3-0:Media Lane Count
89	Lane Assignment(ApSel:0001b)	00	code 1:if application is allowed on a given host lane.bits0-7 correspond to host lanes 1-8
90	Module Host Electrical interface codes(ApSel:0010b)	00	Module Host-Media Interface Advertising Codes
91	Module Media interface codes(ApSel:0010b)	00	Module Host-Media Interface Advertising Codes
92	Host/Media Lane Count(ApSel:0010b)	00	Module Host-Media Interface Advertising Codes
93	Lane Assignment(ApSel:0010b)	00	Module Host-Media Interface Advertising Codes
94	Module Host Electrical interface codes(ApSel:0011b)	00	Module Host-Media Interface Advertising Codes
95	Module Media interface codes(ApSel:0011b)	00	Module Host-Media Interface Advertising Codes
96	Host/Media Lane Count(ApSel:0011b)	00	Module Host-Media Interface Advertising Codes
97	Lane Assignment(ApSel:0011b)	00	Module Host-Media Interface Advertising Codes
98	Module Host Electrical interface codes(ApSel:0100b)	00	Module Host-Media Interface Advertising Codes

99	Module Media interface codes(ApSel:0100b)	00	Module Host-Media Interface Advertising Codes
100	Host/Media Lane Count(ApSel:0100b)	00	Module Host-Media Interface Advertising Codes
101	Lane Assignment(ApSel:0100b)	00	Module Host-Media Interface Advertising Codes
102	Module Host Electrical interface codes(ApSel:0101b)	00	Module Host-Media Interface Advertising Codes
103	Module Media interface codes(ApSel:0101b)	00	Module Host-Media Interface Advertising Codes
104	Host/Media Lane Count(ApSel:0101b)	00	Module Host-Media Interface Advertising Codes
105	Lane Assignment(ApSel:0101b)	00	Module Host-Media Interface Advertising Codes
106	Module Host Electrical interface codes(ApSel:0110b)	00	Module Host-Media Interface Advertising Codes
107	Module Media interface codes(ApSel:0110b)	00	Module Host-Media Interface Advertising Codes
108	Host/Media Lane Count(ApSel:0110b)	00	Module Host-Media Interface Advertising Codes
109	Lane Assignment(ApSel:0110b)	00	Module Host-Media Interface Advertising Codes
110	Module Host Electrical interface codes(ApSel:0111b)	00	Module Host-Media Interface Advertising Codes
111	Module Media interface codes(ApSel:0111b)	00	Module Host-Media Interface Advertising Codes
112	Host/Media Lane Count(ApSel:0111b)	00	Module Host-Media Interface Advertising Codes
113	Lane Assignment(ApSel:0111b)	00	Module Host-Media Interface Advertising Codes
114	Module Host Electrical interface codes(ApSel:1000b)	00	Module Host-Media Interface Advertising Codes
115	Module Media interface codes(ApSel:1000b)	00	Module Host-Media Interface Advertising Codes

116	Host/Media Lane Count(ApSel:1000b)	00	Module Host-Media Interface Advertising Codes
117	Lane Assignment(ApSel:1000b)	00	Module Host-Media Interface Advertising Codes
118~125	Password Entry and Change	00	Password Entry and Change
126	Bank Select Byte	00	The module shall ignore the Bank Select byte if the Page Select byte is outside of the 10h to 1Fh range (inclusive).In this case the Bank Select byte shall revert to bank 0 and read/write operations shall be to bank 0.
127	Page Select Byte	00	Writing the value of a non-supported page shall not be accepted by the module. In such cases the Page Select byte shall revert to 0 and read/write operations shall be to upper page 00h.
128	Identifier	18	Identifier Type of Module
129~144	Vendor name	*	Vendor name(ASCII)
145	Vendor OUI	3C	Vendor IEEE company ID
146		18	
147		A0	
148~163	Vendor PN	*	Part number provided by vendor(ASCII)
164	Vendor rev	41	Vendor rev A
165		20	Vendor rev A
166~181	Vendor SN	*	Vendor Serial Number(ASCII)
182~189	Date code	*	Date code(ASCII)
190~199	CLEI code	00	Common Language Equipment Identification code
200	Module Card Power Class	00	000: Power class 1; 001: Power class 2 010: Power class 3; 011: Power class 4 100: Power class 5; 101: Power class 6 110: Power class 7; 111: Power class 8
201	Max Power	06	Maximum power consumption in multiples of 0.25 W rounded up to the next whole multiple of 0.25 W

	Cable assembly Length Lenth multiplier field		Multiplier for value in bits 5-0. 00 = multiplier of .1 01 = multiplier of 1 10 = multiplier of 10 11 = multiplier of 100
	Cable assembly Length Base Length field		Link length base value. To calculate actual link length use multiplier in bits 7-6.
202		*	
203	Media connector Type	23	Type of connector present in the module. See SFF-8024 for codes. 23h: Non-separable Connector
204	Copper cable Attenuation 5GHz	*	Passive copper cable attenuation at 5 GHz in 1 dB increments
205	Copper cable Attenuation 7GHz	*	Passive copper cable attenuation at 7 GHz in 1 dB increments
206	Copper cable Attenuation 12.89GHz	*	Passive copper cable attenuation at 12.89 GHz in 1 dB increments
207	Copper cable Attenuation 25.8GHz	*	Passive copper cable attenuation at 25.8 GHz in 1 dB increments
208	Reserved	00	Reserved
209	Reserved	00	Reserved
210	Near end implementation lane 8	00	0b=Lane 8 implemented in near end 1b=Lane 8 not implemented in near end
211	Reserved	02	Reserved
	Implemented lanes in far end		See Table 27 for config code of discrete far end connectors
212	Media interface technology	0A	0A: Copper cable unequalized
213~220	Reserved	00	Reserved
221	Custom	00	Custom
222	Checksum	*	Include bytes 128-221
223~251	User custom info NV	00	User custom info NV
252~255	User custom info NV	00	User custom info NV

## VI. Bulk Cable Characteristics

The structure of the cable is shown as the figure , the characteristics of the bulk cable are listed below.

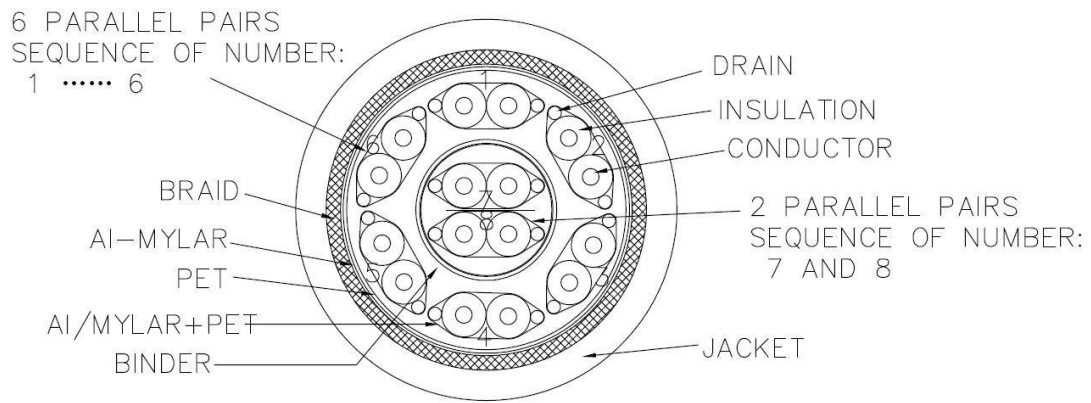

SECTIONAL DRAWING:

1. Voltage rating: 30V
2. Temperature rating: 0 to 70°C
3. Impedance: Differential mode: 100 +5/-5 ohm @TDR
4. Delay Skew(INTRA-SKEW): 30ps/5m max
5. Signal Twin-ax pair cable: Solid Ag plated copper conductor
6. Braid shielding coverage 85% min
7. Jacket material: PVC

### VII. Qualification Requirement Characteristics

ITEM	REQUIREMENT	TEST CONDITION
Differential Impedance Cable Impedance Paddle Card Impedance Cable Termination Impedance	$100 + 10/-5 \Omega$ $100 \pm 10 \Omega$ $100 + 10 / -15 \Omega$	Rise time of 30ps(at the SMA) (20 % - 80 %).
Differential (Input/Output)Return loss SDD11/SDD22	$\text{Return\_loss}(f) \geq \left\{ \begin{array}{ll} 16.5-2\sqrt{f} & 0.05 \leq f < 4.1 \\ 10.66-14\log_{10}(f/5.5) & 4.1 \leq f \leq 19 \end{array} \right\}$ Where f is the frequency in GHz Return loss(f) is the return loss at frequency f	$10\text{MHz} \leq f \leq 26.5\text{GHz}$
Differential to common-mode (Input/Output)Return loss SCD11/SCD22	$\text{Return\_loss}(f) \geq \left\{ \begin{array}{ll} 22-(20/25.78)f & 0.01 \leq f < 12.89 \\ 15-(6/25.78)f & 12.89 \leq f \leq 19 \end{array} \right\}$ Where f is the frequency in GHz Return_loss(f) is the Differential to common-mode return loss at frequency f	$10\text{MHz} \leq f \leq 26.5\text{GHz}$
Common-mode to Common-mode (Input/Output)Return loss SCC11/SCC22	$\text{Return\_loss}(f) \geq 2\text{dB} \quad 0.2 \leq f \leq 19$ Where f is the frequency in GHz Return_loss(f) is the common-mode to common-mode return loss at frequency	$10\text{MHz} \leq f \leq 26.5\text{GHz}$

(Differential InsertionLoss Max. For TPa to TPb Including Test fixture )

$10\text{MHz} \leq f \leq 19\text{GHz}$

Passive Cable : -17.16dB Min. @13.28GHz

Differential Insertion Loss

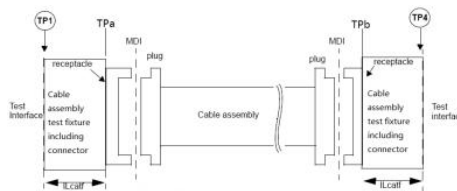

$10\text{MHz} \leq f \leq 26.5\text{GHz}$

Differential to common-mode Conversion Loss-Differential Insertion Loss(SCD21-SDD21)

$$\text{Conversion\_loss}(f) - \text{IL}(f) \geq \begin{cases} 10 & 0.01 \leq f < 12.89 \\ 27 - (29/22)f & 12.89 \leq f < 26.5 \end{cases}$$

Where  
**f** is the frequency in GHz  
**Conversion\_loss(f)** is the cable assembly differential to common-mode conversion loss  
**IL(f)** is the cable assembly insertion loss

10MHz ≤ f ≤ 26.5GHz

ICN	a is the IL@13.28GHz 3 ≤ a ≤ 7.65: 9 mV Max 7.65 ≤ a ≤ 26: 12.75 - 0.49 * a mV Max	10MHz ≤ f ≤ 26.5GHz
-----	--	---------------------

### VIII. Cable Assembly Characteristics

#### QSFP-DD TO QSFP-DD

##### Exploded View

- 1.Bot Back Shell
- 2.PCBA(QDD)
- 3.SUS304 LATCH
- 4.Top Back Shell
- 5.Copper foil
- 6.Pull Tap
- 7.Spring
- 8.Raw Cable
- 9.Lock LATCH
- 10.Rivet

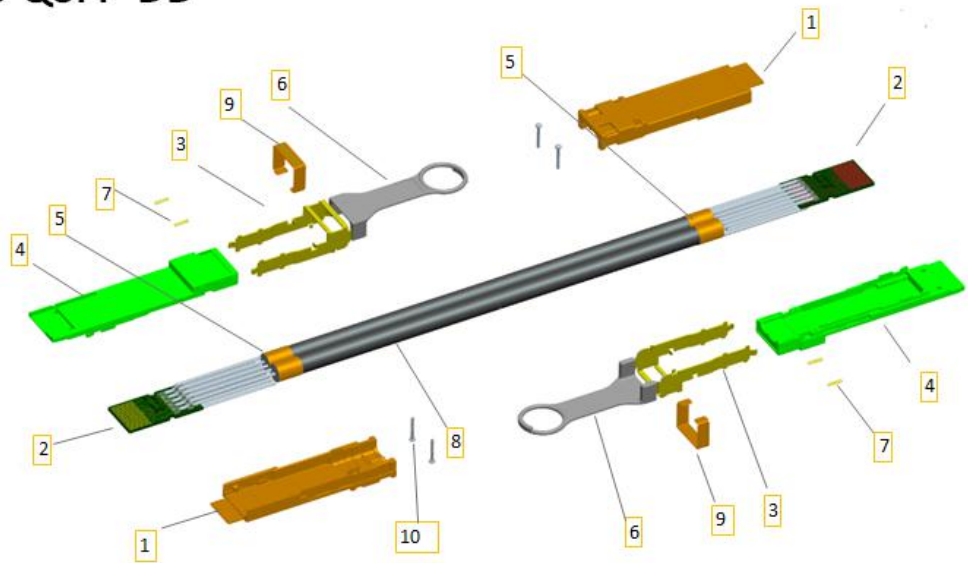

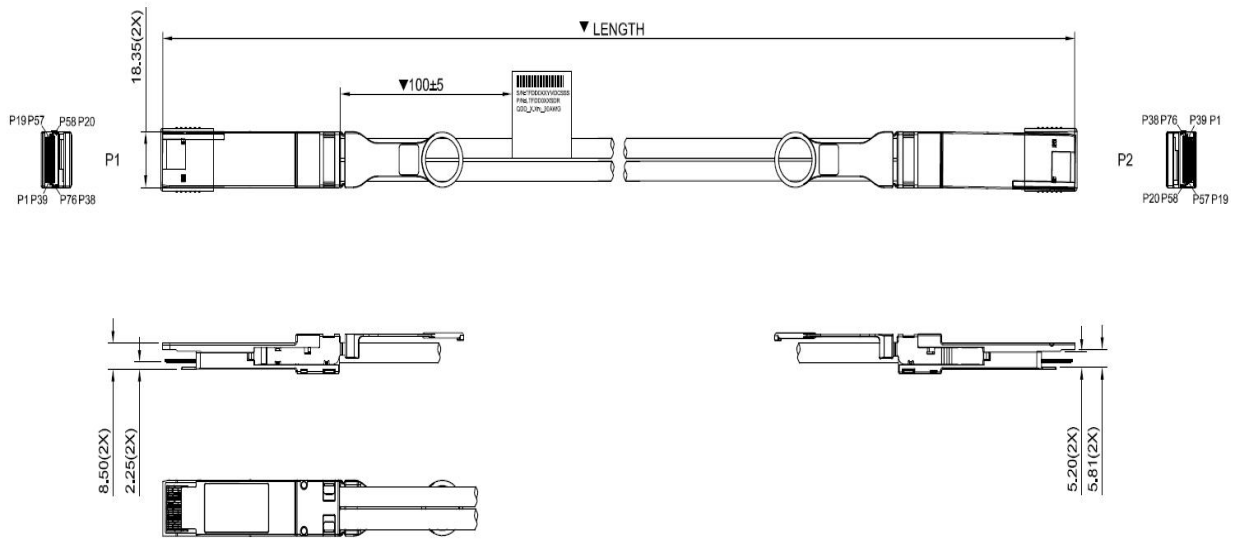
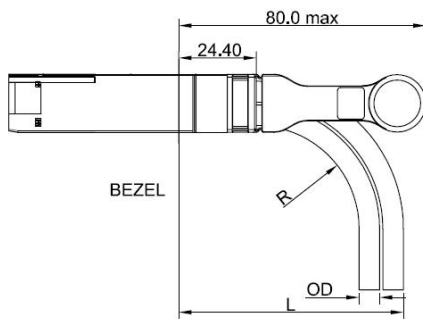
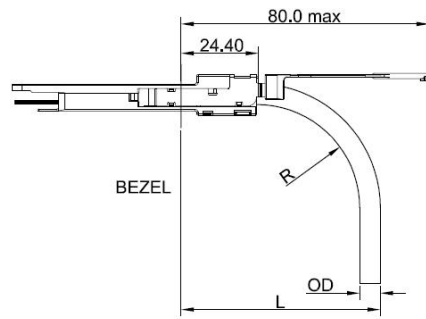

Figure 1 QSFP-DD to QSFP-DD Mechanical Structure

## QSFP-DD 30AWG



QSFP-DD Horizontal Direction			
CABLE GAUGE	DIAMETER "OD"	MIN.BEND RADIUS "R"	MIN.BEND SPACE "L"
30AWG	6.7MM	33.5MM	72MM



QSFP-DD Vertical Direction			
CABLE GAUGE	DIAMETER "OD"	MIN.BEND RADIUS "R"	MIN.BEND SPACE "L"
30AWG	6.7MM	33.5MM	65MM



### QSFP-DD 28AWG

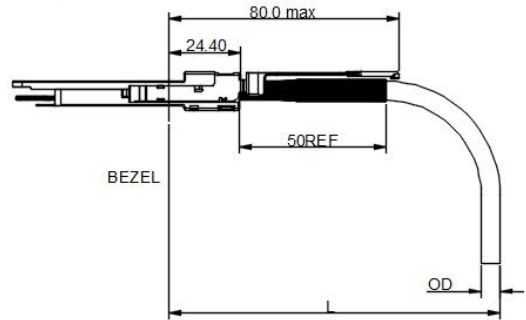
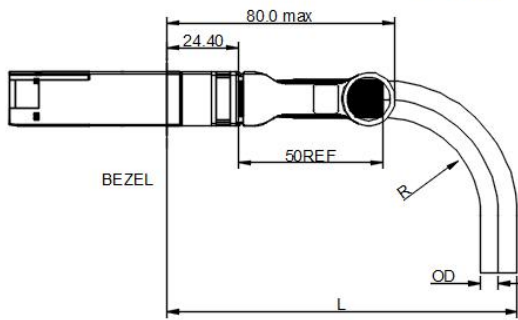

QSFP-DD Horizontal Direction			
CABLE GAUGE	DIAMETER "OD"	MIN. BEND RADIUS "R"	MIN. BEND SPACE "L"
28AWG	7.9MM	39.5MM	130MM

QSFP-DD Vertical Direction			
CABLE GAUGE	DIAMETER "OD"	MIN. BEND RADIUS "R"	MIN. BEND SPACE "L"
28AWG	7.9MM	39.5MM	122MM

### QSFP-DD 26AWG

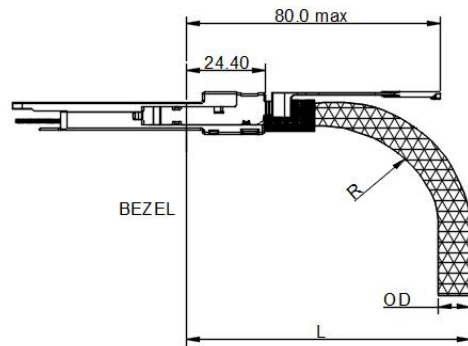
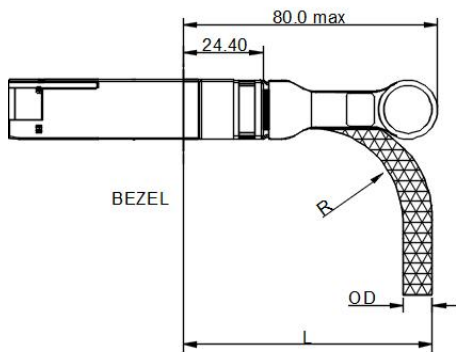

QSFP-DD Horizontal Direction			
CABLE GAUGE	DIAMETER "OD"	MIN. BEND RADIUS "R"	MIN. BEND SPACE "L"
26AWG	11.4MM	55MM	105MM

QSFP-DD Vertical Direction			
CABLE GAUGE	DIAMETER "OD"	MIN. BEND RADIUS "R"	MIN. BEND SPACE "L"
26AWG	11.4MM	55MM	105MM

Figure 2 Horizontal and Vertical Bend Radius

## Test Center

FS.COM transceivers are tested to ensure connectivity and compatibility in our test center before shipped out. FS.COM test center is supported by a variety of mainstream original brand switches and groups of professional staff, helping our customers make the most efficient use of our products in their systems, network designs and deployments.

The original switches could be found nowhere but at FS.COM test center, eg: Juniper MX960 & EX 4300 series, Cisco Nexus 9396PX & Cisco ASR 9000 Series, HP 5900 Series & HP 5406R ZL2 V3(J9996A), Arista 7050S-64, Brocade ICX7750-26Q & ICX6610-48, Avaya VSP 7000 MDA 2, etc.



Cisco ASR 9000 Series(A9K-MPA-1X40GE)



ARISTA 7050S-64(DCS-7050S-64)



Juniper MX960



Brocade ICX 7750-26Q



Extreme Networks X670V VIM-40G4X



Mellanox M3601Q



Dell N4032F



HP 5406R ZL2 V3(J9996A)



AVAYA 7024XLS(7002QQ-MDA)

## Test Assured Program

FS.COM truly understands the value of compatibility and interoperability to each optics. Every module FS.COM provides must run through programming and an extensive series of platform diagnostic tests to prove its performance and compatibility. In our test center, we care of every detail from staff to facilities—professionally trained staff, advanced test facilities and comprehensive original-brand switches, to ensure our customers to receive the optics with superior quality.



Our smart data system allows effective product management and quality control according to the unique serial number, properly tracing the order, shipment and every part.



With a comprehensive line of original-brand switches, we can recreate an environment and test each optics in practical application to ensure quality and distance.

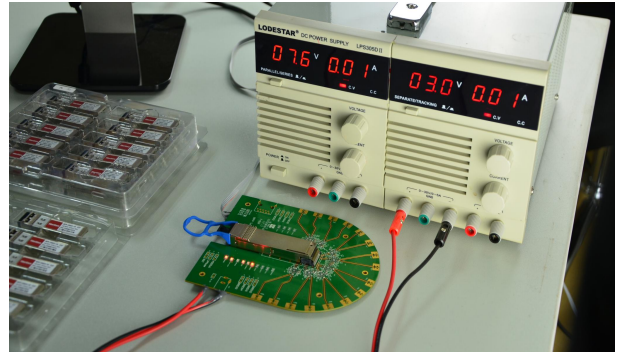

Our in-house coding facility programs all of our parts to standard OEM specs for compatibility on all major vendors and systems such as Cisco, Juniper, Brocade, HP, Dell, Arista and so on.



The last test assured step to ensure our products to be shipped with perfect package.

## Order Information

Part Number	Data Rate	Length	Wire Gauge	Connector Type	Temp. Range	Cable Jacket
QSFP-DD-PC01	Up to 400G	1m	AWG30	Passive Copper	0-70°C	PVC
QSFP-DD-PC02	Up to 400G	2m	AWG28	Passive Copper	0-70°C	PVC
QSFP-DD-PC03	Up to 400G	3m	AWG28	Passive Copper	0-70°C	PVC



 <https://www.fs.com>



The information in this document is subject to change without notice. FS has made all efforts to ensure the accuracy of the information, but all information in this document does not constitute any kind of warranty.