

25GBASE-LR SFP28 1310nm 10km Industrial DOM Transceiver

SFP28-25GLR-31-I



Application

- 25GBASE-LR
- CPRI Option 10/e CPRI

Standards

- SFF-8472
- SFF-8402
- SFF-8432
- SFF-8431
- CEI-28G-VSR

Features

- Up to 10 km Transmission Distance
- Low Power Consumption <1.2W
- Single 3.3V ± 5% Power Supply
- LC-duplex Connector
- -40°C to 85°C Operating Case Temperature Range
- Compliant with SFF-8472

Description

25G LR-I is a 1310nm DFB laser based 25Gb/s SFP28 transceiver. It is designed to transmit and receive optical data up to 10km over single mode fiber. The transceiver is compliant with SFF-8472, SFF-8402, SFF-8432 and applicable portions of SFF-8431. Digital diagnostics functions are available via a 2-wire serial interface, as specified in SFF- 8472.

I. Absolute Maximum Ratings

Parameter	Symbol	Unit	Min	Max
Storage Temperature Range	T_S	°C	-45	85
Relative Humidity	RH	%	0	95
Supply Voltage	V_{CC}	V	-0.3	3.6

II. Recommended Operating Conditions

Parameter	Symbol	Unit	Min.	Typ.	Max.
Operating Case Temperature Range	T_C	°C	-40		85
Power Supply Voltage	V_{CC}	V	3.14	3.3	3.46
Bit Rate	BR	Gb/s		25.78125	
Max Supported Link Length	L	km			10

III. Electrical Characteristics

Parameter	Symbol	Unit	Min.	Typ.	Max.	Note
Supply Voltage	V_{CC}	V	3.14	3.3	3.46	
Transmitter						
Input Differential Impedance	R_{IN}	Ω		100		
Single Ended Data Input Swing	V_{IN}	mVp-p	90		450	
Transmit Disable Voltage	V_{DIS}	V	2		$V_{CCHOST}+0.3$	
Transmit Enable Voltage	V_{EN}	V	V_{EE}		$V_{EE}+0.8$	
Transmit Fault Assert Voltage	V_{FA}	V	2.4		$V_{CCHOST}+0.3$	
Transmit Fault De-Assert Voltage	V_{FDA}	V	V_{EE}		$V_{EE}+0.4$	
Receiver						
Single Ended Data Output Swing	V_{OD}	mVp-p	225		450	
LOS Fault	V_{LOSFT}	V	2.2		$V_{CCHOST}+0.3$	
LOS Normal	V_{LOSNR}	V	V_{EE}		$V_{EE}+0.4$	

IV. Optical Transmitter/Receiver Characteristics

Parameter	Symbol	Unit	Min.	Typ.	Max.	Note
Transmitter						
Center Wavelength	λ	nm	1295	1310	1325	
Side Mode Suppression Ratio	SMSR	dB	30			
Optical Modulation Amplitude	P_{OMA}	dBm	-4		2.2	
Optical Output Power	P_{avg}	dBm	-4.5		2	
Extinction Ratio	ER	dB	3.5			
Transmitter and Dispersion Penalty	TDP	dB			2.7	
Average Launch Power of OFF Transmitter	P_{OFF}	dBm			-30	
Receiver						
Center Wavelength	λ	nm	1260	1310	1360	
Overload		dBm	2			
Receiver Power(OmA)	P_{OMA}	dBm			-11.4	1
Assert LOS	LOS_A	dBm	-30			
De-Assert LOS	LOS_D	dBm			-15	
LOS Hysteresis		dB	0.5			

Note 1: Measured with 25.78125Gb/s, PRBS 2³¹-1, NRZ, ER>4dB

(tested under recommended operating conditions, unless otherwise noted)

V. Pin Configuration

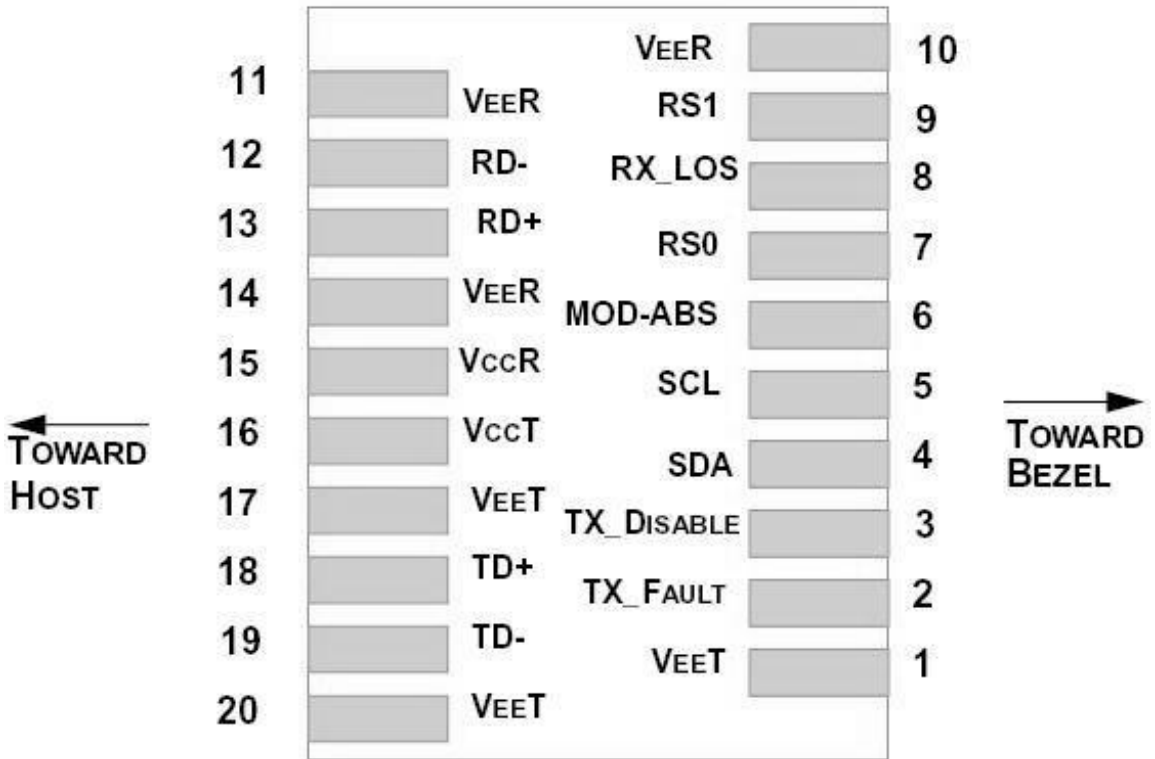

VI. Transceiver Pin Descriptions

Pin No.	Symbol	Logic	Description
1,17,20	$V_{EE}T$		Connected to signal ground on the host board
2	TX Fault	LVTTTL Output	Module transmitter fault output
3	TX Disable	LVTTTL Input	Module transmitter disable control
4	SDA	LVTTTL Input/Output	2-wire serial interface data
5	SCL	LVTTTL Input/Output	2-wire serial interface clock
6	MOD-ABS		Module absent (connected to Module ground)
7	RS0	LVTTTL Input	Rate select 0 (Rx) :Low=CDR Bypass ; High=CDR Select
8	LOS	LVTTTL Output	Receiver loss of signal
9	RS1	LVTTTL Input	Rate select 1 (Tx) :Low=CDR Bypass ; High=CDR Select
10,11,14	$V_{EE}R$		Connected to signal ground on the host board.
12	RD-	CML Output	Receiver inverted data output, internally AC coupled and terminated
13	RD+	CML Output	Receiver non-inverted data output, internally AC coupled and terminated.
15	$V_{CC}R$		Receiver Power 3.3V Supply
16	$V_{CC}T$		Transmitter Power 3.3V Supply
18	TD+	CML Input	Transmitter non-inverted data input, internally AC coupled and terminated.
19	TD-	CML Input	Transmitter inverted data Input, internally AC coupled and terminated.

VII. Principle Diagram

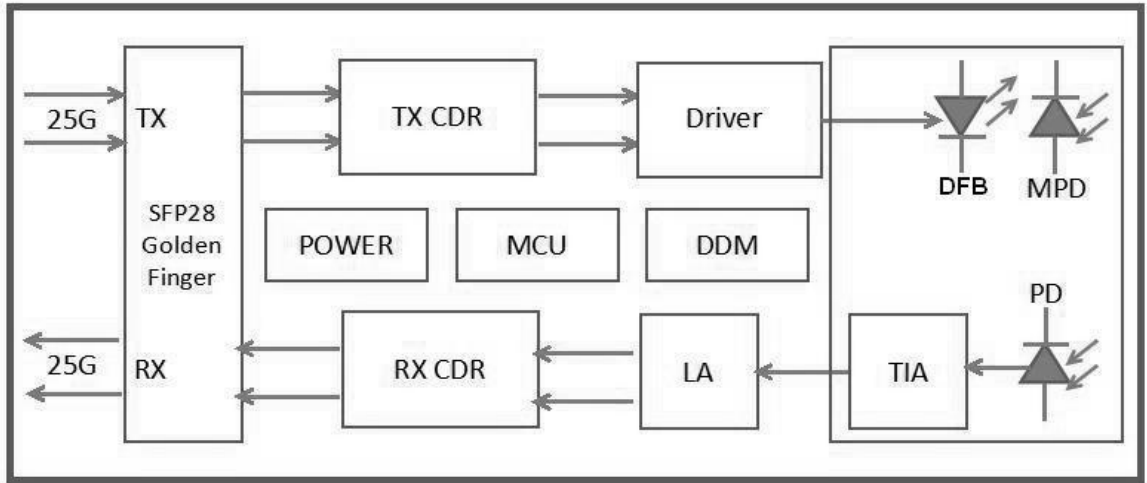

VIII. Mechanical Dimensions

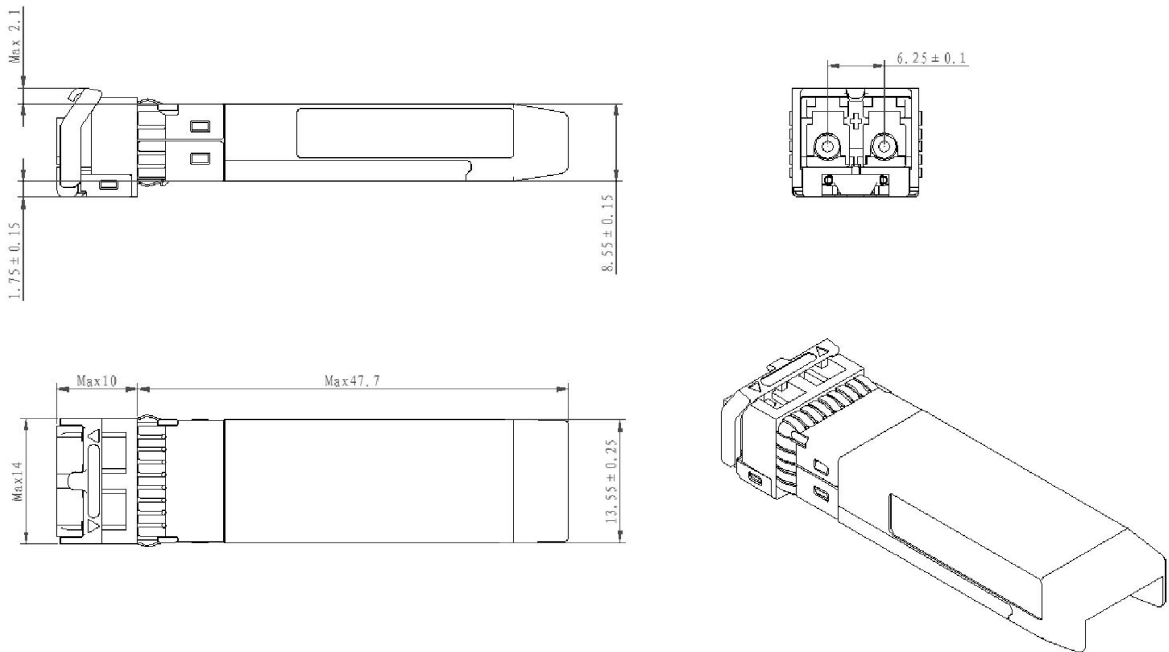

UNIT:mm

Test Center

I. Compatibility Testing

Each fiber optical transceiver has been tested in host device on site in FS Assured Program to ensure full compatibility with over 200 vendors.



Cisco Catalyst C9500-24Y4C

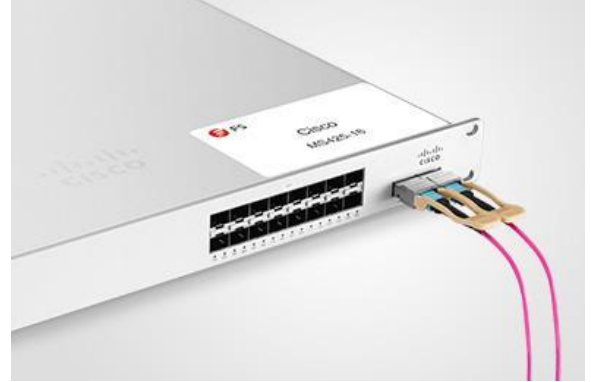

Cisco MS425-16

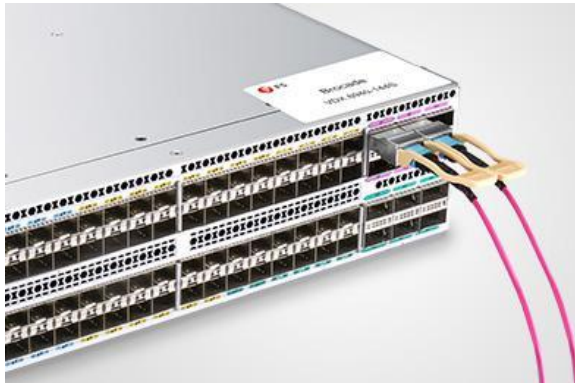

Brocade VDX 6940-144S



Dell EMC Networking Z9100-ON



Force10 S60-44T



HUAWEI S6720-30L-HI-24S

Above is part of our test bed network equipment. For more information, please click the Test Bed PDF. It will be updated in real time as we expand our portfolio.

II. Performance Testing

Each fiber optical transceiver has been fully tested in FS Assured Program equipped with world's most advanced analytical equipment to ensure that our transceivers work perfectly on your device.

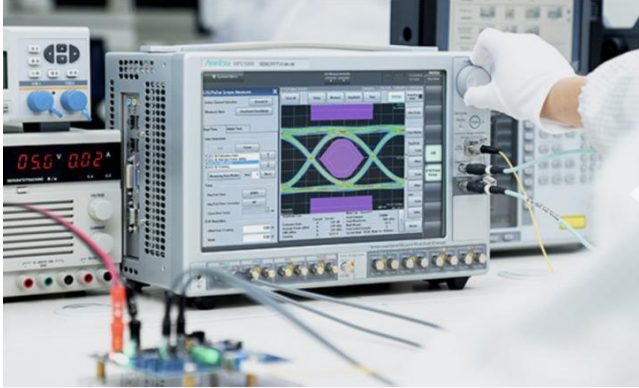

1. TX/RX Signal Quality Testing

Equipped with the all-in-one tester integrated 4ch BERT & sampling oscilloscope, and variable optical attenuator to ensure the input and output signal quality.

- Eye Pattern Measurements: jitter, Mask Margin, etc
- Average Output Power
- OMA
- Extinction Ratio
- Receiver Sensitivity
- BER Curve

2. Reliability and Stability Testing

Subject the transceivers to dramatic changes in temperature on the thermal shock chamber to ensure reliability and stability of the transceivers.

- Commercial: 0 °C to 70 °C
- Extended: -5 °C to 85 °C
- Industrial: -40 °C to 85 °C



3. Transfer Rate and Protocol Testing

Test the actual transfer data rate and the transmission ability under different protocols with Network Master Pro.

- Ethernet
- Fibre Channel
- SDH/SONET
- CPRI



4. Optical Spectrum Evaluation

Evaluate various important parameters with the Optical Spectrum Analyzer to meet the industry standards.

- Center Wavelength, Level
- OSNR
- SMSR
- Spectrum Width

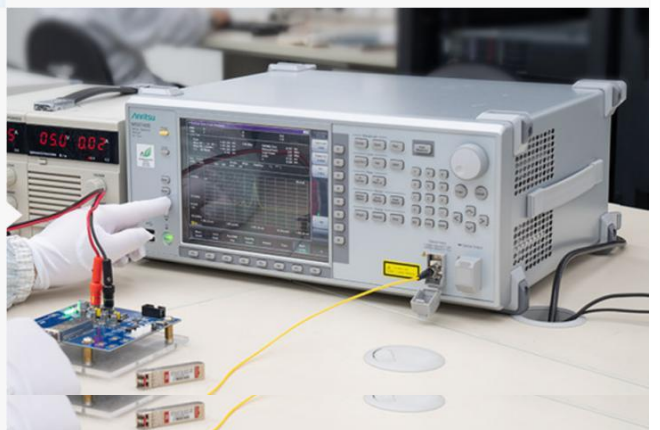

Ordering Information

Part Number	Description
SFP28-25GSR-85	25G SFP28 850nm 100m DOM TFP28-25GSR-85
SFP28-25GLR-31	25G SFP28 1310nm 10km DOM Transceiver
SFP28-25GER-31	25G SFP28 1310nm 30km DOM Transceiver
SFP28-25GER-31	25G SFP28 1310nm 40km DOM Transceiver
SFP28-25GSR-85-I	25G SFP28 850nm 100m Industrial DOM Transceiver
SFP28-25GLR-31-I	25G SFP28 1310nm 10km Industrial DOM Transceiver
SFP28-25GER-31-I	25G SFP28 1310nm 30km Industrial DOM Transceiver
SFP28-25GER-31-I	25G SFP28 1310nm 40km Industrial DOM Transceiver



 <https://www.fs.com>



The information in this document is subject to change without notice. FS has made all efforts to ensure the accuracy of the information, but all information in this document does not constitute any kind of warranty.