

25G LWDM SFP28 1286.66nm-1309.14nm 40km DOM Transceiver

LWDM-SFP25G-40



Application

- High-speed storage area networks
- Computer cluster cross-connect
- Custom high-speed data pipes
- Inter Rack Connection
- WDM System

Features

- 25.78Gb/s bit rates
- Hot-Pluggable
- EML transmitter, APD photo-detector
- Up to 40km on SMF
- Operating case temperature Range: 0~70° C
- 2-wire interface for management specifications compliant with SFF 8472 digital diagnostic monitoring interface for optical transceivers
- Duplex LC connector
- Power Supply :+3.3V
- Cost effective SFP28 solution, enables higher port densities and greater bandwidth
- Low Power consumption<1.5W
- RoHS compliant

Description

FS's 25G LWDM is a very compact optical transceiver module converts 25Gbit/s serial CML electrical data into serial optical data compliant with the 25GBASE-ER standard. The EML transmitter and APD receiver provide superior performance for Ethernet applications at up to 40km links on SMF. The SFP28 ER Module compliant with SFF-8431, SFF-8432 and IEEE 802.3CC 25GBASE-ER. Digital diagnostics functions are available via a 2-wire serial interface, as specified in SFF-8472. The fully SFP28 compliant form factor provides hot pluggability, easy optical port upgrades and low EMI emission.

Product Specifications

I. Absolute Maximum Ratings

Parameter	Symbol	Min	Typ.	Max	Unit	Ref.
Storage Temperature	T_S	-40		+85	°C	
Case Operating Temperature	T_A	0		70	°C	
Maximum Supply Voltage	V_{CC}	0		3.6	V	
Relative Humidity	RH	5		95	%	

II. Electrical Characteristics ($T_{OP} = 0$ to 70 ° C, $V_{CC} = 3.135$ to 3.465 Volts)

Parameter	Symbol	Min	Typ.	Max	Unit	Ref.
Supply Voltage	V_{CC}	3.135		3.465	V	
Supply Current	I_{CC}			606	mA	
Power Consumption	P			2	W	
Data Rate	R		25.78		Gb/s	

Transmitter Section:

Input differential impedance	R_{in}		100		Ω	1
Tx Input Single Ended DC Voltage Tolerance (Ref VeeT)	V	-0.3		4	V	

Differential input voltage swing	$V_{in,pp}$	180		700	mV	2
Transmit Disable Voltage	V_D	2		V_{cc}	V	
Transmit Enable Voltage	V_{EN}	Vee		Vee+0.8	V	
Receiver Section:						
Single Ended Output Voltage Tolerance	V	-0.3		4	V	
Rx Output Diff Voltage	V_o	150		900	mV	
Rx Output Rise and Fall Time	T_r/T_f	9.5			ps	3
LOS Fault	$V_{LOS\ fault}$	2		V_{CCHOST}	V	4
LOS Normal	$V_{LOS\ norm}$	Vee		Vee+0.8	V	4

Notes:

- 1.Connected directly to TX data input pins. AC coupling from pins into laser driver IC.
- 2.Per SFF-8431 Rev 3.0
- 3.20%~80%
- 4.LOS is an open collector output. Should be pulled up with 4.7k – 10k Ω on the host board. Normal operation is logic 0; loss of signal is logic 1. Maximum pull-up voltage is 5.5V.

III. Optical Characteristics (TOP = 0 to 70° C, VCC = 3.135 to 3.465 Volts)

Parameter	Symbol	Min	Typ.	Max	Unit	Ref.
Transmitter Section:						
Center Wavelength	λ_t	1285.51	1286.66	1287.81	nm	
		1289.95	1291.10	1292.25		
		1294.41	1295.56	1296.71		
		1298.90	1300.05	1301.20		
		1303.43	1304.58	1305.73		
		1307.99	1309.14	1310.29		

spectral width	$\Delta\lambda$			1	nm	
Average Optical Power	P_{avg}	-2.0		+6	dBm	1
Laser Off Power	P_{off}			-30	dBm	
Extinction Ratio	ER	4			dB	
Receiver Section:						
Center Wavelength	λ_r	1295		1325	nm	
Receiver Sensitivity(OMA)	Sen			-19	dBm	2
Stressed Sensitivity(OMA)	Sen_2			-16.5	dBm	2
Los Assert	LOS_A	-30			dBm	
Los Dessert	LOS_D			-20	dBm	
Los Hysteresis	LOS_H	0.5		5	dB	
Overload	Sat	-6			dBm	3
Receiver Reflectance	Rrx			-12	dB	

Notes:

- 1.Average power figures are informative only, per IEEE802.3CC.
- 2.Conditions of stressed receiver tests per IEEE802.3CC. At 5E-5 BER.
- 3.Receiver overload specified in OMA and under the worst comprehensive stressed condition.

IV. Timing Characteristics

Parameter	Symbol	Min	Typ.	Max	Unit
TX_Disable Assert Time	t_{off}			100	us
TX_Disable Negate Time	t_{on}			2	ms

Time to Initialize Include Reset of TX_FAULT	t_int			300	ms
TX_FAULT from Fault to Assertion	t_fault			1	ms
TX_Disable Time to Start Reset	t_reset	10			us
Receiver Loss of Signal Assert Time	T _A ,RX_LOS			100	us
Receiver Loss of Signal Deassert Time	T _d ,RX_LOS			100	us
Rate-Select Chage Time	t_ratesel			10	us
Serial ID Clock Time	t_serial-clock			100	kHz

V. Digital Diagnostic Monitoring Information

Data Address	Parameter	Accuracy	Unit
96-97	Transceiver Internal Temperature	± 3.0	°C
98-99	VCC3 Internal Supply Voltage	± 3.0	%
100-101	Laser Bias Current	± 10	%
102-103	Tx Output Power	± 2.0	dBm
104-105	Rx Input Power	± 2.0	dBm

VI. Pin Assignment

Pin	Name	Function	Notes
1	VeeT	Module transmitter ground	1
2	Tx Fault	Module transmitter fault	2
3	Tx Disable	Transmitter Disable; Turns off transmitter laser output	3
4	SDL	2 wire serial interface data input/output (SDA)	4
5	SCL	2 wire serial interface clock input (SCL)	4
6	MOD-ABS	Module Absent, connect to VeeR or VeeT in the module	2

7	RS0	Rate select0, optionally control SFP+ receiver. When high, input data rate >4.5Gb/ s; when low, input data rate <=4.5Gb/s	
8	LOS	Receiver Loss of Signal Indication	
9	RS1	Rate select0, optionally control SFP+ transmitter. When high, input data rate >4.5Gb/s; when low, input data rate <=4.5Gb/s	
10	VeeR	Module receiver ground	1
11	VeeR	Module receiver ground	1
12	RD-	Receiver inverted data out put	
13	RD+	Receiver non-inverted data out put	
14	VeeR	Module receiver ground	1
15	VccR	Module receiver 3.3V supply	
16	VccT	Module transmitter 3.3V supply	
17	VeeT	Module transmitter ground	1
18	TD+	Transmitter non-inverted data out put	
19	TD-	Transmitter inverted data out put	
20	VeeT	Module transmitter ground	1

Notes:

- 1.The module ground pins shall be isolated from the module case.
- 2.This pin is an open collector/drain output pin and shall be pulled up with 4.7K-10Kohms to Host_Vcc on the host board.
- 3.This pin shall be pulled up with 4.7K-10Kohms to VccT in the module.
- 4.This pin is an open collector/drain output pin and shall be pulled up with 4.7K-10Kohms to Host_Vcc on the host board.

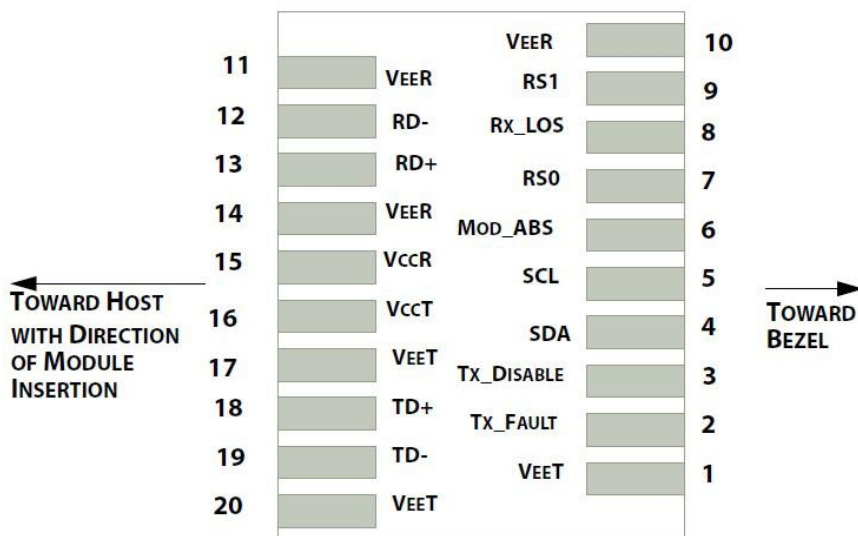

Diagram of Host Board Connector Block Pin Numbers and Name

VII. SFP28 Module EEPROM Information and Management

The SFP28 modules implement the 2-wire serial communication protocol as defined in the SFF -8472. The serial ID information of the SFP28 modules and Digital Diagnostic Monitor parameters can be accessed through the I²C interface at address A0h and A2h.

The memory is mapped in Table 1.

Detailed ID information (A0h) is listed in Table 2.

And the DDM specification at address A2h.

For more details of the memory map and byte definitions, please refer to the SFF-8472, “Digital Diagnostic Monitoring Interface for Optical Transceivers”. The DDM parameters have been internally calibrated.

Digital Diagnostic Memory Map (Specific Data Field Descriptions)

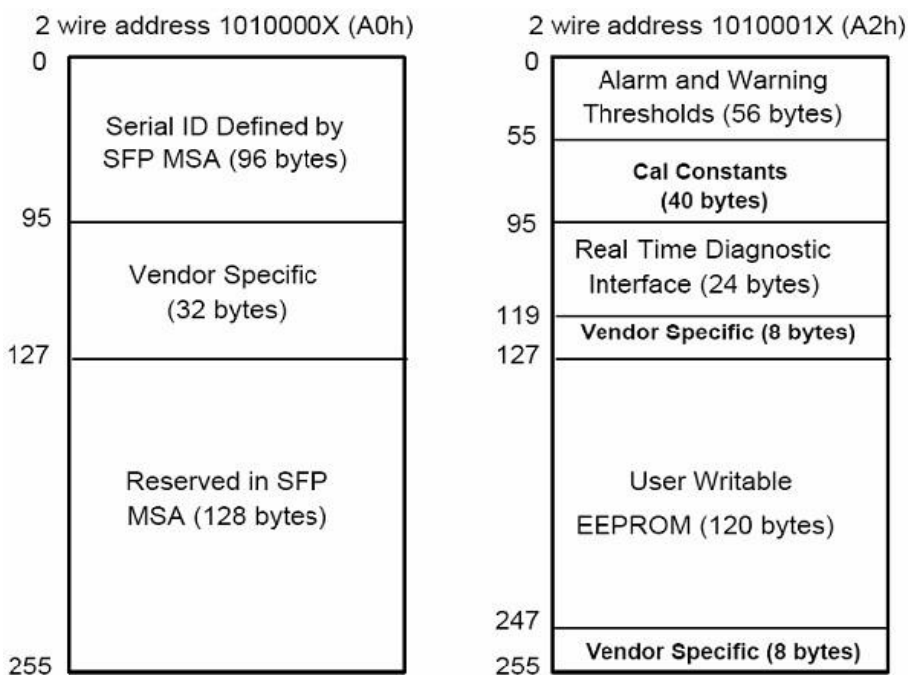

EEPROM Serial ID Memory Contents (A0h)

Data Address	Length (Byte)	Name of Length	Description and Contents
Base ID Fields			
0	1	Identifier	Type of Serial transceiver (03h=SFP)
1	1	Reserved	Extended identifier of type serial transceiver (04h)
2	1	Connector	Code of optical connector type (07=LC)
3-10	8	Transceiver	25G Base-ER
11	1	Encoding	64B/66B

12	1	BR, Nominal	Nominal baud rate, unit of 100Mbps
13-14	2	Reserved	(0000h)
15	1	Length(9um)	Link length supported for 9/125um fiber, units of 100m
16	1	Length(50um)	Link length supported for 50/125um fiber, units of 10m
17	1	Length(62.5um)	Link length supported for 62.5/125um fiber, units of 10m
18	1	Length(Copper)	Link length supported for copper, units of meters
19	1	Reserved	
20-35	16	Vendor Name	SFP vendor name: FS
36	1	Reserved	
37-39	3	Vendor OUI	SFP transceiver vendor OUI ID
40-55	16	Vendor PN	Part Number: "" (ASCII)
56-59	4	Vendor rev	Revision level for part number
60-62	3	Reserved	
63	1	CCID	Least significant byte of sum of data in address 0-62
Extended ID Fields			
64-65	2	Option	Indicates which optical SFP signals are implemented (001Ah = LOS, TX_FAULT, TX_DISABLE all supported)
66	1	BR, max	Upper bit rate margin, units of %
67	1	BR, min	Lower bit rate margin, units of %
68-83	16	Vendor SN	Serial number (ASCII)
84-91	8	Date code	FS's Manufacturing date code
92-94	3	Reserved	
95	1	CCEX	Check code for the extended ID Fields (addresses 64 to 94)
Vendor Specific ID Fields			
96-127	32	Readable	FS specific date, read only
128-255	128	Reserved	Reserved for SFF-8079

VIII. Regulatory Compliance

The 25G LWDM complies with international Electromagnetic Compatibility (EMC) and international safety requirements and standards (see details in Table following).

Electrostatic Discharge (ESD) to the Electrical Pins	MIL-STD-883E Method 3015.7	Class 1(>1000 V)
Electrostatic Discharge (ESD) to the Duplex LC Receptacle	IEC 61000-4-2 GR-1089-CORE	Compatible with standards
Electromagnetic Interference (EMI)	FCC Part 15 Class B EN55022 Class B (CISPR 22B) VCCI Class B	Compatible with standards
Laser Eye Safety	FDA 21CFR 1040.10 and 1040.11 EN60950, EN (IEC) 60825-1,2	Compatible with Class 1 laser product.

IX. Revision History

Revision	RELEASE DATE	CHANGE	Author
1.0	May 5, 2019	Initial release	FEI.LIAO

X. Recommended Circuit

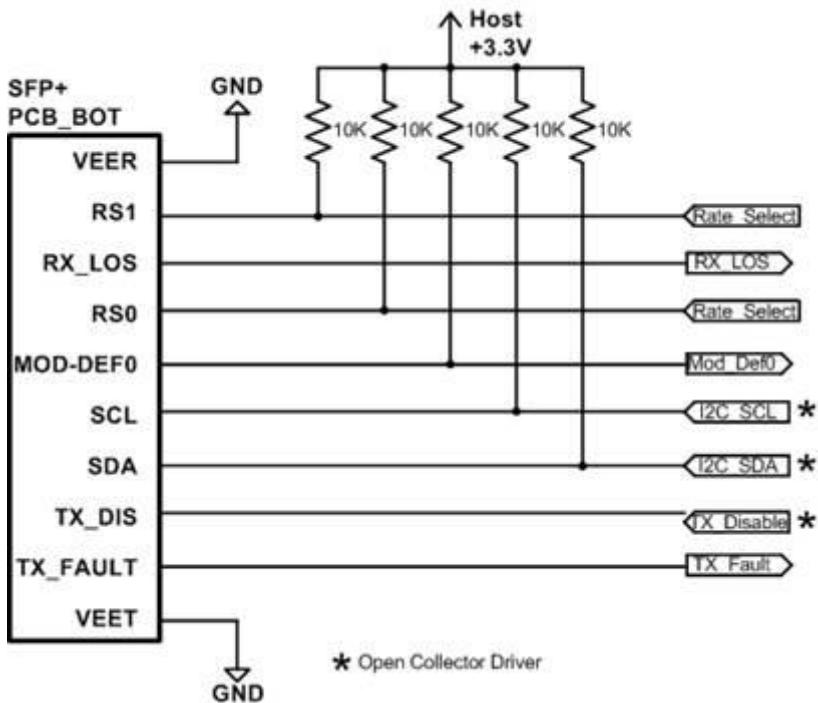
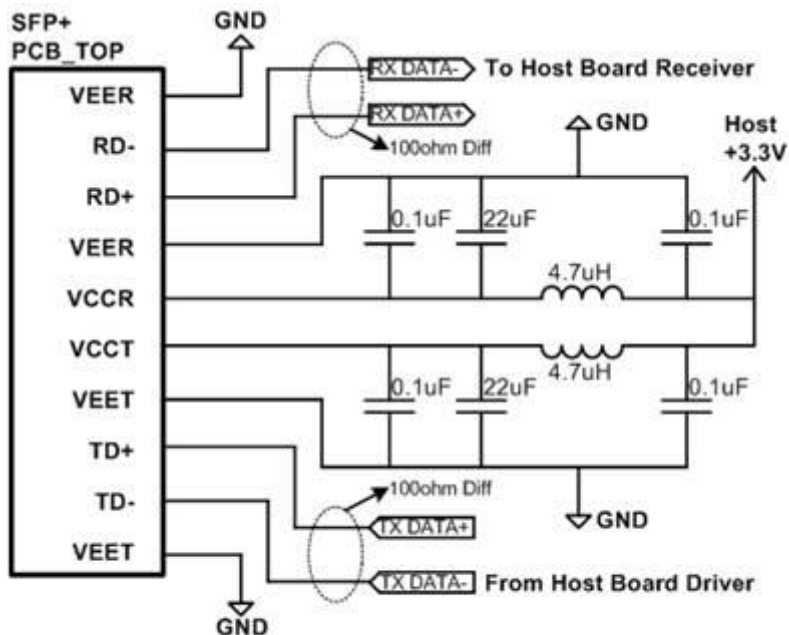

Recommended High-speed Interface Circuit

XI. Transceiver Block Diagram

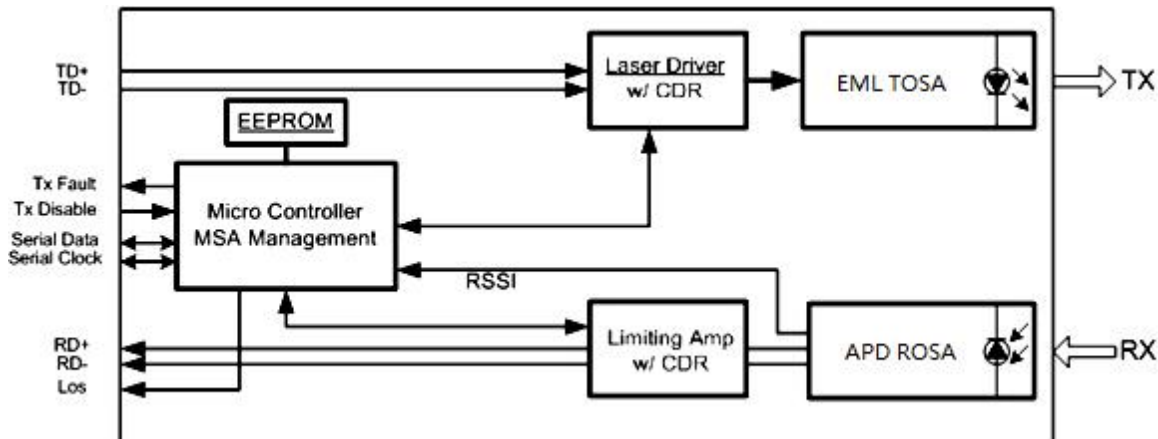

XII. Diagram Mechanical Drawing

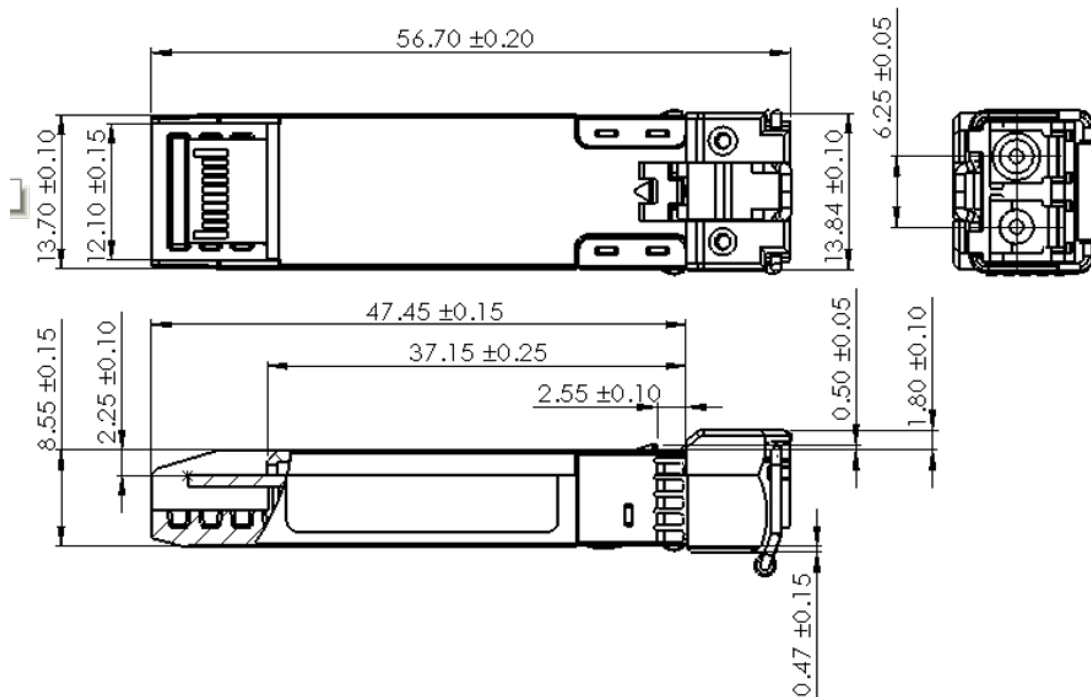

Test Center

FS.COM transceivers are tested to ensure connectivity and compatibility in our test center before shipped out. FS.COM test center is supported by a variety of mainstream original brand switches and groups of professional staff, helping our customers make the most efficient use of our products in their systems, network designs and deployments.

The original switches could be found nowhere but at FS.COM test center, eg: Juniper MX960 & EX 4300 series, Cisco Nexus 9396PX & Cisco ASR 9000 Series, HP 5900 Series & HP 5406R ZL2 V3(J9996A), Arista 7050S-64, Brocade ICX7750-26Q & ICX6610-48, Avaya VSP 7000 MDA 2, etc.



Cisco ASR 9000 Series(A9K-MPA-1X40GE)



ARISTA 7050S-64(DCS-7050S-64)



Juniper MX960



Brocade ICX 7750-26Q



Extreme Networks X670V VIM-40G4X



Mellanox M3601Q



Dell N4032F



HP 5406R ZL2 V3(J9996A)



AVAYA 7024XLS(7002QQ-MDA)

Test Assured Program

FS.COM truly understands the value of compatibility and interoperability to each optics. Every module FS.COM provides must run through programming and an extensive series of platform diagnostic tests to prove its performance and compatibility. In our test center, we care of every detail from staff to facilities—professionally trained staff, advanced test facilities and comprehensive original-brand switches, to ensure our customers to receive the optics with superior quality.



Our smart data system allows effective product management and quality control according to the unique serial number, properly tracing the order, shipment and every part.

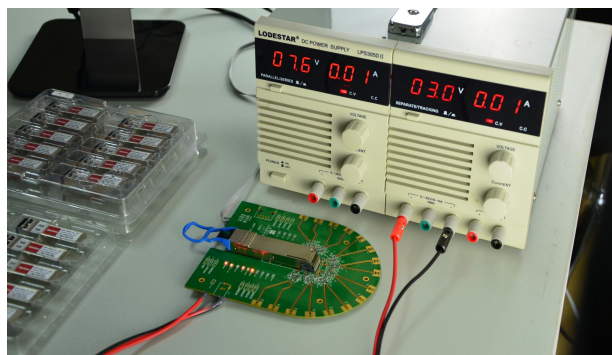

Our in-house coding facility programs all of our parts to standard OEM specs for compatibility on all major vendors and systems such as Cisco, Juniper, Brocade, HP, Dell, Arista and so on.



With a comprehensive line of original-brand switches, we can recreate an environment and test each optics in practical application to ensure quality and distance.



The last test assured step to ensure our products to be shipped with perfect package.

Order Information

Part Number	Description
CWDM-SFP25G-10SP	25GBASE CWDM SFP28 1270-1370NM 10KM DOM TRANSCEIVER
CWDM-SFP25G-10M	25GBASE CWDM SFP28 1470-1570NM 10KM DOM TRANSCEIVER
CWDM-SFP25G-40S	25GBASE CWDM SFP28 1270-1370NM 40KM DOM TRANSCEIVER
DWDM-SFP25G-10	25GBASE DWDM SFP28 C17-C61 10KM DOM TRANSCEIVER
LWDM-SFP25G-40	25GBASE LWDM SFP28 1286.66-1309.14NM 40KM DOM TRANSCEIVER



 <https://www.fs.com>



The information in this document is subject to change without notice. FS has made all efforts to ensure the accuracy of the information, but all information in this document does not constitute any kind of warranty.