

10GBASE-LRM SFP+ 1310nm 220m DOM Transceiver

SFP-10GLRM-31



Application

- 10GBASE-LRM 10G Ethernet
- Legacy FDDI multimode links

Features

- Hot-pluggable SFP+ footprint
- Supports 10.3 Gb/s bit rates
- Power dissipation < 1W
- RoHS-6 compliant (lead-free)
- Commercial temperature range 0° C to 70° C
- Single 3.3V power supply
- Maximum link length of 220m
- Uncooled directly modulated
- Fabry-Perot (FP) laser at 1310nm
- Receiver linear electrical interface
- Duplex LC connector
- Built-in digital diagnostic functions

Description

10Gb/s Enhanced Small Form Factor Pluggable SFP+ transceivers are designed for use in 10-Gigabit Ethernet links up to 220m over Multi Mode fiber. They are compliant with SFF-8431, SFF-8432 and IEEE 802.3 aq 10GBASE-LRM. Digital diagnostics functions are available via a 2-wire serial interface, as specified in SFF-8472 .

The transceiver is a “linear module” i.e. it employs a linear receiver. Host board designers using an EDC PHY IC should follow the IC manufacturer’s recommended settings for interoperating the host board EDC PHY with a linear receiver SFP+ module. The optical transceivers are compliant per the RoHS Directive 2011/65/EU. See Finisar Application Note AN-2038 for more details.

Product Specifications

I.General Specifications

Parameter	Symbol	Min	Typ.	Max	Unit	Ref.
Bit Rate	BR		10.3125		Gb/s	1
Bit Error Ratio	BER			10 ⁻¹²		2

Maximum Supported Distances

Fiber Type	1310nm OFL Bandwidth	Lmax				
62.5µm	“FDDI” 160MHz-km	Lmax		220	m	3
	OM1 200MHz-km			220		
	400 MHz-km			100		
50µm	OM2 500 MHz-km	Lmax		220	m	3
	OM3 2000 MHz-km			220		

Notes:

1. 10GBASE-LRM
2. Tested with a 2 31 – 1 PRBS
3. Operating range as defined by IEEE standards. Longer reach possible depending upon link implementation.

II. Absolute Maximum Ratings

Parameter	Symbol	Min	Typ.	Max	Unit	Ref.
Maximum Supply Voltage	V _{CC}	-0.5		4.0	V	
Storage Temperature	T _S	-40		85	° C	
Relative Humidity	RH	0		85	%	1

Notes:

1. Non-condensing.

III. Electrical Characteristics (TOP= 0 to 70 ° C, VCC = 3.14 to 3.46 Volts)

Parameter	Symbol	Min	Typ.	Max	Unit	Ref.
Supply Voltage	V _{CC}	3.14		3.46	V	
Supply Current	I _{CC}		200	300	mA	
Power Dissipation	P			1.0	W	

Transmitter

Input differential impedance	R _{in}		100		Ω	1
Differential data input swing	V _{in,pp}	90		350	mV	2
Transmit Disable Voltage	V _D	2		V _{CC}	V	3
Transmit Enable Voltage	V _{EN}	V _{EE}		V _{EE} + 0.8	V	

Receiver

Termination Mismatch at 1 MHz	ΔZ _M			5	%	
Single Ended Output Voltage Tolerance		-0.3		4.0	V	
Output AC Common Mode Voltage				7.5	mV RMS	
Output Rise and Fall time (20% to 80%)	T _r , T _f	30			Ps	4

Receiver

Relative Noise LRM Links with crosstalk	RN	per SFF-8431				5
Difference Waveform Distortion Penalty	dWDP	per SFF-8431			dBo	5,6
Differential Voltage Modulation Amplitude	VMA	180		600	mV	
LOS Fault	$V_{\text{LOS fault}}$	2		$V_{\text{CC HOST}}$	V	7
LOS Normal	$V_{\text{LOS norm}}$	Vee		Vee+0.8	V	7
Power Supply Noise Tolerance	$V_{\text{CC T}}/V_{\text{CC R}}$	per SFF-8431			mVpp	8

Notes:

1. Connected directly to TX data input pins. AC coupling from pins into laser driver IC.
2. Per SFF-8431 Rev 4.1
3. Into 100 ohms differential termination.
4. Measured with Module Compliance Test Board and OMA test pattern.
5. Values shown in Table 20, SFF-8431. dWDP and RN is calculated by the following equation:

$$RN \leq \min[(m1 \times dWDP + b1), (m2 \times dWDP + b2), RN_{max}]$$
6. Defined with reference receiver with 14 T/2 spaced FFE taps and 5 T spaced DFE taps.
7. LOS is an open collector output. Should be pulled up with 4.7k – 10kΩ on the host board. Normal operation is logic 0; loss of signal is logic 1. Maximum pull-up voltage is 5.5V.
8. As described in Section 2.8.1, SFF-8431 Rev 4.1.

IV. Optical Characteristics (TOP = 0 to 70 °C, VCC = 3.14 to 3.46 V)

Parameter	Symbol	Min	Typ.	Max	Unit	Ref.
Transmitter (Tx)						
Optical Modulation Amplitude (OMA)	P_{OMA}	-4.5		+1.5	dBm	
Average Launch Power	P_{AVE}	-6.5		0.5	dBm	1
Peak Launch Power	P_{MAX}			3	dBm	
Optical Wavelength	λ	1260		1355	nm	
RMS Spectral Width	λ_{rms} @1260nm			2.4		
	λ_{rms} @ 1260nm- 1300nm			See Figure as below	nm	2
	λ_{rms} @ 1300nm- 1355nm			4		
Optical Extinction Ratio	ER	3.5			dB	
Optical Eye Mask Margin		0			%	3
Transmitter Waveform Dispersion Penalty	TWDP			4.7	dB	4

Average Launch power of OFF transmitter	P_{OFF}			-30	dBm	
Uncorrelated Jitter [rms]	T_{Xj}			0.033	UI	
Relative Intensity Noise	RIN_{12OMA}			-128	dB/Hz	
Encircled Flux	<5 μ m <11 μ m	30 81			%	
Transmitter Reflectance				-12	dB	
Optical Return Loss Tolerance		20			dB	
Receiver (Rx)						
Receiver Overload	POMA	+1.5			dBm	5
	Precursor			-6.5		
Comprehensive Stressed Receiver Sensitivity (OMA) @ 10.3125Gb/s	Symmetrical			-6.0	dBm	6
	Postcursor			-6.5		
Wavelength Range	λ_C	1260		1355	N_m	
Receiver Reflectance	R_{rx}			-12	dB	
LOS De-Assert	LOS_D			-11	dBm	
LOS Assert	LOS_A	-30			dBm	
LOS Hysteresis		0.5			dB	

Notes:

1. Average power figures are informative only, per IEEE802.3aq
2. Maximum RMS spectral width as specified by Figure as below
3. Optical Eye Mask requires the host board to be SFF-8431 compliant. Optical eye mask per IEEE802.3aq.
4. TWDP figure requires the host board to be SFF-8431 compliant. TWDP is calculated
5. using the Matlab code provided in clause 68.6.6.2 of IEEE802.3aq Receiver overload specified in OMA and under the worst comprehensive stressed condition.
6. Conditions of stressed receiver tests per IEEE802.3aq. CSRS testing requires the host board to be SFF-8431 compliant.

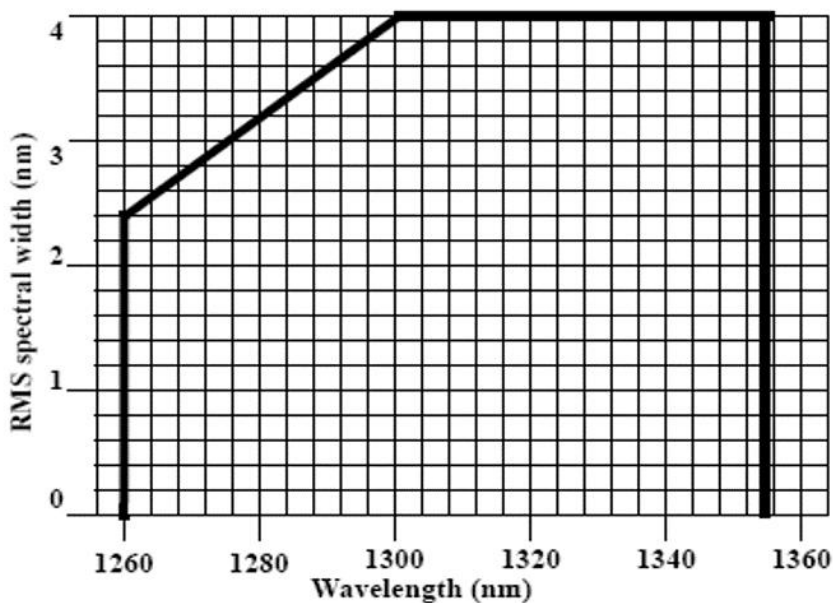

Transmitter Maximum RMS Spectral Width

V.Digital Diagnostic Specifications

The transceiver can be used in host systems that require either internally or externally calibrated digital diagnostics.

Parameter	Symbol	Min	Typ.	Max	Units	Ref.
Accuracy						
Internally measured transceiver temperature	DD_{Temp}			3	°C	
Internally measured transceiver supply voltage	$DD_{Voltage}$			100	mV	
Measured TX bias current	DD_{Bias}			10	%	1
Measured TX output power	$DD_{Tx-Power}$			2	dB	
Measured RX received average optical power	$DD_{Rx-Power}$			2	dB	

Parameter	Symbol	Min	Typ.	Max	Units	Ref.
-----------	--------	-----	------	-----	-------	------

Dynamic Range for Rated Accuracy

Internally measured transceiver temperature	DD _{Temp}	-5		75	°C	
Internally measured transceiver supply voltage	DD _{Voltage}	3.1		3.5	V	
Measured TX bias current	DD _{Bias}	0		75	mA	
Measured TX output power	DD _{Tx-Power}	-6.5		0.5	dBm	
Measured RX received average optical power	DD _{Rx-Power}	-20		-10	dBm	

Max Reporting Range

Internally measured transceiver temperature	DD _{Temp}	-40		125	°C	
Internally measured transceiver supply voltage	DD _{Voltage}	2.8		4.0	V	
Measured TX bias current	DD _{Bias}	0		75	mA	
Measured TX output power	DD _{Tx-Power}	-10		3	dBm	
Measured RX received average optical power	DD _{Rx-Powe}	-22		0	dBm	

Note:

1. Accuracy of Measured Tx Bias Current is 10% of the actual Bias Current from the laser driver to the laser.

VI. Pin Description

Pin	Symbol	Name/Description	Ref.
1	V _{EET}	Transmitter Ground	1
2	T _{FAULT}	Transmitter Fault	
3	T _{DIS}	Transmitter Disable. Laser output disabled on high or open.	2
4	SDA	2-wire Serial Interface Data Line	3
5	SCL	2-wire Serial Interface Clock Line	3
6	MOD_ABS	Module Absent. Grounded within the module	3
7	RS0	No connection required	
8	RX_LOS	Loss of Signal indication. Logic 0 indicates normal operation.	4
9	RS1	No connection required	
10	V _{EER}	Receiver Ground	1
11	V _{EER}	Receiver Ground	1
12	RD-	Receiver Inverted DATA out. AC Coupled.	
13	RD+	Receiver Non-inverted DATA out. AC Coupled.	
14	V _{EER}	Receiver Ground	1
15	V _{CCR}	Receiver Power Supply	
16	V _{CCT}	Transmitter Power Supply	
17	V _{EET}	Transmitter Ground	1
18	TD+	Transmitter Non-Inverted DATA in. AC Coupled.	
19	TD-	Transmitter Inverted DATA in. AC Coupled.	
20	V _{EET}	Transmitter Ground(Common with Receiver Ground)	1

Notes:

1. Circuit ground is internally isolated from chassis ground.
2. Laser output disabled on T DIS >2.0V or open, enabled on T DIS <0.8V.
3. Should be pulled up with 4.7kΩ – 10kΩ on host board to a voltage between 2.0V and 3.6V. MOD_ABS pulls line low to indicate module is plugged in.
4. RX_LOS is open collector output. Should be pulled up with 4.7kΩ – 10kΩ on host board to a voltage between 2.0V and 3.6V. Logic 0 indicates normal operation; logic 1 indicates loss of signal.

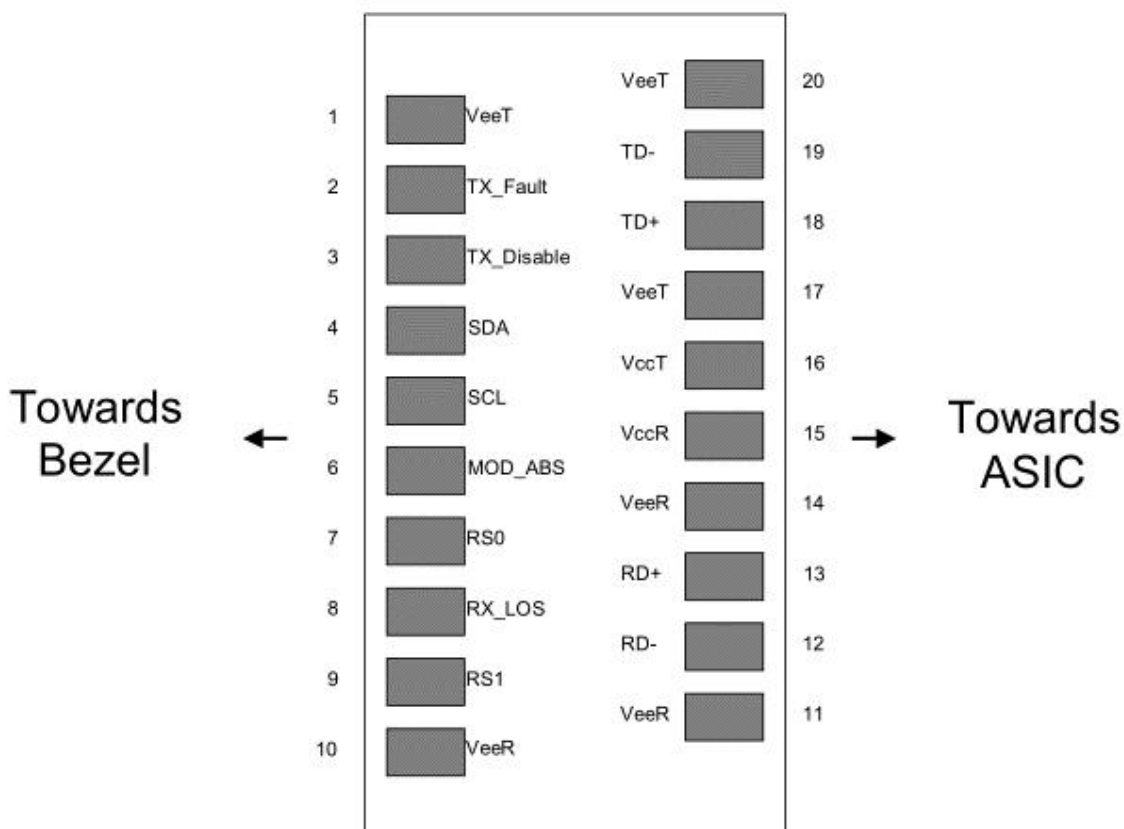

VII. Mechanical Specifications

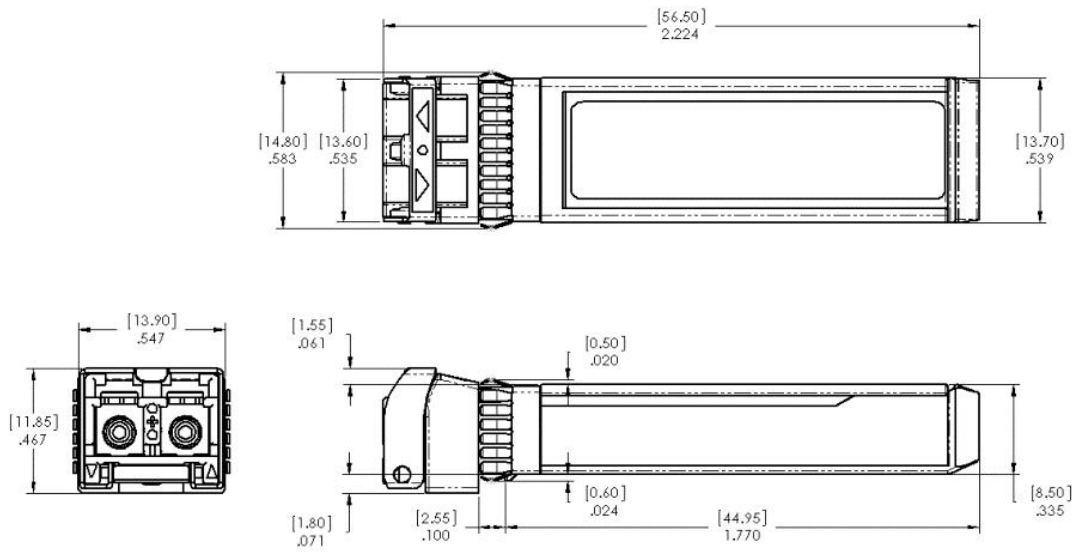

VIII. Host Board SFP+ Connector Recommendations

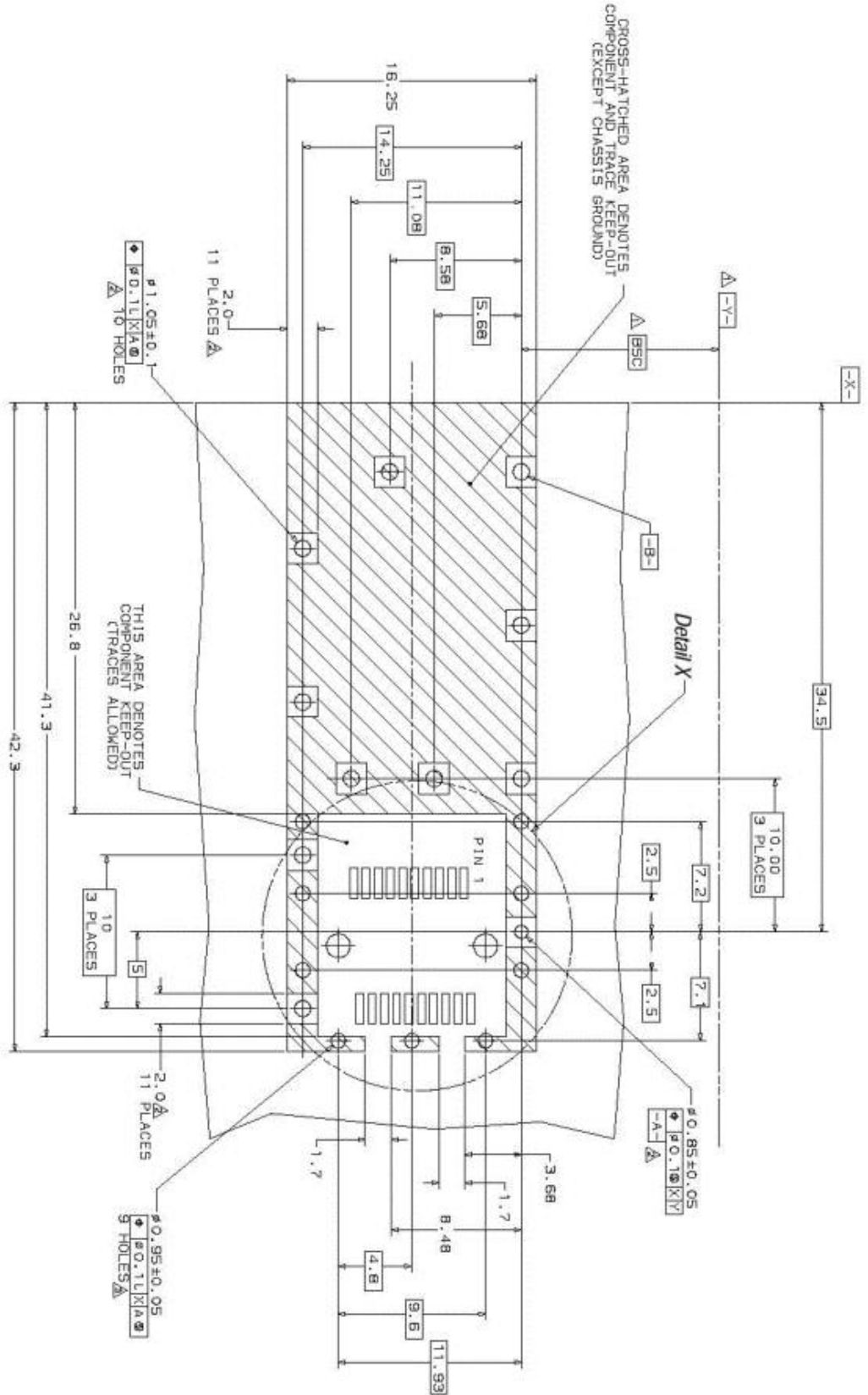

Δ Datum and Basic Dimension Established by Customer

ϕ Pads and Vias are Chassis Ground, 11 Places

Δ Through Holes are Unplated

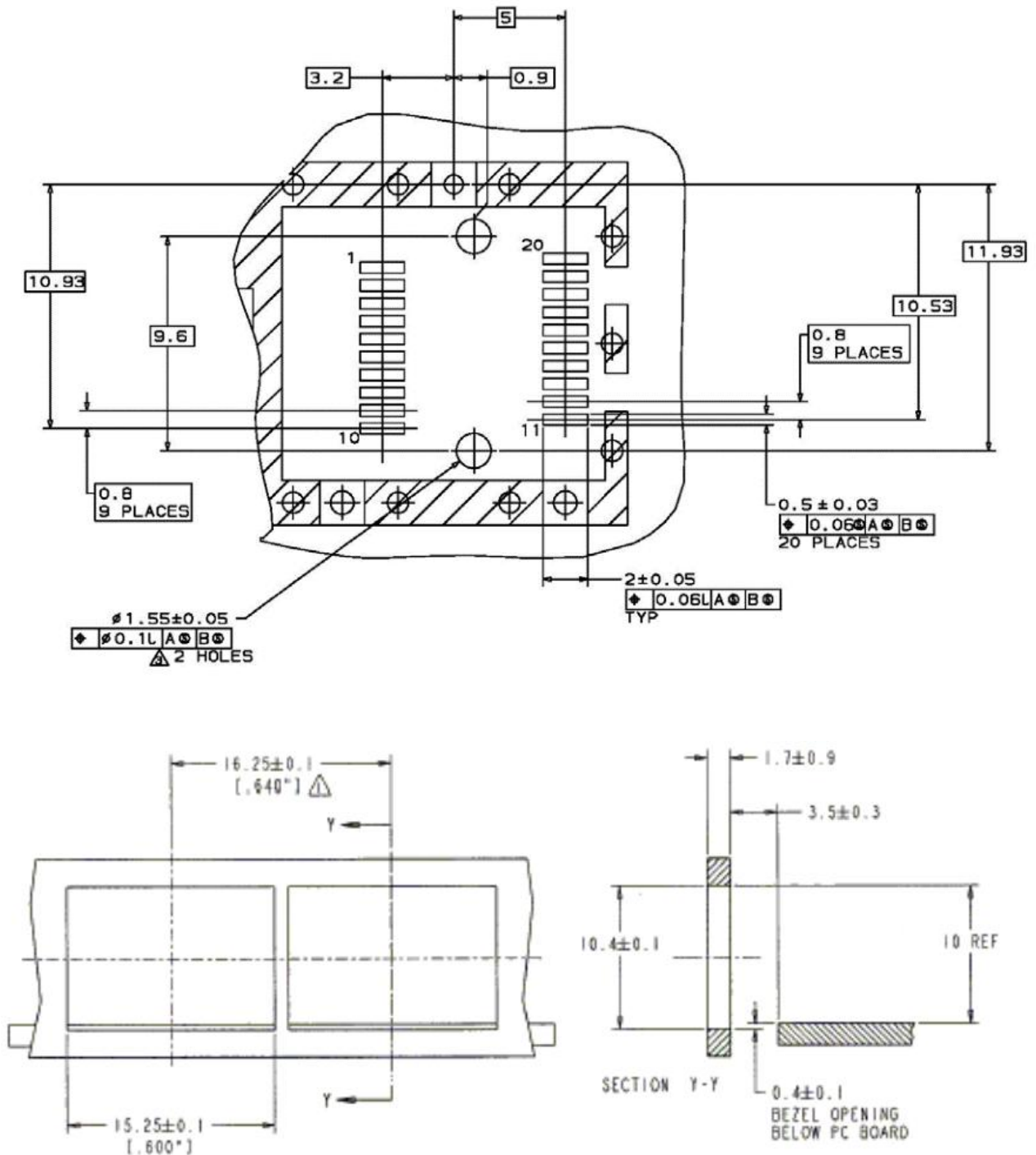

- NOTES:
- △ MINIMUM PITCH ILLUSTRATED, ENGLISH DIMENSIONS ARE FOR REFERENCE ONLY
 - 2. NOT RECOMMENDED FOR PCI EXPANSION CARD APPLICATIONS

Test Center

FS.COM transceivers are tested to ensure connectivity and compatibility in our test center before shipped out. FS.COM test center is supported by a variety of mainstream original brand switches and groups of professional staff, helping our customers make the most efficient use of our products in their systems, network designs and deployments.

The original switches could be found nowhere but at FS.COM test center, eg: Juniper MX960 & EX 4300 series, Cisco Nexus 9396PX & Cisco ASR 9000 Series, HP 5900 Series & HP 5406R ZL2 V3(J9996A), Arista 7050S-64, Brocade ICX7750-26Q & ICX6610-48, Avaya VSP 7000 MDA 2, etc.



Cisco ASR 9000 Series(A9K-MPA-1X40GE)



ARISTA 7050S-64(DCS-7050S-64)



Juniper MX960



Brocade ICX 7750-26Q



Extreme Networks X670V VIM-40G4X



Mellanox M3601Q



Dell N4032F



HP 5406R ZL2 V3(J9996A)



AVAYA 7024XLS(7002QQ-MDA)

Test Assured Program

FS.COM truly understands the value of compatibility and interoperability to each optics. Every module FS.COM provides must run through programming and an extensive series of platform diagnostic tests to prove its performance and compatibility. In our test center, we care of every detail from staff to facilities—professionally trained staff, advanced test facilities and comprehensive original-brand switches, to ensure our customers to receive the optics with superior quality.

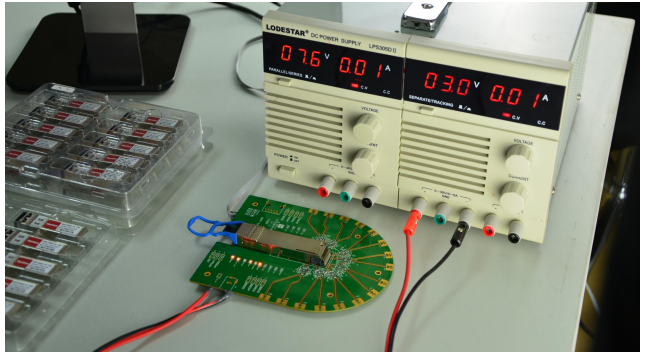

Our smart data system allows effective product management and quality control according to the unique serial number, properly tracking the order, shipment and every part.

Our in-house coding facility programs all of our parts to standard OEM specs for compatibility on all major vendors and systems such as Cisco, Juniper, Brocade, HP, Dell, Arista and so on.



With a comprehensive line of original-brand switches, we can recreate an environment and test each optics in practical application to ensure quality and distance.

The last test assured step to ensure our products to be shipped with perfect package.

Order Information

Part Number	Description
SFP-10GSR-85	10GBASE-SR SFP+ 850nm 300m DOM Transceiver
SFP-10GLRM-31	10GBASE-LRM SFP+ 1310nm 220m DOM Transceiver
SFP-10GLR-31	10GBASE-LR SFP+ 1310nm 10km DOM Transceiver
SFP-10GER-55	10GBASE-ER SFP+ 1550nm 40km DOM Transceiver
SFP-10GZR-55	10GBASE-ZR SFP+ 1550nm 80km DOM Transceiver
SFP-10GZRC-55	10GBASE-ZR SFP+ 1550nm 100km DOM Transceiver
SFP-10GSR-85	Dual-Rate 1000BASE-SX and 10GBASE-SR SFP+ 850nm 300m DOM Transceiver
SFP-10GLR-31	Dual-Rate 1000BASE-LX and 10GBASE-LR SFP+ 1310nm 10km DOM Transceiver

Note:

1. 10G SFP+ transceiver module is individually tested on corresponding equipment such as Cisco, Arista, Juniper, Dell, Brocade and other brands, and passes the monitoring of FS.COM intelligent quality control system.



 <https://www.fs.com>



The information in this document is subject to change without notice. FS has made all efforts to ensure the accuracy of the information, but all information in this document does not constitute any kind of warranty.