

10GBASE-ER SFP+ 1310nm 40km Industrial DOM Transceiver

SFP-10GER-31-I



Application

- 10GBASE-LR/LW 10G
- Ethernet
- 10GFC
- 8GFC

Features

- Hot-pluggable SFP+ footprint
- Link lengths at 10G 30Km with DFB 1310nm
- Supports 6.1 Gb/s to 10.52 Gb/s
- Un-cooled 1310nm DFB laser
- Receiver limiting electrical interface
- Power dissipation < 1.3W
- -40°C to 85°C temperature range
- RoHS-6 compliant (lead-free)
- Single 3.3V power supply
- Duplex LC connector
- Built-in digital diagnostic functions

Description

The 10Gigabit 1310nm DFB Transceiver is designed to transmit and receive serial optical data links up from 6.1 Gb/s to 10.52 Gb/s data rate over 30km singlemode fiber. The Transceiver is compliant with SFF-8432, 10GFC, FC-PI-4, IEEE802.3ae and applicable portions of SFF-8431. Digital diagnostics functions are available via a 2-wire serial interface, as specified in SFF-8472.

Product Specifications

I. Absolute Maximum Ratings

Parameter	Symbol	Min	Typ.	Max	Unit	Ref.
Maximum Supply Voltage	V _{cc}	-0.3		4.0	V	
Storage Temperature	T _s	-40		85	°C	
Relative Humidity	RH	0		95	%	

II.Recommended Operating Conditions

Parameter	Symbol	Min	Typ.	Max	Unit	Ref.
Operating Case Temperature Range	Tc	-40		85	°C	
Power Supply Voltage	Vcc	3.14	3.3	3.46	V	
Bit Rate	BR	6.1		10.52	Gb/s	
Bit Error Ratio	BER			10 ⁻¹²		
Max Supported Link Length	L			30	km	

III. Principle Diagram

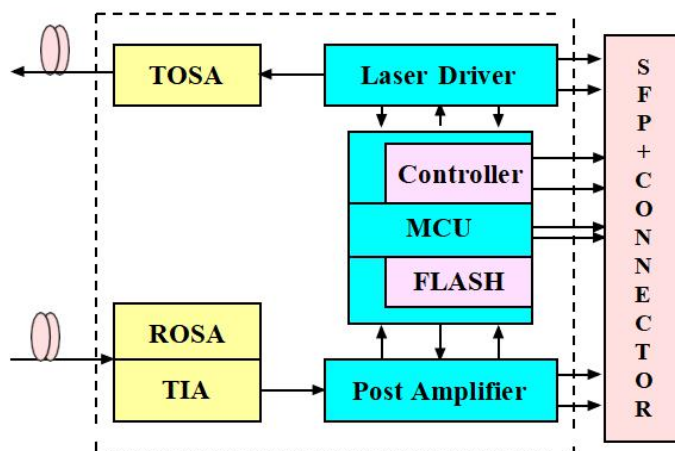

IV. Electrical Characteristics (TOP = -40 to 85 °C, VCC = 3.14 to 3.46 V)

Parameter	Symbol	Min	Typ.	Max	Unit	Ref.
Supply Voltage	V _{CC}	3.14	3.30	3.46	V	
Supply Current	I _{CC}			390	mA	
Transmitter						
Input differential impedance	R _{IN}	80	100	120	Ω	1
Differential data input swing	V _{IN}	180		700	mVp-p	
Transmit Disable Voltage	V _{DIS}	2		V _{CCHOST}	V	
Transmit Enable Voltage	V _{EN}	V _{EE}		V _{EE} +0.8	V	
Transmit Fault Assert Voltage	V _{FA}	2.2		V _{CCHOST}	V	
Transmit Fault De-Assert Voltage	V _{FDA}	V _{EE}		V _{EE} +0.4	V	
Receiver						
Differential data output swing	V _{OD}	450	600	850	mVp-p	
Output rise time and fall time	T _r , T _f	25			ps	
LOS Fault	V _{LOSFT}	2		V _{CCHOS}	V	
LOS Normal	V _{LOSNR}	V _{EE}		V _{EE} +0.8	V	

Notes:

1. NOTE 1: Differential between TD+ / TD-

V. Optical Characteristics (TOP = -40 to 85 °C, VCC = 3.14 to 3.46 V)

Parameter	Symbol	Min	Typ.	Max	Unit	Note
Transmitter (Tx)						
Nominal Wavelength	λ	1260	1310	1355	nm	
Side Mode Suppression Ratio	SMSR	30			dB	
Spectral width	$\Delta\lambda$	nm		1		
Optical Output Power	P_{AV}			1 3	dBm	20km 30km
Optical Modulation Amplitude ¹	P_{OMA}	-5 -1			dBm	20km 30km
Extinction Ratio	ER	3.5			dB	
Average launch power of OFF transmitter	P_{OFF}			-35	dBm	
Relative Intensity Noise	R_{IN}			-128	dB/Hz	
Optical Return Loss Tolerance	ORLT	-15			dB	
Receiver (Rx)						
Center Wavelength	λ	1260		1610	nm	
Average Receiver Power	P_{AVG}			+1	dBm	
Receiver Sensitivity ² (OMA)	R_{SENSE1}			-15	dBm	
Receiver Reflectance	R_{REFL}			-15	dB	

Assert LOS	LOS _A	-30				dBm	
De-Assert LOS	LOS _D				-17	dBm	
LOS Hysteresis			0.5			dB	

Notes:

- OMA = OMAmin – TDP, sum of all penalties incorporated, incl. aging and interoperability margin
- achieved with worst case jitter stress at δt , and maximum reflection at γt , Jitter total @ δt , BER < 10⁻¹²
= 0.28UI (informative)

VI. Digital Diagnostic Specifications

Parameter	Symbol	Units	Min	Max	Accuracy	Ref.
Accuracy						
Transceiver temperature	ΔDD_{Temp}	°C	-40	85	±5°C	1
Transceiver supply voltage	$\Delta DD_{Voltage}$	V	3.14	3.46	±3%	
Transmitter bias current	ΔDD_{Bias}	mA	0	20	±10%	2
Transmitter output power	$\Delta DD_{Tx-Power}$	dBm	-10	+2	±2dB	
Receiver average optical input power	$\Delta DD_{Rx-Power}$	dBm	-22	+2	±2dB	

Notes:

- Internally measured
- The accuracy of the Tx bias current is 10% of the actual current from the laser driver to the laser

VII. Pin Description

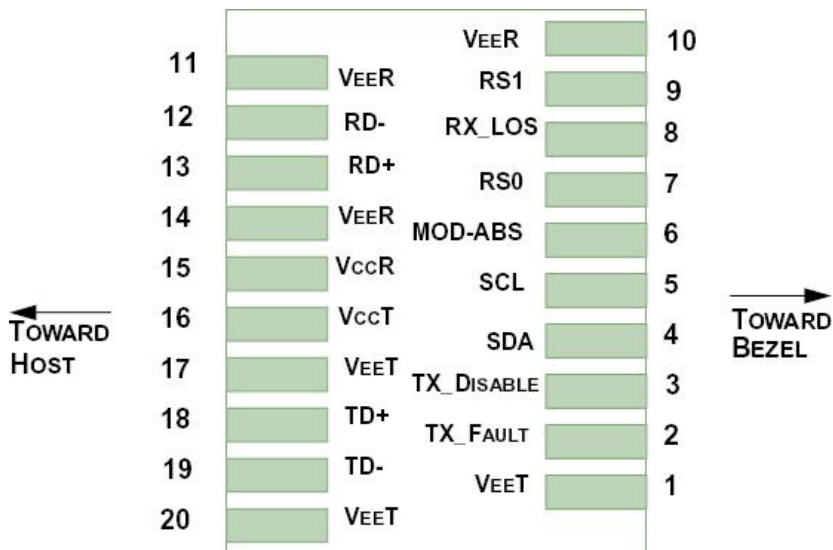

Figure 1 – Diagram of Host Board Connector Block Pin Numbers and Names.

Pin	Symbol	Name/Description	Notes
1	VEET	Transmitter Ground	1
2	TFault	Transmitter Fault	2
3	TDIS	Transmitter Disable. Laser output disabled on high or open.	3
4	SDA	2-wire Serial Interface Data Line	2
5	SCL	2-wire Serial Interface Clock Line	2
6	MOD_ABS	Module Absent. Grounded within the module	2
7	RS0	Rate Select 0.	4
8	RX_LOS	Loss of Signal indication. Logic 0 indicates normal operation.	5
9	RS1	Rate Select 1.	4

10	VEER	Receiver Ground	1
11	VEER	Receiver Ground	1
12	RD-	Receiver Inverted DATA out. AC Coupled.	
13	RD+	Receiver Non-inverted DATA out. AC Coupled.	
14	VEER	Receiver Ground	1
15	VCCR	Receiver Power Supply	
16	VCCT	Transmitter Power Supply	
17	VEET	Transmitter Ground	1
18	TD+	Transmitter Non-Inverted DATA in. AC Coupled.	
19	TD-	Transmitter Inverted DATA in. AC Coupled.	
20	VEET	Transmitter Ground	1

Notes:

1. Circuit ground is internally isolated from chassis ground.
2. TFAULT is an open collector/drain output, which should be pulled up with a 4.7k -10k Ohms resistor on the host board if intended for use. Pull up voltage should be transmitter fault caused by either the TX bias current or the TX output powerexceeding the preset alarm thresholds. A low output indicates normal operation. In the low state, the output is pulled to <0.8V.
3. Laser output disabled on TDIS >2.0V or open, enabled on TDIS <0.8V.
4. Internally pulled down per SFF-8431 Rev 2.0. See Sec. X for the logic table to use for the internal CDRs locking modes.
5. LOS is open collector output. Should be pulled up with 4.7kΩ -10kΩ on host board to a voltage between 2.0V and 3.6V. Logic 0 indicates normal operation; logic 1 indicates loss of signal.

VIII. Typical Application Circuit

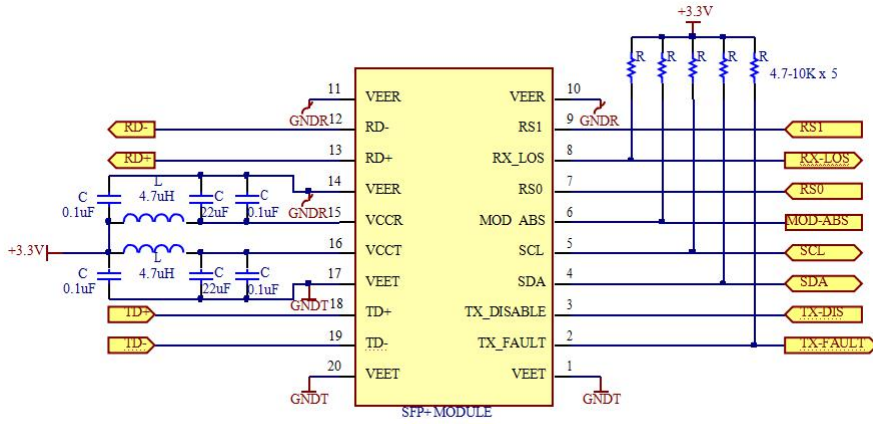

IX. Mechanical Specifications

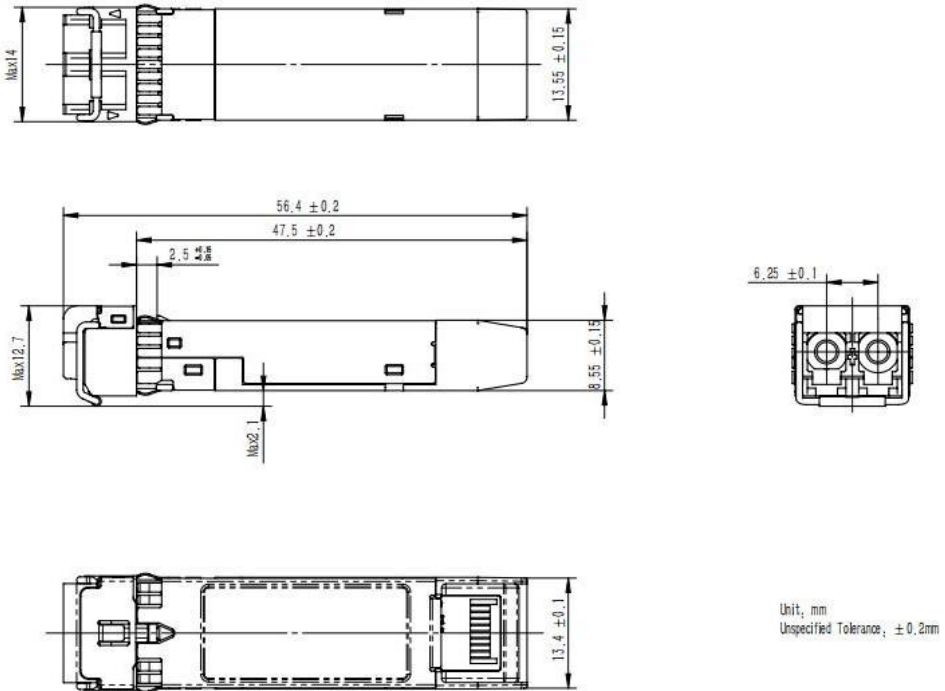

X. Regulatory Compliance

Feature	Test Method	Performance
Electrostatic Discharge (ESD) to the Electrical Pins	MIL-STD-883C Method 3015.7	Class 1 (> 1500 Volts)
Electrostatic Discharge (ESD) Immunity	Variation of IEC 61000-4-2	LV 4(Air discharge :15KV;Contact discharge:8 KV) Performance criterion:B
Electromagnetic Interference (EMI)	CISPR22 ITE Class B EN55022 Class B FCC Class B	Compliant with standards
Immunity	IEC61000-4-3 Class 2 EN55024	Typically show no measurable effect from a 3V/m field swept from 80 to 1000MHz applied to the transceiver without a chassis enclosure.

Test Center

FS.COM transceivers are tested to ensure connectivity and compatibility in our test center before shipped out. FS.COM test center is supported by a variety of mainstream original brand switches and groups of professional staff, helping our customers make the most efficient use of our products in their systems, network designs and deployments.

The original switches could be found nowhere but at FS.COM test center, eg: Juniper MX960 & EX 4300 series, Cisco Nexus 9396PX & Cisco ASR 9000 Series, HP 5900 Series & HP 5406R ZL2 V3(J9996A), Arista 7050S-64, Brocade ICX7750-26Q & ICX6610-48, Avaya VSP 7000 MDA 2, etc.



Cisco ASR 9000 Series(A9K-MPA-140GE)



ARISTA 7050S-64(DCS-7050S-64)



Juniper MX960



Brocade ICX 7750-26Q



Extreme Networks X670V VIM-40G4X



Mellanox M3601Q



Dell N4032F



HP 5406R ZL2 V3(J9996A)



AVAYA 7024XLS(7002QQ-MDA)

Test Assured Program

FS.COM truly understands the value of compatibility and interoperability to each optics. Every module FS.COM provides must run through programming and an extensive series of platform diagnostic tests to prove its performance and compatibility. In our test center, we care of every detail from staff to facilities—professionally trained staff, advanced test facilities and comprehensive original-brand switches, to ensure our customers to receive the optics with superior quality.



Our smart data system allows effective product management and quality control according to the unique serial number, properly tracing the order, shipment and every part.

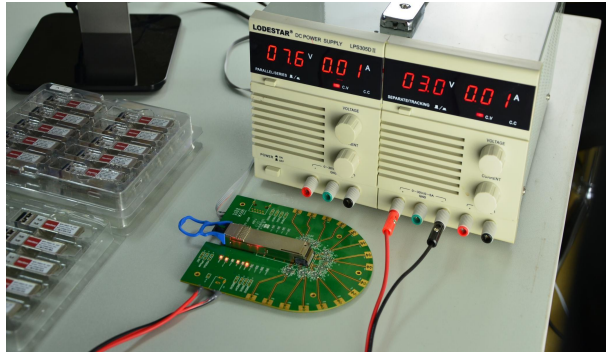

Our in-house coding facility programs all of our parts to standard OEM specs for compatibility on all major vendors and systems such as Cisco, Juniper, Brocade, HP, Dell, Arista and so on.



With a comprehensive line of original-brand switches, we can recreate an environment and test each optics in practical application to ensure quality and distance.



The last test assured step to ensure our products to be shipped with perfect package.

Order Information

Part Number	Description
SFP-10GSR-85	10GBASE-SR SFP+ 850nm 300m DOM Transceiver
SFP-10GLRM-31	10GBASE-LRM SFP+ 1310nm 220m DOM Transceiver
SFP-10GLR-31	10GBASE-LR SFP+ 1310nm 10km DOM Transceiver
SFP-10GER-55	10GBASE-ER SFP+ 1550nm 40km DOM Transceiver
SFP-10GZR-55	10GBASE-ZR SFP+ 1550nm 80km DOM Transceiver
SFP-10GZRC-55	10GBASE-ZR SFP+ 1550nm 100km DOM Transceiver
SFP-10GSR-85	Dual-Rate 1000BASE-SX and 10GBASE-SR SFP+ 850nm 300m DOM Transceiver
SFP-10GLR-31	Dual-Rate 1000BASE-LX and 10GBASE-LR SFP+ 1310nm 10km DOM Transceiver
SFP-10G-T	10GBASE-T SFP+ Copper RJ-45 30m Transceiver
SFP-10GSR-85-I	10GBASE-SR SFP+ 850nm 300m Industrial DOM Transceiver
SFP-10GLR-31-I	10GBASE-LR SFP+ 1310nm 10km Industrial DOM Transceiver
SFP-10GER-31-I	10GBASE-ER SFP+ 1550nm 40km Industrial DOM Transceiver
SFP-10G-T-I	10GBASE-T SFP+ Copper RJ-45 30m Industrial Transceiver

Notes:

1.10G SFP+ transceiver module is individually tested on corresponding equipment such as Cisco, Arista, Juniper, Dell, Brocade and other brands, and passes the monitoring of FS.COM intelligent quality control system.



 <https://www.fs.com>



The information in this document is subject to change without notice. FS has made all efforts to ensure the accuracy of the information, but all information in this document does not constitute any kind of warranty.