

100G QSFP28 to 25G SFP28 Adapter Converter Module

CVR-QSFP28-SFP28

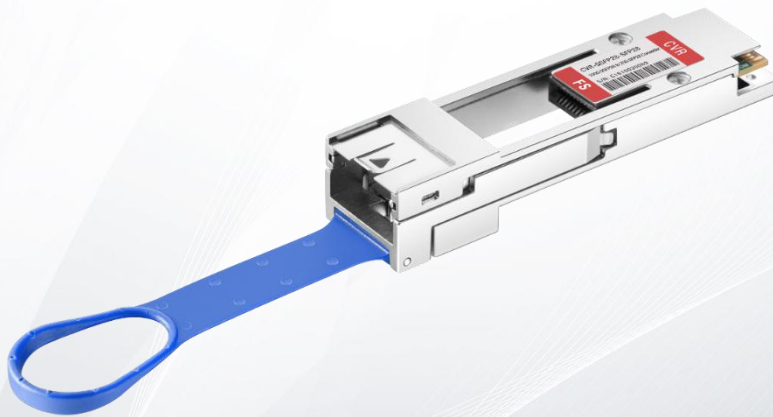

Application

- Low EMI radiation Switches, servers and routers
- Telecommunication and wireless infrastructure
- Test and measurement equipment
- Networked storage systems
- Data Center networks
- Storage area networks
- IEEE-802.3bj
- 25G Ethernet

Features

- Trouble-free installation and network bring-up
- Low insertion loss
- Low crosstalk
- Secure latching mechanism
- Operating case temperature: -20 to 85°C
- 100 ohm differential impedance system
- Compliant to industry standards: SFF-8665 IEEE802.3bj/ SFF-8432 IEEE-802.3
- All-metal housing for superior EMI performance
- RoHS compliant
- Precision process control for minimization of pair-to-pair skew
- 1 independent duplex channels operating at 25Gbps, also support for 5Gbps, 10Gbps data rates

I. Product Descriptions

The QSFP28 to SFP28 Adapter (QSA) Module offers 25 Gigabit Ethernet connectivity for Quad Small Form-Factor Pluggable (QSFP28)-only platforms. It allows smooth and cost-effective migration to 100 Gigabit Ethernet by providing an option to use lower-speed Enhanced Small Form-Factor Pluggable (SFP28) modules in empty QSFP28 ports or when the other end of the network is running at lower speeds.

The QSA Module converts a QSFP28 port into an SFP28 port. With this adapter, customers have the flexibility to use any SFP28 module or cable to connect to a lower-speed port on the other end of the network. This flexibility allows a cost-effective transition to 100 Gigabit Ethernet by maximizing the use of high-density 100 Gigabit Ethernet QSFP28 platforms. This adapter supports all SFP28 optics and cable reaches. Compatible Switch Models and SFP28 Modules. A list of SFP28 transceiver modules that can be plugged into the QSA module is provided in Table .

SFP or SFP+ Transceiver Modules

Item	Product Name	Product Description
1	SFP28-SR	25GBASE-SR SFP28 Module for Multimode Fiber
2	SFP28-LR	25G BASE-LR SFP28 Module for Single-Mode Fiber
3	SFP28 Passive Copper Cable	SFP28 Copper Cables (1-m to 5-m lengths)
4	SFP28 Active Optical Cable	SFP28 AOC Optical Cables

II. Recommended Operation Condition

Parameter	Symbol	Min	Max	Unit
Operating Case Temperature	Topc	-20	85	degC
Storage Temperature	Tst	-40	125	degC
Relative Humidity (non-condensation)	RS	-	85	%
Supply Voltage	VCC3	3.15	3.45	V

III. QSFP28 Host Board Connector Pinout

Figure 1: MSA Compliant Connector

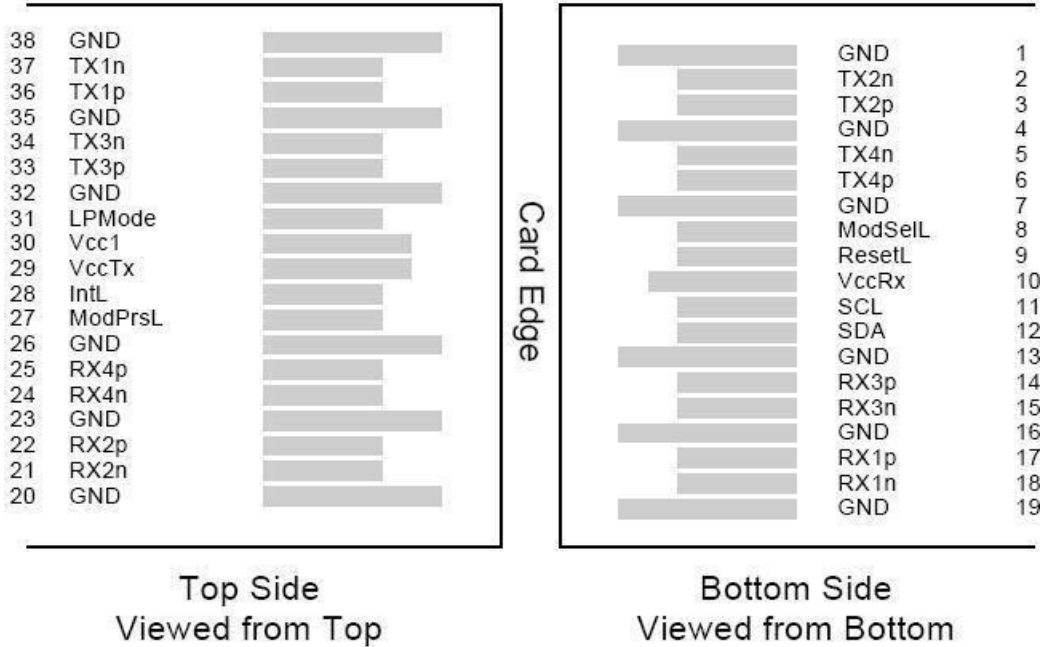

Figure 2: Pin Definitions

Pin	Logic	Symbol	Name/Description	Note
1		GND	Ground	1
2	CML-I	Tx2n	Transmitter Inverted Data Input	
3	CML-I	Tx2p	Transmitter Non-Inverted Data output	
4		GND	Ground	1
5	CML-I	Tx4n	Transmitter Inverted Data Input	
6	CML-I	Tx4p	Transmitter Non-Inverted Data output	
7		GND	Ground	1
8	LVTLL-I	ModSelL	Module Select	
9	LVTLL-I	ResetL	Module Reset	
10		VccRx	+ 3.3V Power Supply Receiver	2
11	LVC MOS-I/O	SCL	2-Wire Serial Interface Clock	
12	LVC MOS-I/O	SDA	2-Wire Serial Interface Data	
13		GND	Ground	1

14	CML-O	Rx3p	Receiver Non-Inverted Data Output	
15	CML-O	Rx3n	Receiver Inverted Data Output	
16		GND	Ground	1
17	CML-O	Rx1p	Receiver Non-Inverted Data Output	
18	CML-O	Rx1n	Receiver Inverted Data Output	
19		GND	Ground	1
20		GND	Ground	1
21	CML-O	Rx2n	Receiver Inverted Data Output	
22	CML-O	Rx2p	Receiver Non-Inverted Data Output	
23		GND	Ground	1
24	CML-O	Rx4n	Receiver Inverted Data Output	1
25	CML-O	Rx4p	Receiver Non-Inverted Data Output	
26		GND	Ground	1
27	LVTTTL-O	ModPrsL	Module Present	
28	LVTTTL-O	IntL	Interrupt	
29		VccTx	+3.3 V Power Supply transmitter	2
30		Vcc1	+3.3 V Power Supply	2
31	LVTTTL-I	LPMODE	Low Power Mode	
32		GND	Ground	1
33	CML-I	Tx3p	Transmitter Non-Inverted Data Input	
34	CML-I	Tx3n	Transmitter Inverted Data Output	
35		GND	Ground	1
36	CML-I	Tx1p	Transmitter Non-Inverted Data Input	
37	CML-I	Tx1n	Transmitter Inverted Data Output	
38		GND	Ground	1

Notes:

1. GND is the symbol for signal and supply (power) common for QSFP modules. All are common within the QSFP module and all module voltages are referenced to this potential otherwise noted. Connect these directly to the host board signal common ground plane
2. cc Rx, Vcc1 and Vcc Tx are the receiver and transmitter power suppliers and shall be applied concurrently. Recommended host board power supply filtering is shown below. Vcc Rx, Vcc1 and Vcc Tx may be internally connected within the QSFP transceiver module in any combination. The connector pins are each rated for a maximum current of 500mA.

IV. SFP28 Host Board Connector Pinout for SFP28

Figure 1: MSA Compliant Connector

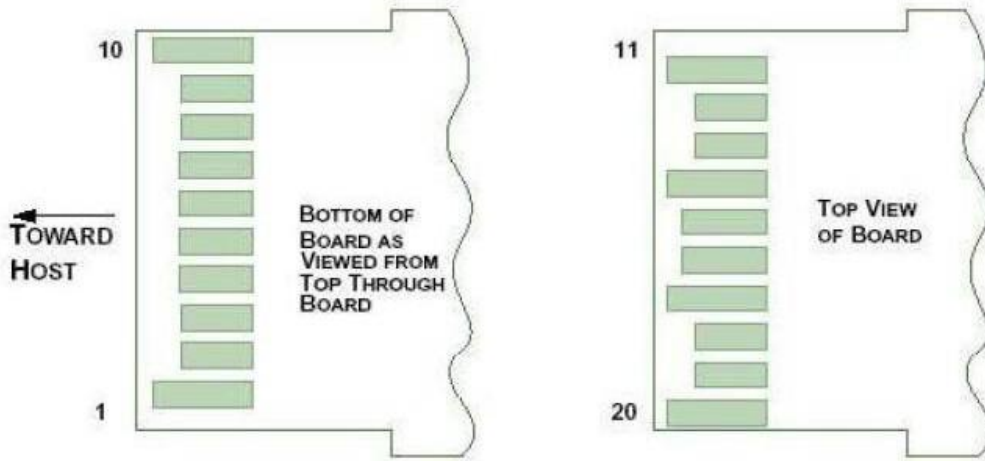

Figure 2: Pin Definitions

Pin	Logic	Symbol	Name/Description	Note
1		VeeT	Module Transmitter Ground	1
2	LVTTTL-O	Tx_Fault	Transmitter Fault	2
3	LVTTTL-I	Tx_Disable	Transmitter Disable	3
4	LVTTTL-I/O	SDA	MOD-DEF2 2-wire serial interface data line	4
5	LVTTTL-I/O	SCL	MOD-DEF1 2-wire serial interface clock line	4
6		Mod_Abs	Module Absent	5
7	LVTTTL-I	RS0	Rate Select Zero	
8	LVTTTL-O	Rx_LOS	Module Receiver Loss of Signal	2
9	LVTTTL-I	RS1	Rate Select One	
10		VeeR	Module Receiver Ground	1
11		VeeR	Module Receiver Ground	1
12	CML-O	RD-	Receiver Inverted Data Output	

13	CML-O	RD+	Receiver Non-Inverted Data Output	
14		VeeR	Module Receiver Ground	1
15		VccR	Module Receiver 3.3V Supply	
16		VccT	Module Transmitter 3.3V Supply	
17		VeeT	Module Transmitter Ground	1
18	CML-I	TD+	Transmitter Non-Inverted Data Input	
19	CML-I	TD-	Transmitter Inverted Data Input	
20		VeeT	Module Transmitter Ground	1

Notes:

- 1.The module signal grounds, VeeR and VeeT, shall be isolated from the module case.
- 2.This is an open collector/drain output and shall be pulled up with 4.7-10k to Vcc_Host on the host board. Pull ups can be connected to multiple power supplies, however the host board design shall ensure that no module has voltage exceeding module VccT/R + 0.5 V.
- 3.This is an open collector/drain input and shall be pulled up with 4.7-10k to VccT in the module.
- 4.See 2-wire electrical specifications .
- 5.This shall be pulled up with 4.7-10k to Vcc_Host on the host board.

V. Mechanical Dimensions

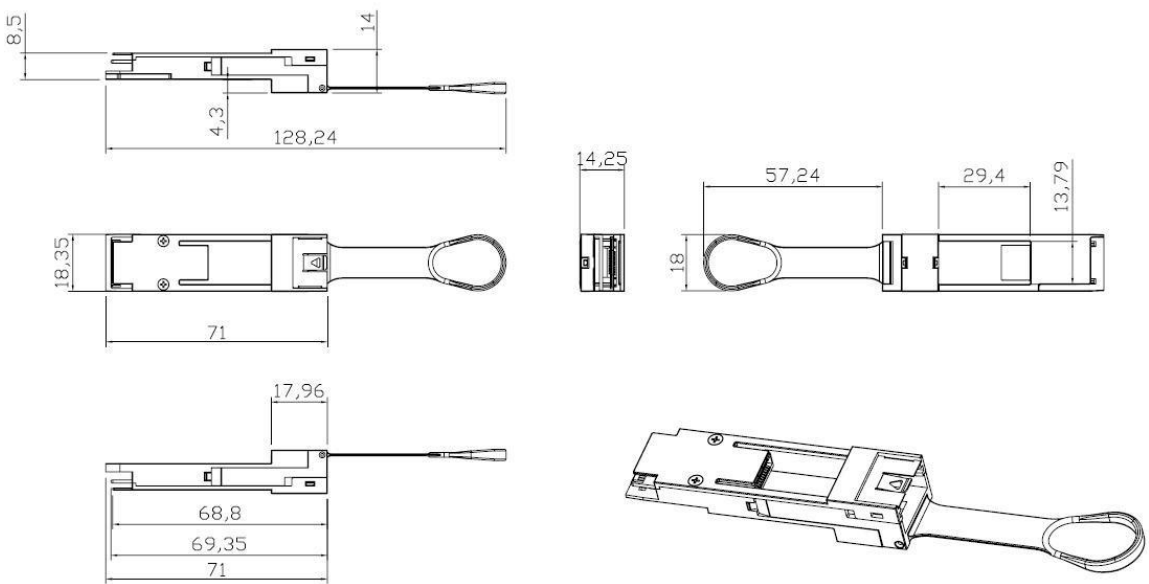

Test Center

FS.COM transceivers are tested to ensure connectivity and compatibility in our test center before shipped out. FS.COM test center is supported by a variety of mainstream original brand switches and groups of professional staff, helping our customers make the most efficient use of our products in their systems, network designs and deployments.

The original switches could be found nowhere but at FS.COM test center, eg: Juniper MX960 & EX 4300 series, Cisco Nexus 9396PX & Cisco ASR 9000 Series, HP 5900 Series & HP 5406R ZL2 V3(J9996A), Arista 7050S-64, Brocade ICX7750-26Q & ICX6610-48, Avaya VSP 7000 MDA 2, etc.



Cisco ASR 9000 Series(A9K-MPA-1X40GE)



ARISTA 7050S-64(DCS-7050S-64)



Juniper MX960



Brocade ICX 7750-26Q



Extreme Networks X670V VIM-40G4X



Mellanox M3601Q



Dell N4032F



HP 5406R ZL2 V3(J9996A)



AVAYA 7024XLS(7002QQ-MDA)

Test Assured Program

FS.COM truly understands the value of compatibility and interoperability to each optics. Every module FS.COM provides must run through programming and an extensive series of platform diagnostic tests to prove its performance and compatibility. In our test center, we care of every detail from staff to facilities—professionally trained staff, advanced test facilities and comprehensive original-brand switches, to ensure our customers to receive the optics with superior quality.



Our smart data system allows effective product management and quality control according to the unique serial number, properly tracing the order, shipment and every part.

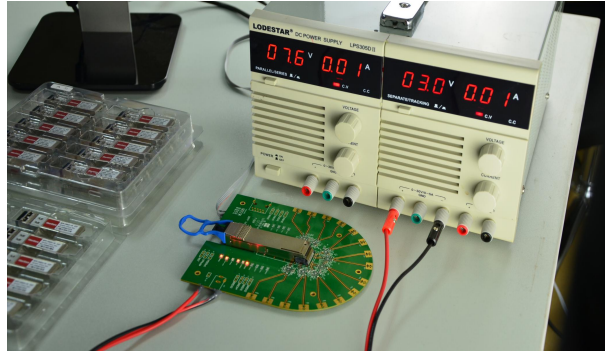

Our in-house coding facility programs all of our parts to standard OEM specs for compatibility on all major vendors and systems such as Cisco, Juniper, Brocade, HP, Dell, Arista and so on.



With a comprehensive line of original-brand switches, we can recreate an environment and test each optics in practical application to ensure quality and distance.



The last test assured step to ensure our products to be shipped with perfect package.

Order Information

Part Number	Description
CVR-QSFP28-SFP28	100G QSFP28 to 25G SFP28 Adapter Converter Module
CVR-QSFP-SFP10G	40G QSFP+ to 10G SFP+ Adapter Converter Module

Notes:

1. Converter module is individually tested on corresponding equipment such as Cisco, Arista, Juniper, Dell, Brocade and other brands, and passes the monitoring of FS.COM intelligent quality control system.



 <https://www.fs.com>



The information in this document is subject to change without notice. FS has made all efforts to ensure the accuracy of the information, but all information in this document does not constitute any kind of warranty.