

# QSFP28 100GBASE Passive Loopback Testing Module

Q28-LB



## Application

- QSFP port/system testing
- Ethernet IEEE 802.3 (Gigabit, 10 Gigabit, 40 Gigabit, and 100 Gigabit Ethernet)
- SDR, DDR and QDR Infiniband Transmission
- SONET, SDH, GBE, Fiber Channel Support

## Features

- Customizable power consumption
- Custom memory maps available
- Supports 100Gbps total data rate
- Hot-pluggable MSA footprint
- Full SFF-8665 MSA compliant
- Temperature range from -20°C to 85°C
- Compliant with SONET, SDH, GBE, Fiber Channel
- MSA Compliant EEPROM
- Power Classes 1 through 7 are available

## Description

QSFP28 Electrical Passive Loopback has excellent signal integrity, It is used for economical and flexible 100Gbps QSFP28 port testing, board level system testing and power on validation.

The loopback module is packaged in a standard MSA housing compatible with all QSFP+/QSFP28 ports. Transmit data from the host is electrically routed, (internal to the loopback module), to the receive data outputs and back to the host. It provides an economical way to exercise QSFP/QSFP+ ports during R&D validation, production testing, and field testing.

## Product Specifications

### I. Recommended Operation Condition

Parameter	Symbol	Min	Typ.	Max	Units	Notes/Conditions
<b>Operating Temperature</b>	TA	-20		85	° C	1
<b>Supply Voltage</b>	VCC	3.1	3.3	3.5	V	
<b>Data Rate</b>		0		112	Gbps	Guaranteed to work at 28Gbps per lane
<b>Input/ Output Load Resistance</b>	RL	90	100	110	Ω	
<b>Jitter</b>			33		pS	2
<b>Power Level 0</b>				0	W	0 A
<b>Power Level 1</b>				1	W	0.3 A
<b>Power Level 2</b>				1.5	W	0.45 A
<b>Power Level 3</b>				2	W	0.60 A
<b>Power Level 4</b>				2.5	W	0.75 A
<b>Power Level 5</b>				3	W	0.91 A
<b>Power Level 6</b>				3.5	W	1.06 A
<b>Power Level 7</b>				5	W	1.18 A

**Notes:**

1. Ambient temperature with a minimum of 100 linear feet per minute of air flow
2. Measured with 25G BERT and QSFP28 Host Test Board

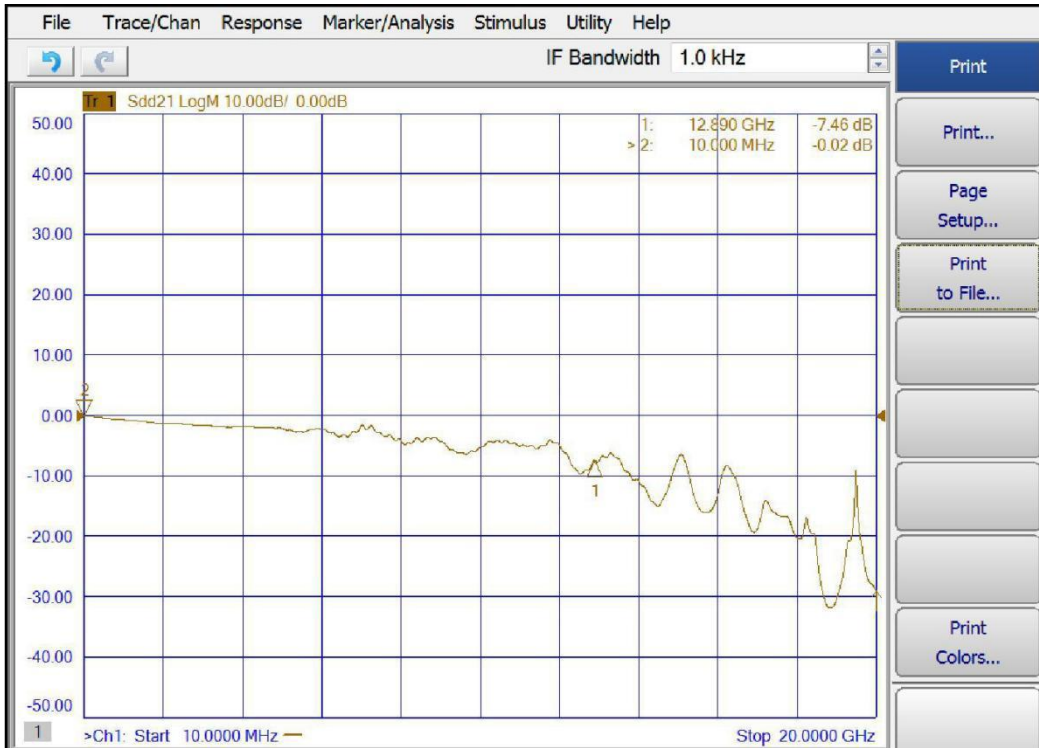

**SDD12-0dB (Transmit Insertion Loss)**

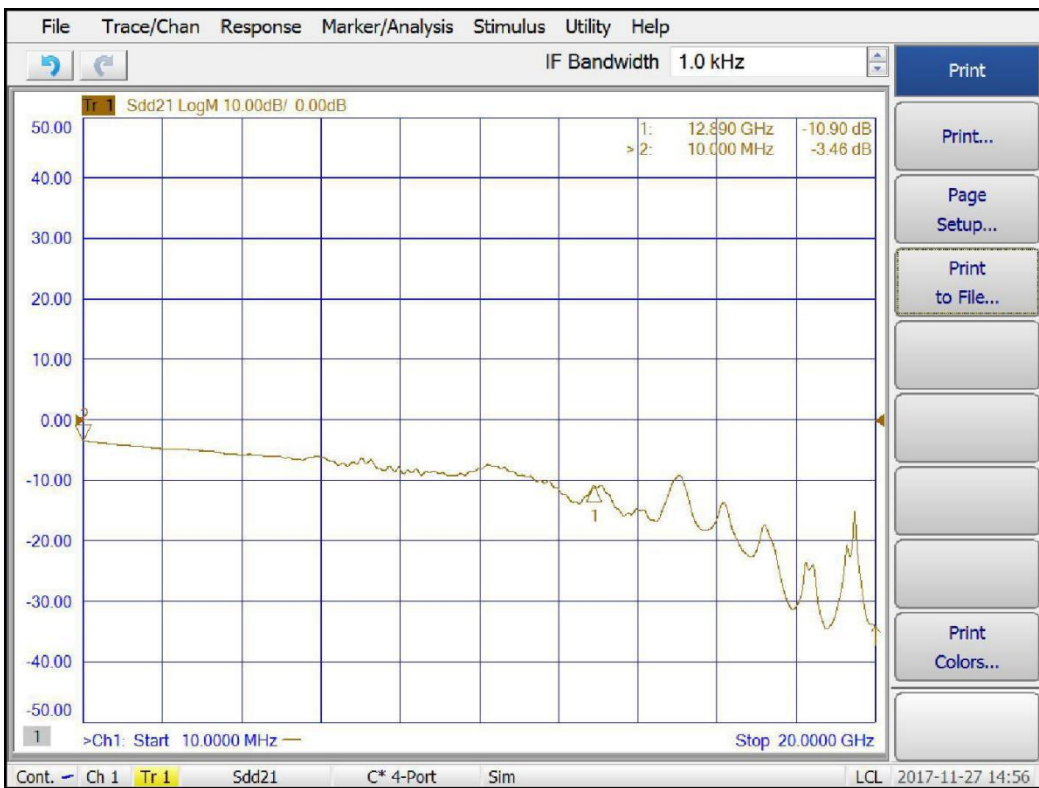

**SDD21-3.5dB (Transmit Insertion Loss)**

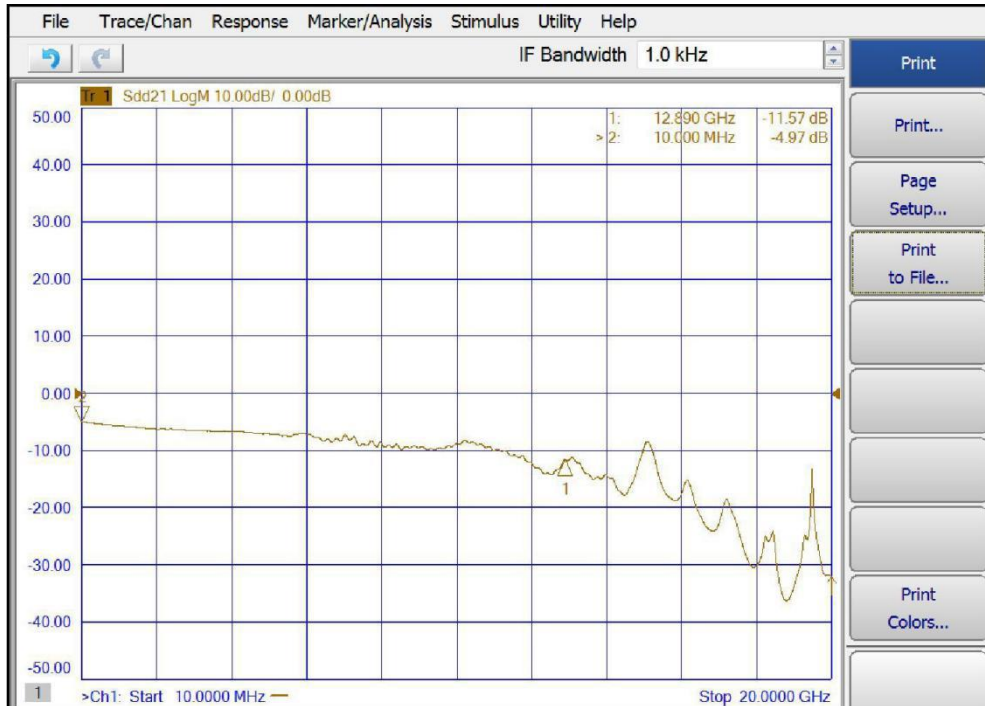

SDD21-5dB (Transmit Insertion Loss)

## II. Host Board Connector Pinout

Figure 1: MSA compliant Connector

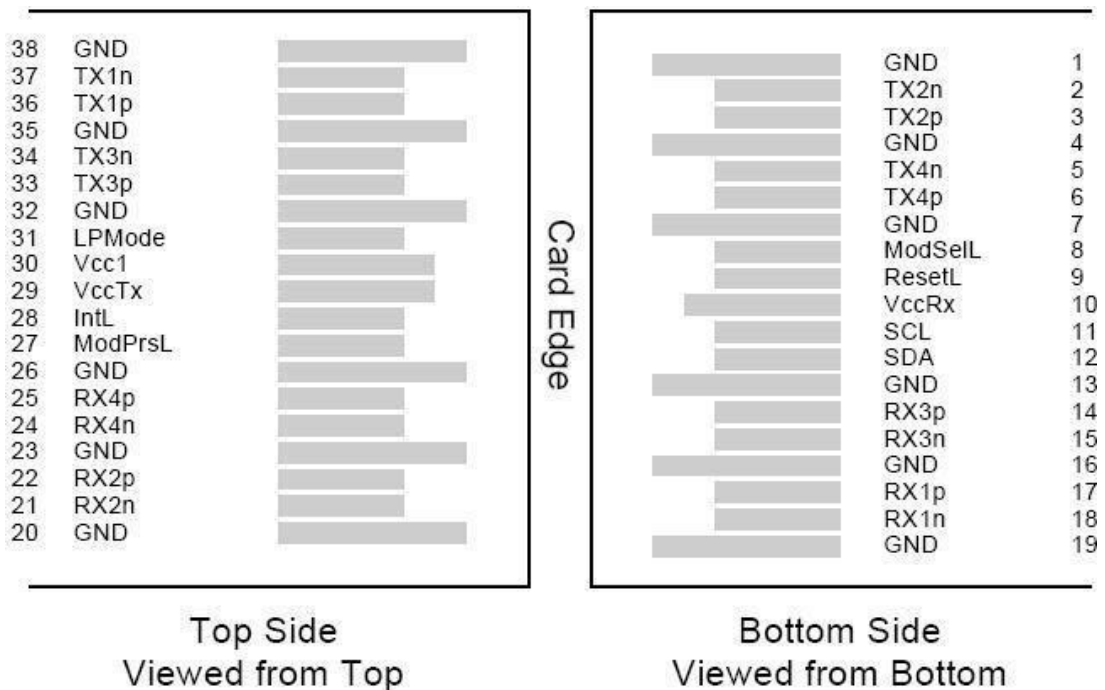

**Figure 2: Pin Definitions**

Pin	Logic	Symbol	Name/Description
1		GND	Ground
2	CML-I	Tx2n	Transmitter Inverted Data Input
3	CML-I	Tx2p	Transmitter Non-Inverted Data output
4		GND	Ground
5	CML-I	Tx4n	Transmitter Inverted Data Input
6	CML-I	Tx4p	Transmitter Non-Inverted Data output
7		GND	Ground
8	LVTTLL-I	ModSelL	Module Select
9	LVTTLL-I	ResetL	Module Reset
10		VccRx	+3.3V Power Supply Receiver
11	LVCNOS-I/O	SCL	2-Wire Serial Interface Clock
12	LVCNOS-I/O	SDA	2-Wire Serial Interface Data
13		GND	Ground
14	CML-O	Rx3p	Receiver Non-Inverted Data Output
15	CML-O	Rx3n	Receiver Inverted Data Output
16		GND	Ground
17	CML-O	Rx1p	Receiver Non-Inverted Data Output
18	CML-O	Rx1n	Receiver Inverted Data Output
19		GND	Ground
20		GND	Ground
21	CML-O	Rx2n	Receiver Inverted Data Output
22	CML-O	Rx2p	Receiver Non-Inverted Data Output
23		GND	Ground

24	CML-O	Rx4n	Receiver Inverted Data Output
25	CML-O	Rx4p	Receiver Non-Inverted Data Output
26		GND	Ground
27	LVTTTL-O	ModPrsL	Module Present
28	LVTTTL-O	IntL	Interrupt
29		VccTx	+3.3 V Power Supply transmitter
30		Vcc1	+3.3 V Power Supply
31	LVTTTL-I	LPMode	Low Power Mode
32		GND	Ground
33	CML-I	Tx3p	Transmitter Non-Inverted Data Input
34	CML-I	Tx3n	Transmitter Inverted Data Output
35		GND	Ground
36	CML-I	Tx1p	Transmitter Non-Inverted Data Input
37	CML-I	Tx1n	Transmitter Inverted Data Output
38		GND	Ground

**Notes:**

- 1.GND is the symbol for signal and supply (power) common for QSFP modules. All are common within the QSFP module and all module voltages are referenced to this potential otherwise noted. Connect these directly to the host board signal common ground plane.
- 2.Vcc Rx, Vcc1 and Vcc Tx are the receiver and transmitter power suppliers and shall be applied concurrently. Recommended host board power supply filtering is shown below. Vcc Rx, Vcc1 and Vcc Tx may be internally connected within the QSFP transceiver module in any combination.

### III. Memory Map

The memory map is structured as a single address and multiple page approaches, according to the QSFP+ SFF-8436 MSA specification as shown in the below. For more detailed description of this memory map or lower pages, please see our Memory Map document with flexible customization settings.

**Table 1: Memory Map (Specific Data Field Descriptions)**

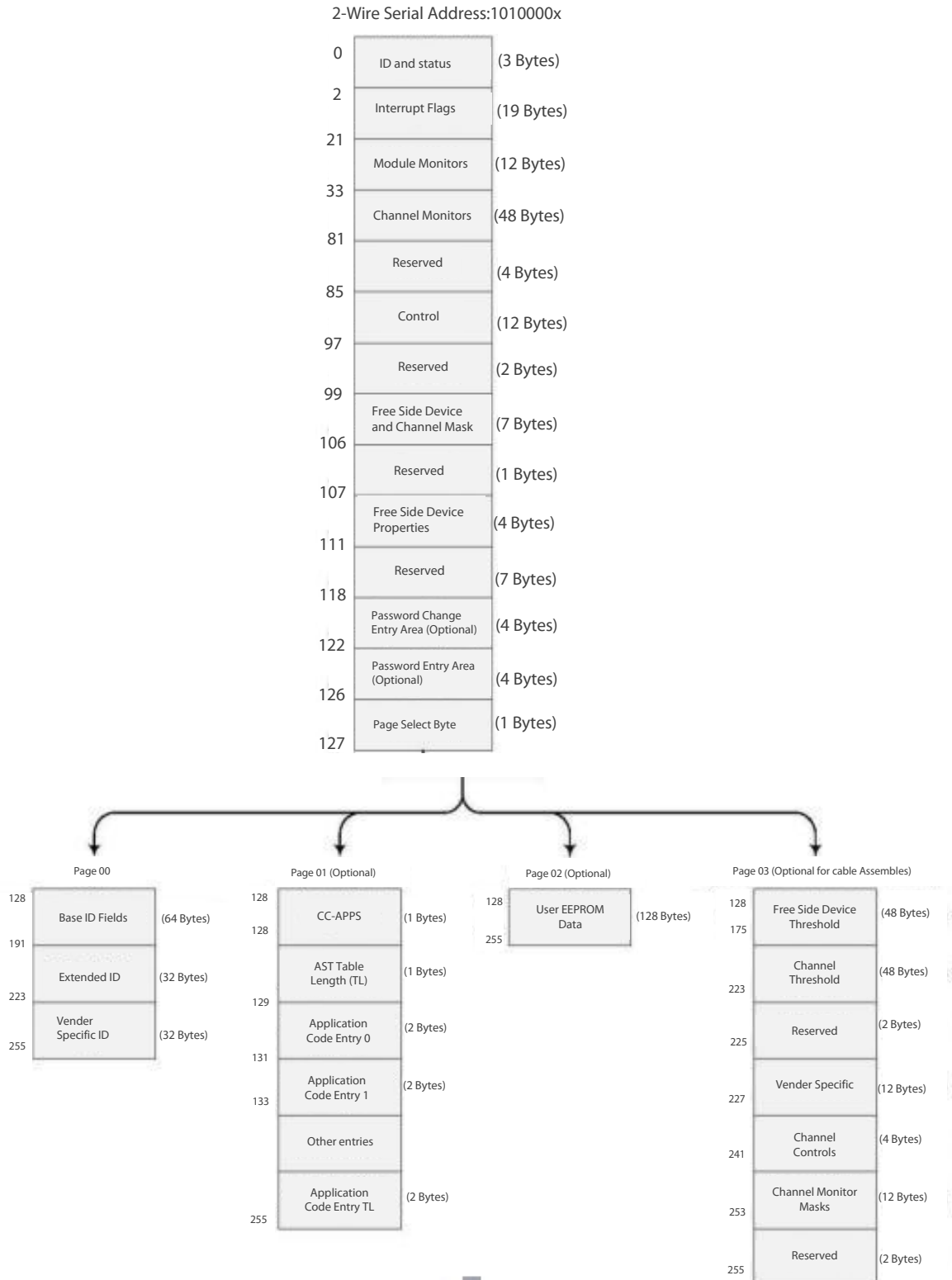

**Table 2: EEPROM Serial ID Memory Contents (Page00)**

Part Number		Q28-LB		
Device 0x Page00				
DATA Address (DEC)	DATA Address (HEX)	Value (HEX)	Name of Field	Description
128	80	0x11	Identifier	QSFP28
129	81	0x00	Ext. Identifier	
130	82	0x80	Connector Type	Vendor Specific
131	83	0x80	Specification Compliance	The Extended Specification Compliance Codes are maintained in the Transceiver Management section of SFF-8024
132	84	0x00		
133	85	0x00		
134	86	0x00		
135	87	0x41		Intermediate distance (I) Medium (M) Electrical inter-enclosure (EL)
136	88	0x80		Electrical intra-enclosure
137	89	0x80		Twin Axial Pair (TW)
138	8A	0xF5		Fibre Channel Speed
139	8B	0x05		Encoding
140	8C	0xFF	BR, Nominal	25.5GBs
141	8D	0x00	Rate Select Compliance	Unspecified
142	8E	0x00	Length (SMF)	Unspecified
143	8F	0x00	Length (OM3 50um)	Unspecified
144	90	0x00	Length (OM2 50um)	Unspecified



145	91	0x00	Length (OM1 62.5um)	Unspecified
146	92	0x00	Cable Assembly Length (Copper or active cable)	Unspecified
147	93	0x80	Device Technology	Transmitter technology
148	94	0x31		
149	95	0x30		
150	96	0x47		
151	97	0x74		
152	98	0x65		
153	99	0x6B		
154	9A	0x20		
155	9B	0x20		
156	9C	0x20		
157	9D	0x20		
158	9E	0x20		
159	9F	0x20		
160	A0	0x20		
161	A1	0x20		
162	A2	0x20		
163	A3	0x20		
164	A4	0x00	Extended Module Code Values	Unspecified

165	A5	0x00		
166	A6	0x00	Vendor OUI	Unspecified
167	A7	0x00		
168	A8	0x43		
169	A9	0x41		
170	AA	0x42		
171	AB	0x2D		
172	AC	0x5A		
173	AD	0x51		
174	AE	0x50		
175	AF	0x2D		
176	B0	0x4C		
177	B1	0x42		
178	B2	0x30		
179	B3	0x20		
180	B4	0x20		
181	B5	0x20		

182	B6	0x20		
183	B7	0x20		
184	B8	0x30		
185	B9	0x31	Vendor Rev	01
186	BA	0x00	Wavelength or Copper cable Attenuation	
187	BB	0x00		
188	BC	0x00	Wavelength Tolerance or Copper Cable Attenuation	Unspecified
189	BD	0x00		
190	BE	0x55	Max case Temp.	85°C
191	BF	0x00	CC_BASE	
192	C0	0x0B	Link Codes	100GBASE-CR4
193	C1	0x00		
194	C2	0x00	Options	Unspecified
195	C3	0x00		
196	C4	0x53		
197	C5	0x31		
198	C6	0x38		

199	C7	0x30		
200	C8	0x38		
201	C9	0x30		
202	CA	0x31		
203	CB	0x30		
204	CC	0x30		
205	CD	0x30		
206	CE	0x31		
207	CF	0x20		
208	D0	0x20		
209	D1	0x20		
210	D2	0x20		
211	D3	0x20		
212	D4	0x31		
213	D5	0x38		
214	D6	0x30		
215	D7	0x38		
216	D8	0x30	Date Code	180801
217	D9	0x31		
218	DA	0x20		
219	DB	0x20		

220	DC	0x00	Diagnostic Monitoring Type	Unsupported
221	DD	0x00	Enhanced Options	Unspecified
222	DE	0x00	BR, nominal	Unspecified
224	E0		CC_EXT	
225	E1			
226	E2			
227	E3			
228	E4			
229	E5			
230	E6			
231	E7			
232	E8			
233	E9		Vendor Specific	Unspecified
234	EA			
235	EB			
236	EC			
237	ED			
238	EE			
239	EF			
240	F0			
241	F1			

248	F8		
249	F9		
250	FA		
251	FB	Vendor Specific	Unspecified
252	FC		
253	FD		
254	FE		
255	FF		

### IV. Mechanical Specifications

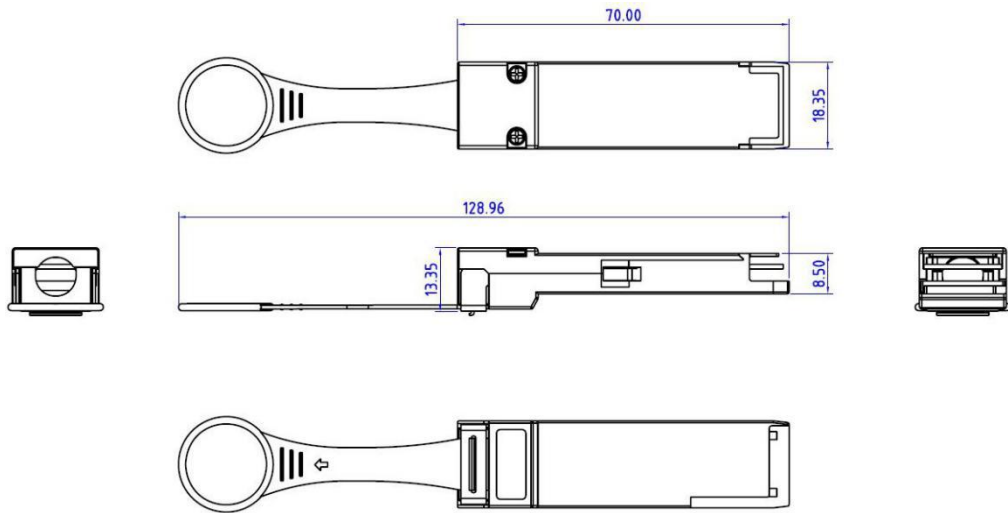

## Test Center

FS.COM transceivers are tested to ensure connectivity and compatibility in our test center before shipped out. FS.COM test center is supported by a variety of mainstream original brand switches and groups of professional staff, helping our customers make the most efficient use of our products in their systems, network designs and deployments.

The original switches could be found nowhere but at FS.COM test center, eg: Juniper MX960 & EX 4300 series, Cisco Nexus 9396PX & Cisco ASR 9000 Series, HP 5900 Series & HP 5406R ZL2 V3(J9996A), Arista 7050S-64, Brocade ICX7750-26Q & ICX6610-48, Avaya VSP 7000 MDA 2, etc.



Cisco ASR 9000 Series(A9K-MPA-1X40GE)



ARISTA 7050S-64(DCS-7050S-64)



Juniper MX960



Brocade ICX 7750-26Q



Extreme Networks X670V VIM-40G4X



Mellanox M3601Q



Dell N4032F



HP 5406R ZL2 V3(J9996A)



AVAYA 7024XLS(7002QQ-MDA)

## Test Assured Program

FS.COM truly understands the value of compatibility and interoperability to each optics. Every module FS.COM provides must run through programming and an extensive series of platform diagnostic tests to prove its performance and compatibility. In our test center, we care of every detail from staff to facilities—professionally trained staff, advanced test facilities and comprehensive original-brand switches, to ensure our customers to receive the optics with superior quality.



Our smart data system allows effective product management and quality control according to the unique serial number, properly tracing the order, shipment and every part.

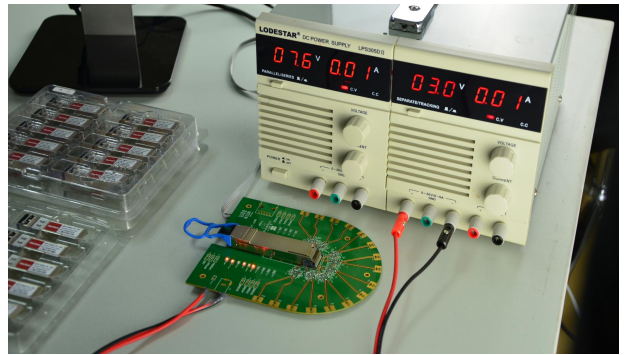

Our in-house coding facility programs all of our parts to standard OEM specs for compatibility on all major vendors and systems such as Cisco, Juniper, Brocade, HP, Dell, Arista and so on.



With a comprehensive line of original-brand switches, we can recreate an environment and test each optics in practical application to ensure quality and distance.



The last test assured step to ensure our products to be shipped with perfect package.



## Order Information

Part Number	Description
Q28-LB	QSFP28 Passive Loopback Testing Module, 0dB, 0W
QSFP-LB	QSFP+ Passive Loopback Testing Module, 0dB, 0W
10GSFP-LPM	SFP+ Passive Loopback Testing Module, 0dB, 0W

**Notes:**

100G QSFP28 Passive Loopback Testing Module is individually tested on corresponding equipment such as Cisco, Arista, Juniper, Dell, Brocade and other brands, and passes the monitoring of FS.COM intelligent quality control system.



 <https://www.fs.com>



The information in this document is subject to change without notice. FS has made all efforts to ensure the accuracy of the information, but all information in this document does not constitute any kind of warranty.