

# 100GBASE-BX20 QSFP28 1280nm-TX/1310nm-RX 20km DOM Transceiver

QSFP28-100G-BX20

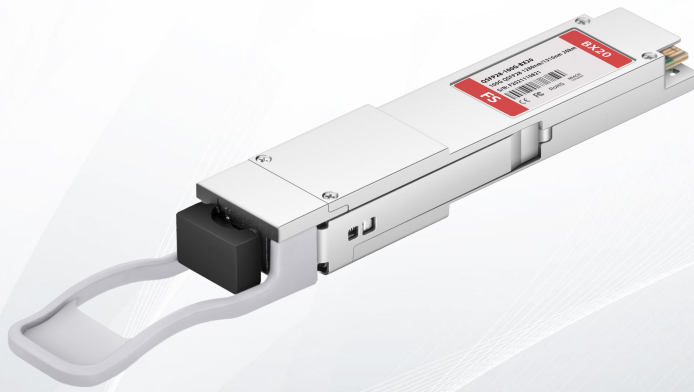

## Application

- Ethernet Links
- 100G 4WDM-20 applications with FEC

## Features

- Hot pluggable QSFP28 MSA form factor
- Supports 103.1Gb/s aggregate bit rate
- Up to 20km reach for G.652 SMF [with RS(528,514) FEC]
- Single +3.3V power supply
- Extended case temperature range of -20°C to 85°C
- Cooled 4x25Gb/s LAN WDM Blue or Red Side TOSA, LAN WDM Red or Blue Side ROSA
- Maximum power consumption 5W
- Single LC receptacle
- Compliant with the QSFP28 and 4WDM-20 MSA
- Compatible with RoHS2.0
- DDM function

## Product Specifications

### I. Absolute Maximum Ratings

Parameter	Symbol	Unit	Min	Max
Transportation and Storage Temperature Range	T <sub>s</sub>	°C	-40	85
Transportation and Storage Relative Humidity	RH	%	5	95
Power Supply Voltage	V <sub>cc</sub>	V	-0.3	+3.6
Case Temperature Range when module is powered on Ready State	T <sub>c</sub>	°C	-20	85
Mean Receiver Damage Threshold Per Lane	P <sub>dag</sub>	dBm		+6.0
ESD(HBM)		V		1000

### II. Recommended Operating Conditions

Parameter	Symbol	Unit	Min	Typ	Max
Operating Case Temperature Range	T <sub>c</sub>	°C	-20		85
Relative Humidity	RH	%	0		90
Power Supply Voltage	V <sub>cc</sub>	V	3.135	3.3	3.465
Total Power Consumption	P <sub>w</sub>	W			5.5
Data rate(each line)		Gb/s		25.78125	-

### III. Voltage Supply Electrical Characteristics

Parameter	Symbol	Unit	Min	Typ	Max	Notes
<b>Steady State Supply Current</b>	I <sub>cc</sub>	mA			1443.0	
<b>Sustained peak current</b>	I <sub>sp</sub>	mA			1650	
<b>Instantaneous peak current</b>	I <sub>ip</sub>	90			2000	
<b>Power Dissipation</b>	P <sub>w</sub>	W			5.5	
<b>Low Power Dissipation</b>	P <sub>low</sub>	W			1.5	

### IV. Different Signal Electrical Characteristics

Parameter	Symbol	Unit	Min	Typ	Max	Notes
<b>Transmitter (CEI-28G-VSR)</b>						
<b>Differential voltage pk-pk</b>		mV			900	
<b>Common mode noise (rms)</b>		mV			17.5	
<b>Eye height</b>		mV	95			
<b>Eye width</b>		Ui	0.46			
<b>Differential termination mismatch</b>		%			10	
<b>Transition time</b>		ps	10			20/80%
<b>Common mode voltage</b>		V	-0.3		2.8	

**Receiver(CEI-28G-VSR)**

<b>Differential voltage pk-pk</b>		mV			900	
<b>Common mode noise (rms)</b>		mV			17.5	
<b>Eye height</b>		mV	228			
<b>Eye width</b>		Ui	0.57			
<b>Differential termination mismatch</b>		%			10	
<b>Transition time</b>		ps	9.5			20/80%
<b>Vertical eye closure</b>		dB			5.5	

**V. 3.3V LVTTTL Electrical Characteristics**

Parameter	Symbol	Unit	Min	Typ	Max	Notes
<b>Input High Voltage</b>	V <sub>IH</sub>	V	2.0		V <sub>CC</sub> +0.3	
<b>Input Low Voltage</b>	V <sub>IL</sub>	V	-0.3		0.8	V <sub>IL</sub>
<b>Input Leakage Current</b>	I <sub>IN</sub>	uA	-10		+10	I <sub>IN</sub>
<b>Output High Voltage (I<sub>OH</sub>=100uA)</b>	V <sub>OH</sub>	V	V <sub>CC</sub> -0.5		V <sub>CC</sub> +0.3	V <sub>OH</sub>
<b>Output Low Voltage (I<sub>OL</sub>=100uA)</b>	V <sub>OL</sub>	V	0		0.4	V <sub>OL</sub>

## VI. 3V LVCMOS Electrical Characteristics

Parameter	Symbol	Unit	Min	Typ	Max	Notes
<b>Input High Voltage</b>	V <sub>IH</sub>	V	V <sub>CC</sub> *0.7		V <sub>CC</sub> +0.5	
<b>Input Low Voltage</b>	V <sub>IL</sub>	V	-0.3		V <sub>CC</sub> *0.3	
<b>Output High Voltage (I<sub>OH</sub>=100uA)</b>	V <sub>OH</sub>	V	V <sub>CC</sub> -0.5		V <sub>CC</sub> +0.3	
<b>Output Low Voltage (I<sub>OL</sub>=100uA)</b>	V <sub>OL</sub>	V	0		0.4	
<b>I/O Pin Capacitance</b>	C <sub>i</sub>	pF			14	

## VII. OPTIC SPECIFICATION

Parameter	Symbol	Unit	Min	Typ	Max	Notes
-----------	--------	------	-----	-----	-----	-------

### Optical transmitter Characteristics

<b>Signaling Rate for Each Lane</b>		Gbps		25.78125		
<b>Signaling Speed Accuracy</b>		ppm	-100		+100	
<b>Blue Side Four Lane Wavelength Range</b>	λ <sub>1</sub>	nm	1272.55	1273.55	1274.54	
	λ <sub>2</sub>		1276.89	1277.89	1278.89	
	λ <sub>3</sub>		1281.25	1282.26	1283.27	
	λ <sub>4</sub>		1285.65	1286.66	1287.68	
<b>Red Side Four Lane Wavelength Range</b>	λ <sub>5</sub>	nm	1294.53	1295.56	1296.59	
	λ <sub>6</sub>		1299.02	1300.05	1301.09	
	λ <sub>7</sub>		1303.54	1304.58	1305.63	
	λ <sub>8</sub>		1308.09	1309.14	1310.19	

<b>Side Mode Suppression Ratio (min)</b>	SMSR		30			
<b>Total Average Launch Power</b>	Pt	dBm			10.5	
<b>Average Launch Power for Each Lane</b>	Pa	dBm	-4.3		+4.5	1
<b>Optical Modulation Amplitude for Each Lane</b>	OMA	dBm	-1.3		4.5	2
<b>Launch power in OMA minus TDP, per Lane(min)</b>		dB	-2.3			
<b>Difference in launch power between any two lanes (OMA) (max)</b>		dB			5.0	
<b>Transmitter and Dispersion Penalty for Each Lanes</b>	TDP	dB			2.8	4
<b>Average Launch Power of Off Transmitter for Each Lanes</b>	Poff	dBm			-30	
<b>Extinction Ratio</b>	EX	dB	4			
<b>Optical Return Loss Tolerance</b>		dB			20	
<b>Transmitter Reflectance</b>		dB			-26	3
<b>Eye Diagram</b>			{0.25, 0.4, 0.45, 0.25, 0.28, 0.4}			5
<b>Eye mask margin</b>			≥10%			
<b>Optical path&amp;Power budget</b>						
<b>Power budget (for max TDP)</b>		dB			13	
<b>Operating distance</b>		km	20			
<b>Channel insertion loss</b>		dB	0		10.2	
<b>Maximum discrete reflectance</b>		dB			-26	

<b>Allocation for penalties (for max TDP)</b>		dB			2.8	
<b>Dispersion @Blue side Neg</b>		ps/nm	-102		-70	
<b>Dispersion @Blue side Pos</b>		ps/nm	-53		-23	
<b>Dispersion @Red side Neg</b>		ps/nm	-53		-26	
<b>Dispersion @Red side Pos</b>		ps/nm	-10		19	

**Optical receiver Characteristics**

<b>Receive Rate for Each Lane</b>	Gbps			25.78125		
<b>Signaling Speed Accuracy</b>	ppm		-100		+100	
<b>Red Side Four Lane Wavelength Range</b>	$\lambda 5$		1294.53	1295.56	1296.59	
	$\lambda 6$	nm	1299.02	1300.05	1301.09	
	$\lambda 7$		1303.54	1304.58	1305.63	
	$\lambda 8$		1308.09	1309.14	1310.19	
<b>Blue Side Four Lane Wavelength Range</b>	$\lambda 1$			1272.55	1273.55	1274.54
	$\lambda 2$		1276.89	1277.89	1278.89	
	$\lambda 3$	nm	1281.25	1282.26	1283.27	
	$\lambda 4$		1285.65	1286.66	1287.68	
<b>Overload Input Optical Power</b>	Pmax	dBm	5.5			6
<b>Average Receive Power for Each Lane</b>	Pin		-14.5		4.5	7
<b>Receive Power In OMA for Each Lane</b>	PinOMA	dBm			4.5	
<b>Receiver reflectance</b>		dB			-26	

<b>Receiver Sensitivity in OMA for Each Lane(100GbE) at BER= 5x10<sup>-5</sup> BER</b>	$S_{OMA}$	dBm			-12.5	8
<b>Stressed Receiver Sensitivity in OMA for Each Lane</b>		dBm			-10.0	9
<b>RX Los Assert level</b>	The assert level occurs for the RX input power to a lane corresponding to an equivalent BER of 1E-2 to 1E-4					
<b>Los Hysteresis</b>		dBm	0.5			

**Note:**

1. Average launch power, each lane (min) is informative and not the principal indicator of signal strength. A transmitter with launch power below this value cannot be compliant; however, a value above this does not ensure compliance.
2. Even if the TDP<1dB, the OMA (min) must exceed this value.
3. Transmitter reflectance is defined looking into the transmitter.
4. TDP does not include a penalty for multi-path interference (MPI).
5. Eye mask hit ratio is 5E-5.
6. The receiver shall be able to tolerate, without damage, continuous exposure to an optical input signal having this average power level.
7. Average receive power, each lane (min) is informative and not the principal indicator of signal strength. A received power below this value cannot be compliant; however, a value above this does not ensure compliance.
8. Receiver sensitivity (OMA), each lane (max) at 5 x 10<sup>-5</sup> BER is a normative specification.
9. Measured with conformance test signal at TP3 (Refer to IEEE Std 802.3™-2015 Cl. 88.8.10) for BER = 5x10<sup>-5</sup>.



### VIII. HARDWARE CHARACTERS

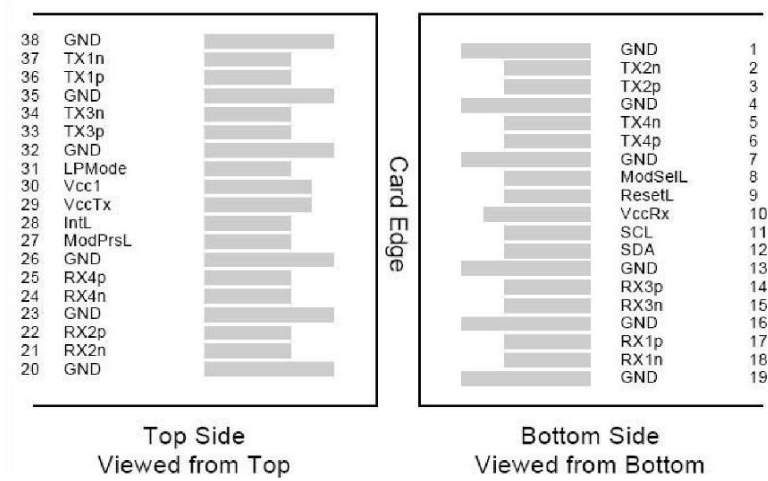

PIN	DEFINITION	DESCRIPTION	NOTE
1	GND	Ground	1
2	Tx2n	TransmitterInvertedDataInput	
3	Tx2p	TransmitterNon-InvertedDataInput	
4	GND	Ground	1
5	Tx4n	TransmitterInvertedDataInput	
6	Tx4p	TransmitterNon-InvertedDataInput	
7	GND	Ground	1
8	ModSelL	ModuleSelect	
9	ResetL	ModuleReset	
10	VccRx	+3.3VPowerSupplyReceiver	2
11	SCL	2-WireSerialInterfaceClock	
12	SDA	2-WireSerialInterfaceData	

14	Rx3p	ReceiverNon-InvertedDataOutput	
15	Rx3n	ReceiverInvertedDataOutput	
16	GND	Ground	1
17	Rx1p	ReceiverNon-InvertedDataOutput	
18	Rx1n	ReceiverInvertedDataOutput	
19	GND	Ground	1
20	GND	Ground	1
21	Rx2n	ReceiverInvertedDataOutput	
22	Rx2p	ReceiverNon-InvertedDataOutput	
23	GND	Ground	1
24	Rx4n	ReceiverInvertedDataOutput	
25	Rx4p	ReceiverNon-InvertedDataOutput	
26	GND	Ground	1
27	ModPrsL	ModulePresent	
28	IntL/RxLosL	Interrupt.OptionallyconfigurableasRxLOSManagementinterface(SFF-8636).	
29	VccTx	+3.3VPowerSupplytransmitter	2
30	Vcc1	+3.3VPowerSupply	2
31	LPMMode	LowPowerMode.OptionallyconfigurableasTxDisviathemanagementinterface(SFF-8636).	
32	GND	Ground	1
33	Tx3p	TransmitterNon-InvertedDataInput	

35	GND	Ground	1
36	Tx1p	TransmitterNon-InvertedDataInput	
37	Tx1n	TransmitterInvertedDataInput	
38	GND	Ground	1

**Note:**

1. GND is the symbol for signal and supply (power) common for the QSFP28 module. All are common within the module and all module voltages are referenced to this potential unless otherwise noted. Connect these directly to the host board signal common ground plane.
2. VccRx, Vcc1 and VccTx are the receiving and transmission power suppliers and shall be applied concurrently. Recommended host board power supply filtering is shown in Figure 3 below. Vcc Rx, Vcc1 and Vcc Tx may be internally connected within the module in any combination. The connector pins are each rated for a maximum current of 1000mA.

**IX. DDM accuracy**

Parameters	Unit	Requirements	Note
Temperature	°C	+/-3	
Voltage	V	+/-5%	
Rx power	dB	+/-3.0	
Tx power	dB	+/-3.0	

**X. DDM Alarm & warning threshold is listed below**

Parameters	Unit	Requirements	Description
Temp low warning	°C	-40	Min.casetemperature
Temp high warning	°C	85	Max.casetemperature
Voltage low warning	V	3.135	-5%Vcctarget
Voltage high warning	V	3.465	+5%Vcctarget
Tx power low warning	dBm	-4.3	
Tx power high warning	dBm	4.5	
Rx power low warning	dBm	-12.7	
Rx power high warning	dBm	4.5	
Temp low alarm	°C	-43	
Temp high alarm	°C	88	
Voltage low alarm	V	3.041	
Voltage high alarm	V	3.569	
Tx power low alarm	dBm	-6.3	
Tx power high alarm	dBm	6.5	
Rx power low alarm	dBm	-14.7	
Rx power high alarm	dBm	6.5	

## XI. RECOMMEND CIRCUIT

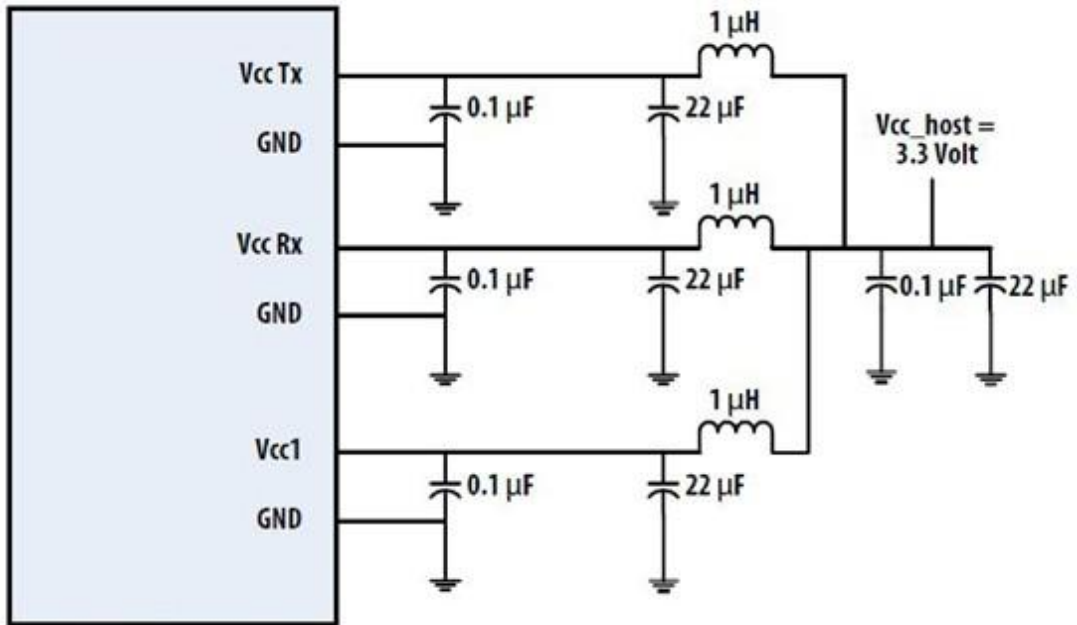

## XII. MECHANICAL DRAWINGS

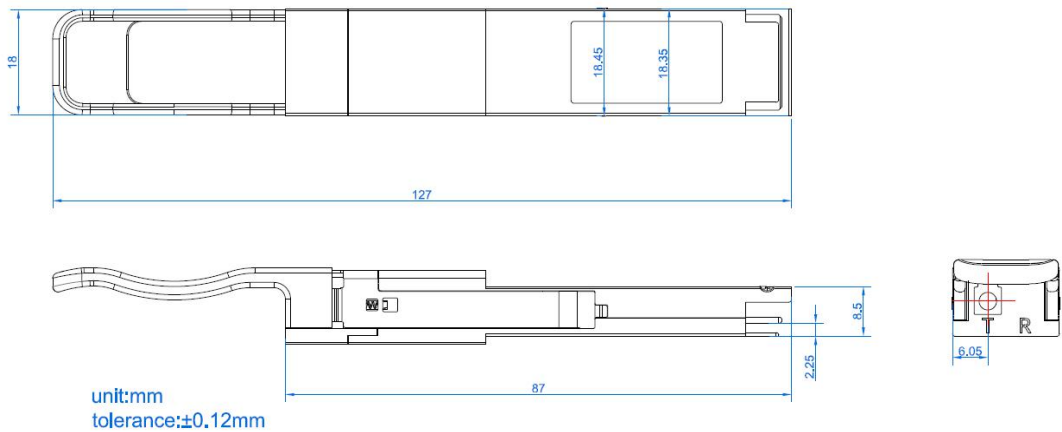

## Test Center

FS.COM transceivers are tested to ensure connectivity and compatibility in our test center before shipped out. FS.COM test center is supported by a variety of mainstream original brand switches and groups of professional staff, helping our customers make the most efficient use of our products in their systems, network designs and deployments.

The original switches could be found nowhere but at FS.COM test center, eg: Juniper MX960 & EX 4300 series, Cisco Nexus 9396PX & Cisco ASR 9000 Series, HP 5900 Series & HP 5406R ZL2 V3(J9996A), Arista 7050S-64, Brocade ICX7750-26Q & ICX6610-48, Avaya VSP 7000 MDA 2, etc.



Cisco ASR 9000 Series(A9K-MPA-1X40GE)



ARISTA 7050S-64(DCS-7050S-64)



Juniper MX960



Brocade ICX 7750-26Q



Extreme Networks X670V VIM-40G4X



Mellanox M3601Q



Dell N4032F



HP 5406R ZL2 V3(J9996A)



AVAYA 7024XLS(7002QQ-MDA)

## Test Assured Program

FS.COM truly understands the value of compatibility and interoperability to each optics. Every module FS.COM provides must run through programming and an extensive series of platform diagnostic tests to prove its performance and compatibility. In our test center, we care of every detail from staff to facilities—professionally trained staff, advanced test facilities and comprehensive original-brand switches, to ensure our customers to receive the optics with superior quality.



Our smart data system allows effective product management and quality control according to the unique serial number, properly tracing the order, shipment and every part.

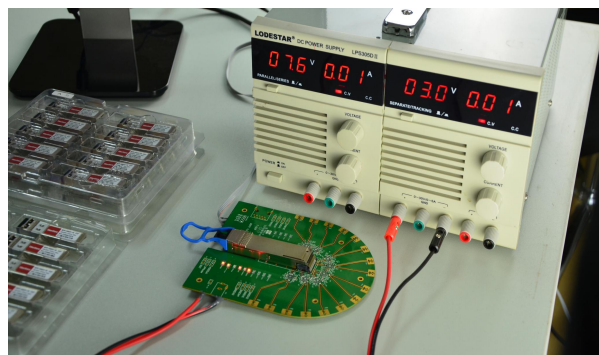

Our in-house coding facility programs all of our parts to standard OEM specs for compatibility on all major vendors and systems such as Cisco, Juniper, Brocade, HP, Dell, Arista and so on.



With a comprehensive line of original-brand switches, we can recreate an environment and test each optics in practical application to ensure quality and distance.



The last test assured step to ensure our products to be shipped with perfect package.

## Order Information

Part Number	Description
QSFP28-100G-BX20	QSFP28 100GBASE-BX20 1280NM-TX/1310NM-RX 20KM TRANSCEIVER
QSFP28-100G-BX20	QSFP28 100GBASE-BX20 1310NM-TX/1280NM-RX 20KM TRANSCEIVER





 <https://www.fs.com>



The information in this document is subject to change without notice. FS has made all efforts to ensure the accuracy of the information, but all information in this document does not constitute any kind of warranty.