

Description

I. General Description

This product is a 100Gb/s transceiver module designed for optical communication applications compliant to 100GBASE-LR4 of the IEEE P802.3ba and OTU4 411-9D1F standard. The module converts 4 input channels of 25Gb/s electrical data to 4 channels of LAN WDM optical signals and then multiplexes them into a single channel for 100Gb/s optical transmission. Reversely on the receiver side, the module de-multiplexes a 100Gb/s optical input into 4 channels of LAN WDM optical signals and then converts them to 4 output channels of electrical data.

The central wavelengths of the 4 LAN WDM channels are 1295.56, 1300.05, 1304.58 and 1309.14 nm as members of the LAN WDM wavelength grid defined in IEEE 802.3ba. The high performance cooled LAN WDM DFB transmitters and high sensitivity PIN receivers provide superior performance for 100Gigabit Ethernet applications up to 10km links and compliant to optical interface with IEEE802.3ba Clause 88 100GBASE-LR4 requirements.

The product is designed with form factor, optical/electrical connection and digital diagnostic interface according to the QSFP+ Multi-Source Agreement (MSA). It has been designed to meet the harshest external operating conditions including temperature, humidity and EMI interference.

II. Functional Description

The transceiver module receives 4 channels of 25Gb/s electrical data, which are processed by a 4-channel Clock and Data Recovery (CDR) IC that reshapes and reduces the jitter of each electrical signal. Subsequently, each of 4 DML laser driver IC's converts one of the 4 channels of electrical signals to an optical signal that is transmitted from one of the 4 cooled DML lasers which are packaged in the Transmitter Optical Sub-Assembly (TOSA). Each laser launches the optical signal in specific wavelength specified in IEEE802.3ba 100GBASE-LR4 requirements. These 4-lane optical signals will be optically multiplexed into a single fiber by a 4-to-1 optical WDM MUX. The optical output power of each channel is maintained constant by an automatic power control (APC) circuit. The transmitter output can be turned off by TX_DIS hardware signal and/or 2-wire serial interface.

The receiver receives 4-lane LAN WDM optical signals. The optical signals are de-multiplexed by a 1-to-4 optical DEMUX and each of the resulting 4 channels of optical signals is fed into one of the 4 receivers that are packaged into the Receiver Optical Sub-Assembly (ROSA). Each receiver converts the optical signal to an electrical signal. The regenerated electrical signals are retimed and de-jittered and amplified by the RX portion of the 4-channel CDR. The retimed 4-lane output electrical signals are compliant with IEEE CAUI-4 interface requirements. In addition, each received optical signal is monitored by the DOM section. The monitored value is reported through the 2-wire serial interface. If one or more received optical signal is weaker than the threshold level, RX_LOS hardware alarm will be triggered.

A single +3.3V power supply is required to power up this product. Both power supply pins VccTx and VccRx are internally connected and should be applied concurrently. As per MSA specifications the module offers 7 low speed hardware control pins (including the 2-wire serial interface): ModSelL, SCL, SDA, ResetL, LPMode, ModPrsL and IntL.

Module Select (ModSelL) is an input pin. When held low by the host, this product responds to 2-wire serial communication commands. The ModSelL allows the use of this product on a single 2-wire interface bus— individual ModSelL lines must be used. Serial Clock (SCL) and Serial Data (SDA) are required for the 2-wire serial bus communication interface and enable the host to access the QSFP28 memory map. The ResetL pin enables a complete reset, returning the settings to their default state, when a low level on the ResetL pin is held for longer than the minimum pulse length. During the execution of a reset the host shall disregard all status bits until it indicates a completion of the reset interrupt. The product indicates this by posting an IntL (Interrupt) signal with the Data_Not_Ready bit negated in the memory map. Note that on power up (including hot insertion) the module should post this completion of reset interrupt without requiring a reset.

Low Power Mode (LPMode) pin is used as TX disable. If the LPMode pin is in the high state, the modulator will tune off the Laser.

Module Present (ModPrsL) is a signal local to the host board which, in the absence of a product, is normally pulled up to the host Vcc. When the product is inserted into the connector, it completes the path to ground through a resistor on the host board and asserts the signal. ModPrsL then indicates its present by setting ModPrsL to a "Low" state. Interrupt (IntL) pin is used as RX-LOS. When "Low", it indicates a RX-LOS assert. Other alarm asserting does not go through IntL pin.

Product Specifications

I. Absolute Maximum Ratings

It has to be noted that the operation in excess of any individual absolute maximum ratings might cause permanent damage to this module.

Parameter	Symbol	Min	Typ.	Max	Unit	Note
Storage Temperature	T_S	-40		85	° C	
Case Operating Temperature	T_{OP}	0		70	° C	
Power Supply Voltage	V_{CC}	-0.5		3.6	V	
Relative Humidity	RH	0		85	%	
Damage Threshold, each Lane	TH_d	5.5			dBm	

II. Recommended Operating Conditions and Power Supply Requirements

Parameter	Symbol	Min	Typ.	Max	Unit
Case Operating Temperature	T_{OP}	0		70	° C
Power Supply Voltage	V_{CC}	3.135	3.3	3.465	V
Data Rate, each Lane		25.78		27.95	Gb/s
Control Input Voltage High		2		V_{CC}	V
Control Input Voltage Low		0		0.8	V
Link Distance with G.652	D	0.002		10	km

III. Electrical Characteristics (VCC = 3.14 to 3.46 Volts)

The following electrical characteristics are defined over the Recommended Operating Environment unless otherwise specified.

Parameter	Symbol	Min	Typ.	Max	Unit	Note
Supply Current	I_{CC}			1.12	A	
Power Consumption				3.5	W	

Transmitter (each lane)

Input Differential Impedance	Z_{in}	90	100	110	Ohm	
Differential Input Voltage Swing	$V_{in,pp}$			900	mVpp	

Receiver (each lane)

Differential Output Voltage Swing	Vout,pp	100		400	mVpp	1
		300		600		
		400		800		
		600		1200		
Differential Output Impedance	Zout	90	100	110	Ohm	

Notes:

1. Output voltage is settable in 4 discrete ranges via I2C. Default range is 400 – 800mV.

IV. Optical Characteristics (VCC = 3.14 to 3.46 V)**QSFP28 100GBASE-LR4**

Parameter	Symbol	Min	Typ.	Max	Unit	Note
Signaling Speed per Channel			25.78125		Gbps	
Lane Wavelength	L0	1294.53	/	1296.59	nm	
	L1	1299.02	/	1301.09	nm	
	L2	1303.54	/	1305.63	nm	
	L3	1308.09	/	1310.19	nm	
Transmitter						
Side Mode Suppression Ratio	SMSR	30			dB	
Total Average Launch Power	P _T			10.5	dBm	
Average Launch Power, each lane	P _{AVE}	-4.3		4.5	dBm	
OMA, each Lane	P _{OMA}	-1.3		4.5	dBm	
Difference in Launch Power between any Two Lanes (OMA)	P _{tx,diff}			5	dB	
Launch Power in OMA minus Transmitter and Dispersion Penalty (TDP), each Lane		-2.3			dBm	
TDP, each Lane	TDP			2.2	dB	
Extinction Ratio	ER	4			dB	
RIN20OMA	RIN			-130	dB/Hz	
Optical Return Loss Tolerance	TOL			20	dB	

Transmitter Reflectance	R_T			-12	dB		
Eye Mask{X1, X2, X3, Y1, Y2, Y3}				{0.25, 0.4, 0.45, 0.25, 0.28, 0.4}		1	
Average Launch Power OFF Transmitter, each Lane	P_{off}			-30	dBm		
Receiver							
Signaling Speed per Channel			25.78125		Gbps		
Lane Wavelength	L0	1294.53	/	1296.59	nm		
	L1	1299.02	/	1301.09	nm		
	L2	1303.54	/	1305.63	nm		
	L3	1308.09	/	1310.19	nm		
Total Average Receive Power				10.5	dBm		
Average Receive Power, each Lane			-10.6		4.5	dBm	
Receive Power (OMA), each Lane					4.5	dBm	
Receiver Sensitivity , each Lane	SEN				-8.6	dBm	2
Stressed Receiver Sensitivity (OMA), each Lane					-6.8	dBm	
Difference in Receive Power between any Two Lanes (OMA)	$P_{rx,diff}$				5.5	dB	
LOS Assert	LOS_A	-25				dBm	
LOS De-assert	LOS_D				-13	dBm	
LOS Hysteresis	LOS_H	0.5			6	dB	

Notes:

1. Compliant to IEEE 802.3ba.
2. Measured with conformance test signal at receiver input for BER = 1×10^{-12} .

QSFP28 OTU4

Parameter	Symbol	Min	Typ.	Max	Unit	Note
Signaling Speed per Channel			27.95		Gbps	
Lane Wavelength	L0	1294.53	/	1296.59	nm	
	L1	1299.02	/	1301.09	nm	
	L2	1303.54	/	1305.63	nm	
	L3	1308.09	/	1310.19	nm	

Transmitter

Side Mode Suppression Ratio	SMSR	30			dB	
Total Average Launch Power	P_T			10	dBm	
Average Launch Power, each lane	P_{AVE}	-0.6		4	dBm	
Channel Power Difference	$P_{out,diff}$			5	dB	
Extinction Ratio	ER	4		6.5	dB	
Optical Return Loss Tolerance	TOL			20	dB	
Transmitter Reflectance	R_T			-12	dB	
Average Launch Power OFF Transmitter, each Lane	P_{off}			-30	dBm	

Receiver

Signaling Speed per Channel			27.95		Gbps	
Lane Wavelength	L0	1294.53	/	1296.59	nm	
	L1	1299.02	/	1301.09	nm	
	L2	1303.54	/	1305.63	nm	
	L3	1308.09	/	1310.19	nm	
Total Average Receive Power				10.5	dBm	
Average Receive Power, each Lane		-6.9		4	dBm	
Receiver Sensitivity , each Lane	SEN			-8.4	dBm	1
Total Average Launch Power	PIN			10	dBm	
Difference in Receive Power between any Two Lanes (OMA)	$P_{rx,diff}$			5.5	dB	
LOS Assert	LOS_A	-25			dBm	
LOS De-assert	LOS_D			-13	dBm	
LOS Hysteresis	LOS_H	0.5		6	dB	

Notes:

1. Specified at a BER of 10⁻⁶ (pre-FEC), per ITU-T G.sfp39.

V. Digital Diagnostic Functions

The following digital diagnostic characteristics are defined over the Recommended Operating Environment unless otherwise specified. It is compliant to SFF-8436.

Parameter	Symbol	Min	Max	Unit	Note
Temperature monitor absolute error	DMI_Temp	-3	3	° C	Over operating temperature range
Supply voltage monitor absolute error	DMI_VCC	-3%	+3%	V	Over full operating range
Channel RX power monitor absolute error	DMI_RX_Ch	-2	2	dB	
Channel Bias current monitor	DMI_Ibias_Ch	-10%	10%	mA	Ch1~Ch4
Channel TX power monitor absolute error	DMI_TX_Ch	-2	2	dB	

VI. Transceiver Block Diagram

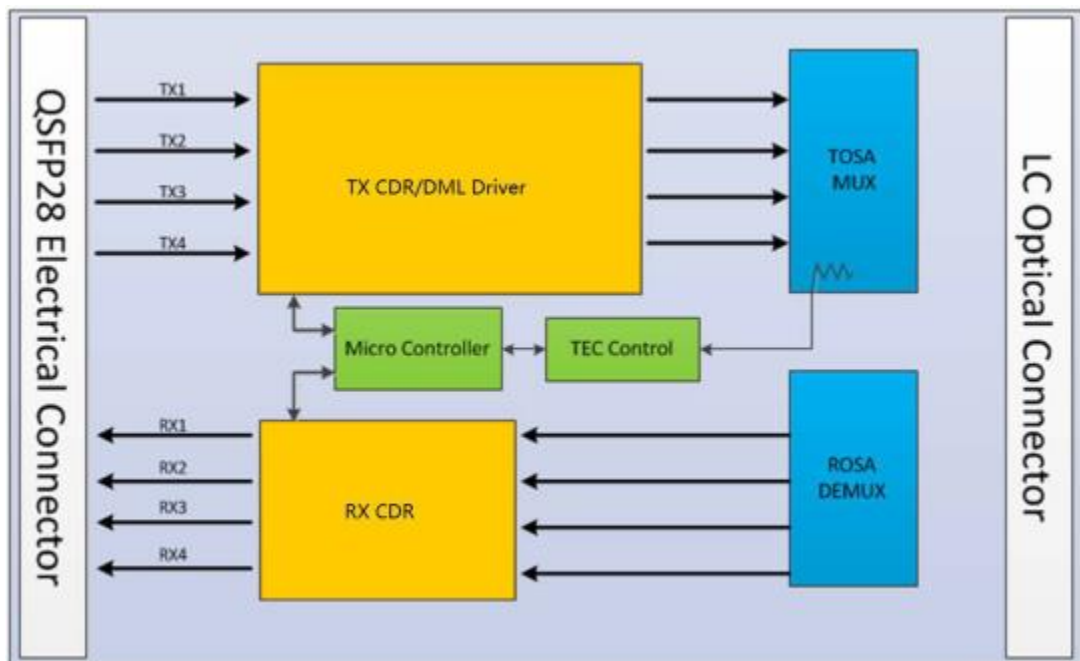

VII. PIN Assignment and Description

Pin	Logic	Symbol	Name/Description	Notes
1		GND	Ground	1
2	CML-I	Tx2n	Transmitter Inverted Data Input	
3	CML-I	Tx2p	Transmitter Non-Inverted Data output	
4		GND	Ground	1
5	CML-I	Tx4n	Transmitter Inverted Data Input	
6	CML-I	Tx4p	Transmitter Non-Inverted Data output	
7		GND	Ground	1
8	LVTTLL-I	ModSelL	Module Select	
9	LVTTLL-I	ResetL	Module Reset	
10		VccRx	+3.3V Power Supply Receiver	2
11	LVCNOS-I/O	SCL	2-Wire Serial Interface Clock	
12	LVCNOS-I/O	SDA	2-Wire Serial Interface Data	
13		GND	Ground	
14	CML-O	Rx3p	Receiver Non-Inverted Data Output	
15	CML-O	Rx3n	Receiver Inverted Data Output	
16		GND	Ground	1
17	CML-O	Rx1p	Receiver Non-Inverted Data Output	
18	CML-O	Rx1n	Receiver Inverted Data Output	
19		GND	Ground	1
20		GND	Ground	1
21	CML-O	Rx2n	Receiver Inverted Data Output	
22	CML-O	Rx2p	Receiver Non-Inverted Data Output	
23		GND	Ground	1
24	CML-O	Rx4n	Receiver Inverted Data Output	1

25	CML-O	Rx4p	Receiver Non-Inverted Data Output	
26		GND	Ground	1
27	LVTTL-O	ModPrsL	Module Present	
28	LVTTL-O	IntL	Interrupt	
29		VccTx	+3.3 V Power Supply transmitter	2
30		Vcc1	+3.3 V Power Supply	2
31	LVTTL-I	LPMode	Low Power Mode	
32		GND	Ground	1
33	CML-I	Tx3p	Transmitter Non-Inverted Data Input	
34	CML-I	Tx3n	Transmitter Inverted Data Output	
35		GND	Ground	1
36	CML-I	Tx1p	Transmitter Non-Inverted Data Input	
37	CML-I	Tx1n	Transmitter Inverted Data Output	
38		GND	Ground	1

Notes:

- 1.GND is the symbol for signal and supply (power) common for QSFP28 modules. All are common within the QSFP28 module and all module voltages are referenced to this potential unless otherwise noted. Connect these directly to the host board signal common ground plane.
- 2.VccRx, Vcc1 and VccTx are the receiver and transmitter power suppliers and shall be applied concurrently. Recommended host board power supply filtering is shown in Figure 4 below. Vcc Rx, Vcc1 and Vcc Tx may be internally connected within the QSFP28 transceiver module in any combination. The connector pins are each rated for a maximum current of 1000mA.

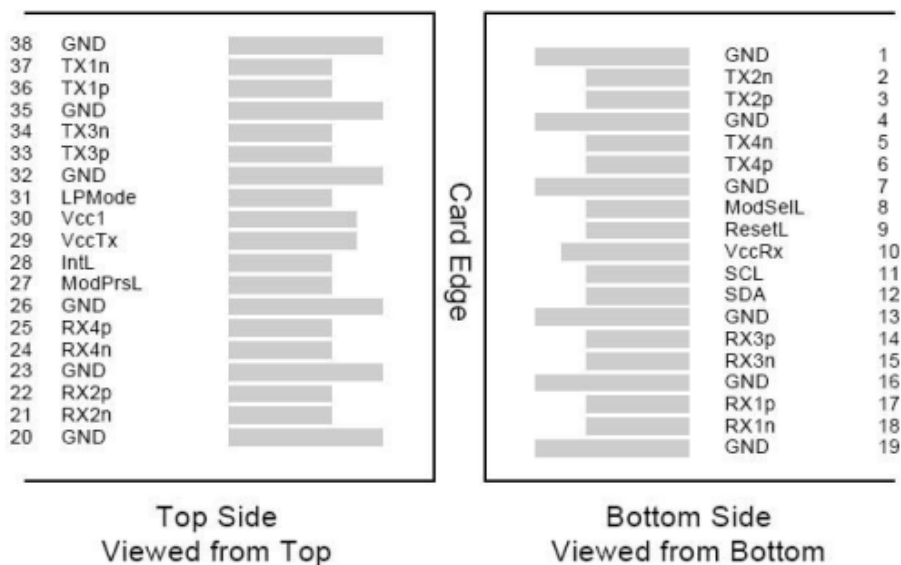

VIII. Recommended Power Supply Filter

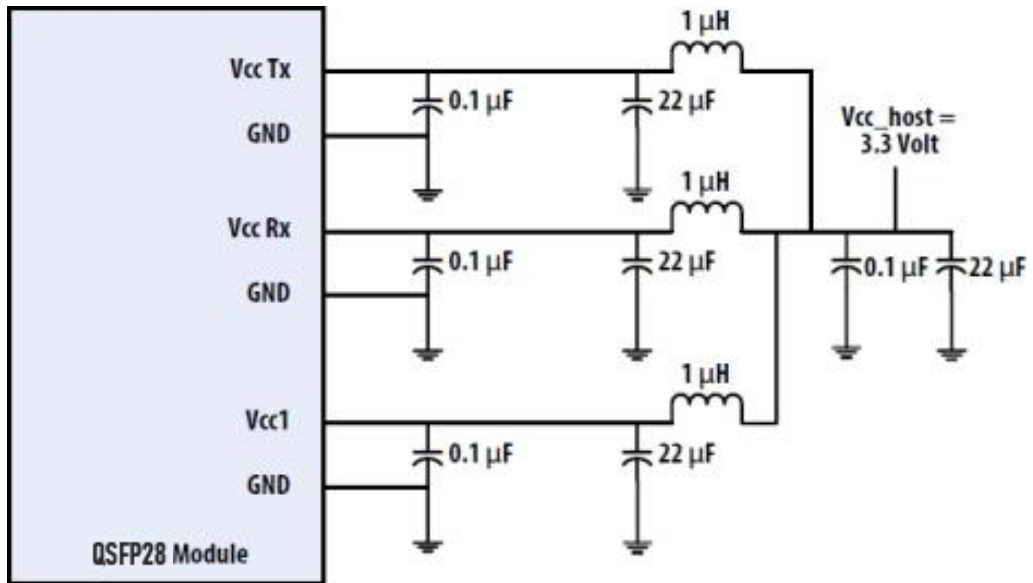

IX. Mechanical Dimensions

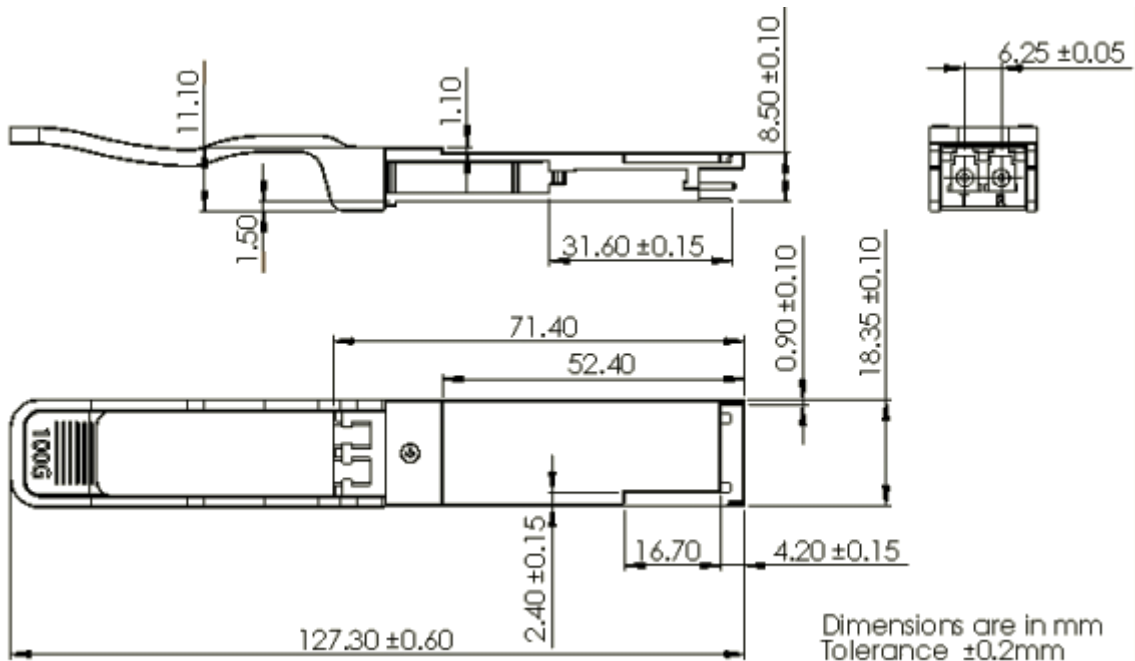

X. ESD

This transceiver is specified as ESD threshold 1KV for SFI pins and 2KV for all others electrical input pins, tested per MIL-STD-883, Method 3015.4 / JESD22-A114-A (HBM). However, normal ESD precautions are still required during the handling of this module. This transceiver is shipped in ESD protective packaging. It should be removed from the packaging and handled only in an ESD protected environment.

XI. Laser Safety

This is a Class 1 Laser Product according to IEC 60825-1:2007. This product complies with 21 CFR 1040.10 and 1040.11 except for deviations pursuant to Laser Notice No. 50, dated (June 24, 2007).

Test Center

FS.COM transceivers are tested to ensure connectivity and compatibility in our test center before shipped out. FS.COM test center is supported by a variety of mainstream original brand switches and groups of professional staff, helping our customers make the most efficient use of our products in their systems, network designs and deployments.

The original switches could be found nowhere but at FS.COM test center, eg: Juniper MX960 & EX 4300 series, Cisco Nexus 9396PX & Cisco ASR 9000 Series, HP 5900 Series & HP 5406R ZL2 V3(J9996A), Arista 7050S-64, Brocade ICX7750-26Q & ICX6610-48, Avaya VSP 7000 MDA 2, etc.



Cisco ASR 9000 Series(A9K-MPA-1X40GE)



ARISTA 7050S-64(DCS-7050S-64)

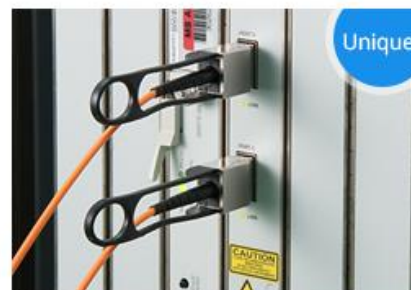

Juniper MX960



Brocade ICX 7750-26Q



Extreme Networks X670V VIM4-40G4X



Mellanox M3601Q



Dell N4032F



HP 5406R ZL2 V3(J9996A)



AVAYA 7024XLS(7002QQ-MDA)

Test Assured Program

FS.COM truly understands the value of compatibility and interoperability to each optics. Every module FS.COM provides must run through programming and an extensive series of platform diagnostic tests to prove its performance and compatibility. In our test center, we care of every detail from staff to facilities—professionally trained staff, advanced test facilities and comprehensive original-brand switches, to ensure our customers to receive the optics with superior quality.



Our smart data system allows effective product management and quality control according to the unique serial number, properly tracing the order, shipment and every part.

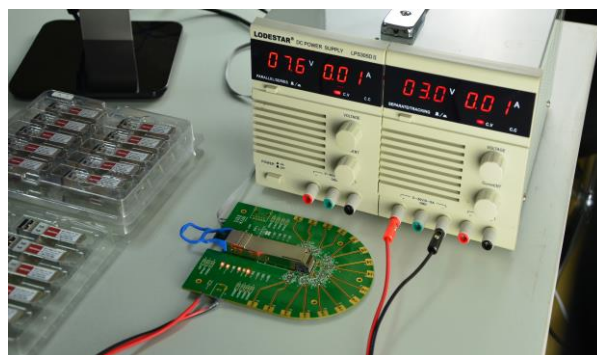

Our in-house coding facility programs all of our parts to standard OEM specs for compatibility on all major vendors and systems such as Cisco, Juniper, Brocade, HP, Dell, Arista and so on.



With a comprehensive line of original-brand switches, we can recreate an environment and test each optics in practical application to ensure quality and distance.



The last test assured step to ensure our products to be shipped with perfect package.

Order Information

Part Number	Description
QSFP28-SR4-100G	QSFP28 100GBASE-SR4 850nm 100m Transceiver
QSFP28-LR4-100G	QSFP28 100GBASE-LR4 1310nm 10km Transceiver
QSFP28-PIR4-100G	QSFP28 100GBASE-PSM4 1310nm 500m Transceiver
QSFP28-IR4-100G	QSFP28 100GBASE-CWDM4 1310nm 2km Transceiver
QSFP28-EIR4-100G	QSFP28 100GBASE-eCWDM4 1310nm 10km Transceiver
QSFP28-ER4-100G	QSFP28 100GBASE-ER4 1310nm 40km Transceiver
Q28-100/112G-10	QSFP28 100GBASE-LR4 and 112GBASE-OTU4 Dual Rate 1310nm 10km Transceiver
Q28-100/112G-20	QSFP28 100GBASE-LR4 and 112GBASE-OTU4 Dual Rate 1310nm 20km Transceiver
QSFP28-ER4-100G	QSFP28 100GBASE-ER4 and 112GBASE-OTU4 Dual Rate 1310nm 30km Transceiver
Q28-100/112G-40	QSFP28 100GBASE-ER4 and 112GBASE-OTU4 Dual Rate 1310nm 40km Transceiver

Notes:

1. 100G QSFP28 transceiver module is individually tested on corresponding equipment such as Cisco, Arista, Juniper, Dell, Brocade and other brands, and passes the monitoring of FS.COM intelligent quality control system.



 <https://www.fs.com>



The information in this document is subject to change without notice. FS has made all efforts to ensure the accuracy of the information, but all information in this document does not constitute any kind of warranty.